

High impedance differential relay 7VH80

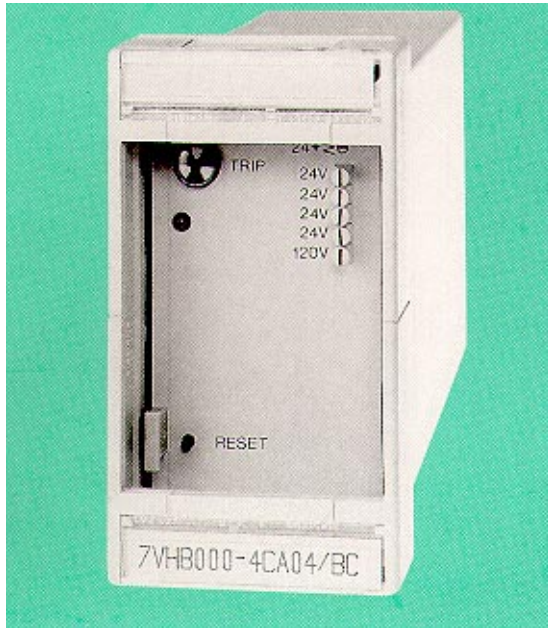

Fig 1. High impedance differential protection relay 7VH80

Features

- Robust solid state design.
- Inrush stabilization through filtering.
- Auxiliary dc supply monitor.
- Fast operating time (15ms).
- Voltage operated target indicator.
- Simple voltage setting.

Applications

The 7VH80 relay is designed for fast and selective differential protection based on the high impedance circulating current principle. It is used for the protection of machine stator windings, busbars and transformer and reactor windings against phase to phase and phase to earth short circuits.

Design

The withdrawable module is housed in a 7XP2010 metal case suitable for flush mounting. The plug connector at the rear of the case has one screw and one snap on terminal for each connection point. The plug connector is marked with a coordinated system depending on the mounting location e.g. 4A1 denoted row 4, block 1, column

1. The individual connections are marked sequentially from left to right (viewed from the rear). See fig. 3.

Mode of Operation

The 7VH80 relay is a single pole sensitive current relay. The AC input impedance of the relay is adjusted by means of a series of high wattage resistors. The relay setting is a voltage pick-up value that is set by means of connecting pins that are inserted in the front of the relay module. When the pin is inserted, the corresponding series resistor is shorted out and when the pin is withdrawn, the resistor is in circuit. Each pin socket has a voltage value. The relay voltage setting is determined by adding up the socket value all of the withdrawn pins (series resistors in circuit) plus the minimum base voltage setting. These series resistors are termed stabilizing resistors and the setting on the relay determines the steady state rms voltage required for relay operation.

The input from the CT's is connected to terminals 1A1 and 1A2. The relay input transformer galvanically isolates the relay

static measurement circuit from the main current transformers.

The AC measured current is band pass filtered and rectified to a proportional dc voltage. This voltage is monitored by a Schmidt trigger circuit. If the set dc voltage, equivalent to the relay nominal operating current of 20mA is exceeded, then the trigger operates to energise the command output relay as well as the operation indicator.

The auxiliary dc supply is connected to terminals 4A1(+ve) and 4A2(-ve). An auxiliary dc supply monitoring circuit consisting of a green LED and a N/C relay contact is provided to indicate the status of the dc supply.

The relatively simple electronic design of the 7VH80 provides a robust and reliable relay suitable for all high impedance circulating current protection applications.

The employ of a solid state measurement circuit ensures a relatively constant and fast operating time.

See fig. 2 for the connection diagram.

High impedance differential relay 7VH80

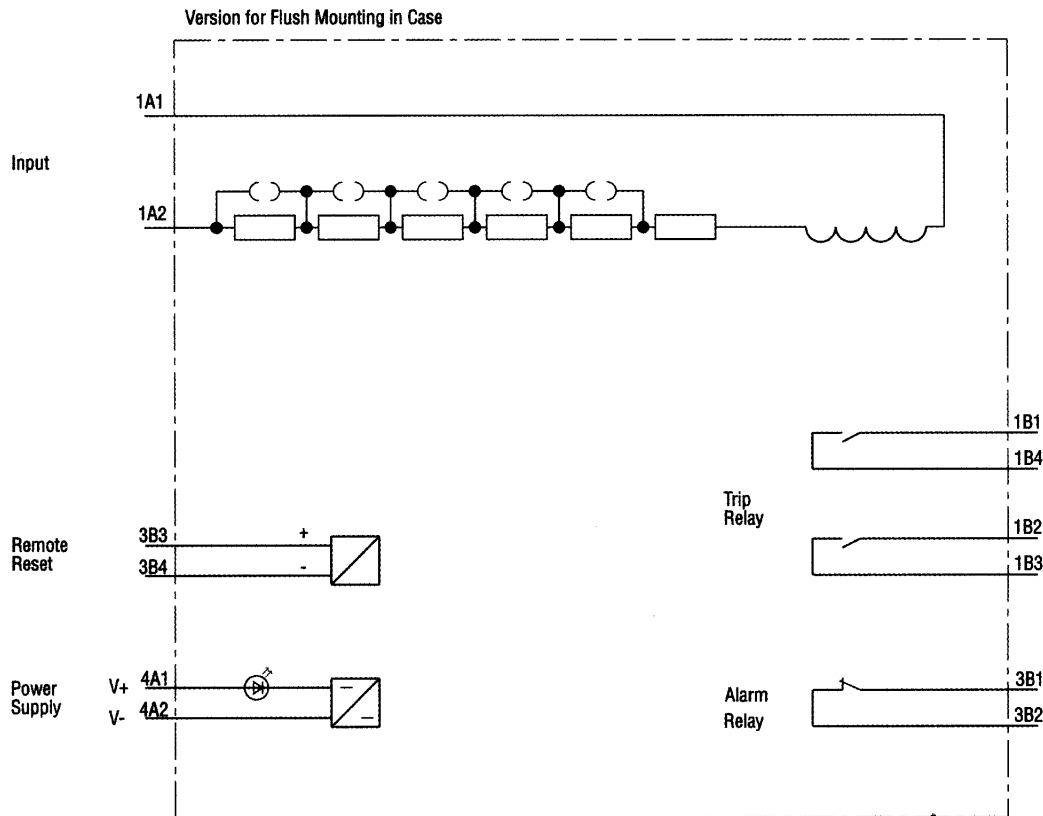

Fig 2. Connection diagram for 7VH80 relay

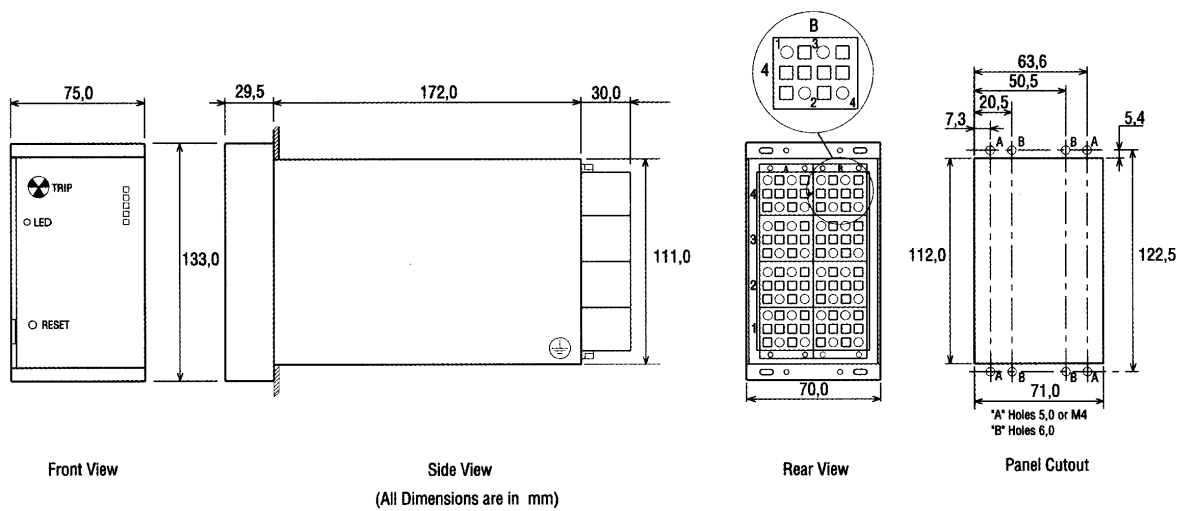

Fig 3. 7VH80 relay in flush mount case

High impedance differential relay 7VH80

Technical Data

CT Circuits		
Normal Frequency	50 Hz or 60 Hz	
Thermal Withstand		
1 sec	5 x setting (volts)	
Continuous	2 x setting (volts)	
Measuring Circuit		
Setting Range:		
24 Volt version	24+24+24+24+24+120	Max 240 Volt
6 Volt version	6+6+6+6+6+30	Max 60 Volt
Tripping Time		
2 x setting	30 ms	
3 x setting	20 ms	
5 x setting	13 ms	
Pick up to drop out ratio	0.95	
Reset Time	20 ms	
Supply and Reset voltages		
	24V dc	± 20%
	30V dc	± 20%
	48V dc	± 20%
	110/125V dc	± 20%
	220V dc	± 20%
Supply Burden (at rated voltage)		
For all voltages		
Quiescent	4 W	
Picked up	5 W	
Contacts		
	Command Output	Alarm
Number of Contacts	2 N/O	1 N/C
Make	1 000 W/VA	30W/VA
Break	30W/VA	30W/VA
Carry	30A for 0,5s and 5A continuous	
Max. Switching Voltage	250V AC/dc	
Indication	1 off voltage operated target indicator	
Environmental Withstand		
Max. Temperatures, during		
Service	- 10°C to + 55°C	
Storage	- 25°C to + 55°C	
Transport	- 25°C to + 70°C	
Humidity, acc. to DIN 40 040	class F	

High impedance differential relay 7VH80

Vibration, service	0.5g between 60 to 500 Hz 0.035 mm amplitude between 10 to 60 Hz
Vibration, transport	2 g between 8 to 500 Hz 7,5 mm amplitude between 5 to 8 Hz
Insulation Tests HV Test IEC 255-5 Impulse Test IEC 255-5	2kV (rms)., 50/60 Hz; 1 min 5kV (peak); 1,2/50 μ s; 0,5J; sec 3 positive and 3 negative shots at intervals of 5s
High Frequency Test IEC 255-22-1 Class III	2,5 kV (peak); 1 MHz; $\pi = 1,5 \mu$ s; 400 shots/s duration 2s
EMI Test IEC 801-3 ANSI/IEEE C37.90.2	 20 MHz to 1000 MHz at 10V/m field strength
Weight Dimensions Withdrawable Module	 3U; 12 slots of 5.08 mm
Case Standard metal case for flush mounting Size Extra frame for surface mounting Enclosure protection Mass	 7XP2010-2C 1/6 of 19" rack 7XP21 IP51 Approx. 1kg
Modular Terminal Block Each terminal provides one snap-on connection one tunnel type screw connection	 1.5 mm ² wire

High impedance differential relay 7VH80

Ordering Data

	Order No.					
High impedance differential relay	7VH80		-		C	A
Supply Frequency						
50 Hz	0					
60 Hz	1					
Voltage Range						
24V Steps with Flag		0				
6V Steps with Flag		1				
Auxiliary Supply Voltage (Not Isolated)						
24V dc				1		
30V dc				2		
48V dc				3		
110/125V dc				4		
220V dc				5		
Case Option						
Module in Case					C	
With Varistor						0
Without Varistor						1
Reset Voltage						
24V dc						1
30V dc						2
48V dc						3
110/125V dc						4
220V dc						5

ORDERING DATA

Please specify the varistor type required for your application or consult your nearest Siemens office.

High impedance differential relay 7VH80

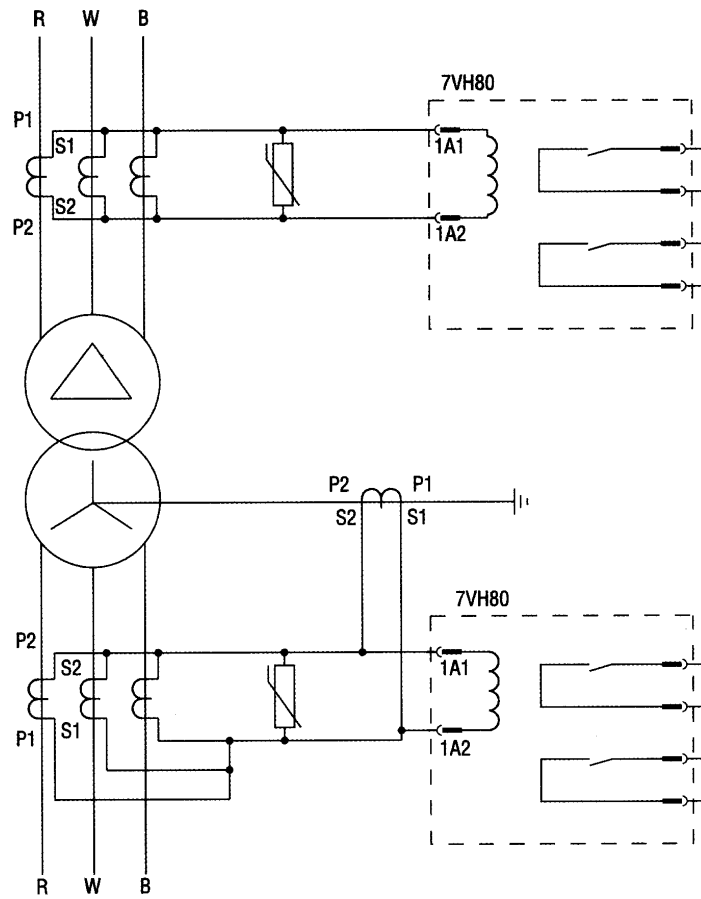

Fig 4. Restricted earth fault protection of power transformer windings

High impedance differential relay 7VH80

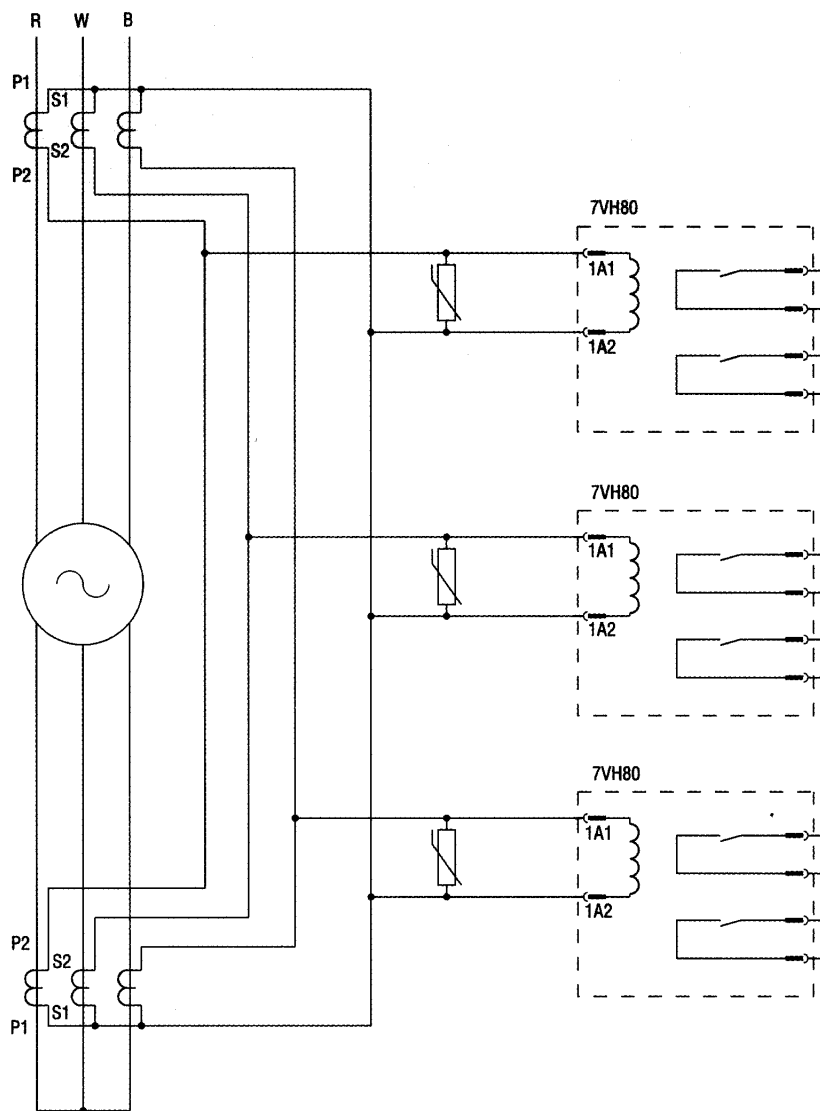

Fig 5. Phase and earth fault protection of a generator

Relay setting

High impedance differential relay 7VH80

List of abbreviations

- I_E** = Current transformer exciting current at relay setting voltage.
(referred to the CT secondary current)
- I_F** = Maximum value of primary through fault current for which protection must remain stable.
- I_{FM}** = Maximum value of primary fault current for internal fault.
- I_p** = Primary current for operation of protection.
- I_R** = Relay operating current.
- I_{SH}** = Current in shunt resistor at relay setting V_R.
- N** = Turns ratio of current transformer.
- n** = No. of current transformers in parallel with relay.
- R_{CT}** = Secondary resistance of current transformer.
- R_L** = Lead resistance between furthest current transformer and relay connection point.
- R_R** = Relay impedance.
- R_{SH}** = Value of shunt resistor.
- V_F** = The theoretical voltage which would be produced across the relay circuit under internal fault conditions.
$$V_F \geq \frac{I_{FM}}{N} (R_{CT} + 2R_L + R_R)$$
- V_K** = Knee point voltage of current transformer.
- V_P** = Peak voltage across relay circuit under maximum internal fault conditions.
- V_S** = Minimum Setting voltage. (Calculated)
- V_R** = Relay setting voltage.
- K** = Varistor constant.
- B** = Varistor constant.

High impedance differential relay 7VH80

Calculation of relay setting

The minimum setting voltage to ensure stability is

$$V_s \geq \frac{I_{FM}}{N} (R_{CT} + 2R_L)$$

The relay plug setting voltage V_R must be set to the nearest tap above V_s . The minimum knee

point voltage must be $V_K \geq 2V_R$. The operating current of the relay is 20mA irrespective of the voltage selected excluding the current drawn by the external varistor. When a standard varistor is included with the relay, the relay operating current

including the varistor is given in the table below (Fig 1.). It must be appreciated that varistors have large tolerances and these figures are given for guidance only.

Setting Voltage V_R in volts	24	48	72	96	120	144	168	192	216	240
Relay current I_R (including varistor) in mA	20	20	20	22	22	23	25	26	28	30

Table 1

The primary current for operation is given by

$$I_P = N (I_R + nI_E)$$

If the resultant value of I_P is too low it may be increased by the addition of a shunt resistor R_{SH} to give a current of

$$I_{SH} = V_R / R_{SH}$$

The new increased value of primary current

$$I_P = N (I_R + nI_E + I_{SH})$$

Setting advice

With particular reference to high impedance busbar protection, the plant and equipment should have protection with the following features:

- adequate sensitivity
- fast response time
- stability, when external faults occur
- selectivity to allow disconnection of only the faulted section
- permanent supervision of the current transformers (optional)

Relay operation shall not occur on:

- saturation of the CT's by the transient dc component when a serious fault occurs outside the zone
- accidental open or short circuit of the secondary of one or more CT's

Two types of configuration are generally provided:

- single phase faults; requiring one 7VH80 relay
- polyphase faults; requiring a grouping of three (3) 7VH80 relays

Current transformer supervision, if called for, protects against the accidental opening of a CT connection. This occurrence normally causes a fault current that is too low to activate the relay circuits, however the condition should be signalled before the appearance of an actual fault. The supervision would register the low unbalanced current and control a time delayed output alarm.

Knee-point voltage of current transformers

The CT's will not be saturated by the short-circuit current if the knee-point voltage is greater than twice the maximum voltage likely to be applied across the terminals of the relay during the fault.

$$V_{RMAX} = 2\sqrt{2V_K(V_F - V_K)}$$

At the maximum secondary through fault current the varistor should limit the voltage to 1 500V rms if possible.

Determination of magnetizing current I_E

The manufacturer of the current transformer supplies the magnetic characteristics

from which the magnetizing current curve versus the secondary voltage is shown. From this curve, it is easy to determine the magnetizing current I_E for a secondary voltage of V .

CT supervision circuit

If the CT's have broken or shorted connections, the protective relay may detect this condition as a busbar fault and therefore trip all the circuit breakers in that zone. If several CT's are associated in the zone, the disconnection of one of them (corresponding perhaps to a lightly loaded feeder) will result in a very low fault current measurement. If this unbalance is lower than the 7VH80 setting, this condition will not be detected. Therefore a more sensitive monitoring circuit is required for CT supervision.

This supervision circuit operates with a time delay to avoid a false alarm signal in case of a busbar fault. When choosing a setting the following rule should generally be adopted:

The supervision relay must be sensitive to an unbalance corresponding to a busbar current of 25A or to 10% of the current in the least loaded ingoing or outgoing feeder. The highest current value will be adopted. Further details may be provided on request.

High impedance differential relay 7VH80

Amendment 1 to page 10 of 7VH80 Publication G 53300-Y33-U19-1-18

Varistor Selection

Each 7VH80 relay is normally applied with an external varistor which must be connected across the relay input terminals. The varistor limits the voltage developed across the CT and relay terminals under fault conditions.

A varistor is a non-linear or voltage dependent resistor. It is a ceramic semi-conducting resistance material in which the

relationship between resistance and applied voltage is non-linear, i.e. an increase in the applied voltage will result in a decrease in the resistance and hence an increase in the current. The change in resistance occurs instantaneously.

The electrical characteristics can be expressed as $V = KI^B$ where K and B are constant for any one varistor.

If the current transformer secondary voltage is to be limited to a safe level during maximum internal fault conditions then a varistor may be required. Generally if $V_{RMAX} > 2KV$ then a varistor is required

$$V_{RMAX} = 2\sqrt{2V_K(V_F - V_K)}$$

Relay Voltage Setting	K	B	Varistor type
Up to 125V rms	450	0.25	600A/S1/S256
125 - 240 rms	900	0.25	600A/S1/S1088

Table 2

K Characteristic	Max.Continuous Rating - rms	
450	200V	
900	350V	
Varistor Assembly Type	Unit K Value	Short Time Rating
Standard 600A/S1/S256	450	22A for 3 seconds 30A for 2 seconds 45A for 1 second
Standard 600A/S1/S1088	900	17A for 3 seconds 30A for 1.5 seconds 39A for 1 second

Table 3

Installation and Commissioning Instructions

Installation

Protective relays, although generally of robust construction, require careful treatment prior to installation. By observing a few simple rules the possibility of premature failure is eliminated and a high degree of performance can be expected.

The relays are either despatched individually or as part of a panel/rack mounted assembly in cartons specifically designed to protect them from damage. Relays should be examined immediately they are received to ensure that no damage has been

sustained in transit. If damage due to rough handling is evident, a claim should be made to the Transport Company concerned immediately and the nearest Siemens Office should be promptly notified. Relays which are supplied unmounted and not

High impedance differential relay 7VH80

intended for immediate installation should be returned to their protective cartons.

Care must be taken when unpacking and installing the relays so that none of the parts are damaged or their settings altered and must at all times be handled by skilled persons only.

Relays which have been removed from their cases should not be left in situations where they are exposed to dust or damp. This particularly applies to installations which are being carried out at the same time as construction work.

If relays are not installed immediately upon receipt they should be stored in a place free from dust and moisture in their original cartons and where dehumidifier bags have been included in the packing they should be retained.

The action of the dehumidifier crystals will be impaired if the bag has been exposed to damp ambient conditions and may be restored by gently heating the bag for about an hour, prior to replacing it in the carton.

Dust which collects on a carton may, on subsequent unpacking, find its way into the relay; in damp conditions the carton and packing may become impregnated with moisture and the de-humidifying agent will lose its efficiency. The storage temperature range is -25° and +55°C.

The installation should be clean, dry and reasonably free from dust and excessive vibration. The site should preferably be well illuminated to facilitate inspection. The relay should be mounted in the cut-out or rack provided (Fig 3.) and wired according to Figure 2 or the relevant drawing or schematic diagram.

Commissioning preliminaries

Inspection

Carefully examine the module and case to see that no damage has occurred during transit. Check that the relay serial number on the module, case and cover are identical, and that the model number and rating information are correct.

Check that the external wiring is correct to the relevant relay diagram or scheme diagram.

Particular attention should be paid to the correct wiring and value of any external resistors indicated on the wiring diagram/relay rating information.

Note that shorting switches shown on the relay diagram are fitted internally across the relevant case terminals and close when the module is withdrawn. It is essential that such switches are fitted across all CT circuits.

If a test block is provided, the connections should be checked to the scheme diagram, particularly that the supply connections are to the 'live' side of the test block.

Earthing

Ensure that the case earthing connection at the rear terminal block, is used to connect the relay to a local earth bar.

Insulation

The relay, and its associated wiring, should be insulation tested between:

- all electrically isolated circuits
- all circuits and earth

An electronic or brushless insulation tester should be used, having a dc voltage not exceeding 1000V. Accessible terminals of the same circuit should first be strapped together. Deliberate circuit earthing links, removed for the

tests, must subsequently be replaced.

It is only necessary to check the relay at the setting on which it is to be used. The relay must not be used at any setting other than that for which the setting has been calculated.

Commissioning Tests Test Equipment

- 1 Secondary injection test equipment capable of providing an AC voltage supply of up to at least 120% of the relay setting.
- 1 Test plug for use with test block if fitted.
- 3 Calibrated multimeters 0-10 amp AC 0 - 400 volt AC.
- 1 Set of primary injection testing equipment

General

If the relay is wired through a test block it is recommended that all secondary injection tests should be carried out using this block.

Ensure that the main system current transformers are shorted before isolating the relay from the current transformers in preparation for secondary injection tests.

Danger

Do not open circuit the secondary circuit of a current transformer since the high voltage produced may be lethal and could damage insulation.

Secondary injection testing

Connect the circuit as shown in Figure 6 and ensure that the current transformer primary is open circuit and that if any earthing connections are fitted, they do not short out the primaries of any current transformers.

Increase the voltage until the relay just operates.

High impedance differential relay 7VH80

Record the current at which the relay operates (A2). It should be approximately 20mA at setting.

Note also the voltage at which the relay operates which should correspond to the setting V_R of the relay with a tolerance of $\pm 10\%$. The total secondary current for operation will be given on ammeter A1. This test should be repeated for each pole of the relay.

Record the value at which the relay picks up and then reduce the voltage until it drops off. From these two values calculate the drop off/pick up value. It should be approximately 0,95.

Primary injection testing

It is essential that primary injection testing is carried out to prove the correct polarity of current transformers.

Before commencing any primary injection testing it is essential to ensure that the circuit is dead, isolated from the remainder of the system and that only those earth connections associated with the primary test equipment are in position.

Primary fault setting

The primary fault setting of any balanced scheme can be checked using the circuit shown in Figure 7. The primary current is injected into each current transformer in turn and increased until the relay

operates. The voltage at which the relay operates should be within $\pm 10\%$ of the relay setting voltage V_R . The primary current for operation and relay current should be noted.

In the case of machine protection similar tests must be carried out by injecting first into each current transformer in turn to determine the primary fault setting.

For large machines the machine itself can be used to provide the fault current to check the primary fault setting as shown in Figure 10. The machine should be run up to speed with no excitation. The excitation should then be increased until the relays have all operated. The primary current, relay current and relay voltage should be noted as each relay operates.

Through fault stability

With any form of unbalanced protection it is necessary to check that the current transformers are correctly connected. For this purpose with a restricted earth fault scheme the circuit shown in Figure 6 may be used. During this test the relay is shorted out and the spill current through the relay circuit A2 is measured. The current is increased up to as near full load as possible and the spill current noted. The spill current should be very low, only a few milliamps if the

connections are correct. A high reading (twice the injected current, referred through the current transformer ratio) indicates that one of the current transformers polarity is reversed.

Injection should be carried out through each phase to neutral.

Where primary injection is not practicable as in the case of restricted earth fault protection on a transformer it may be possible to check stability by means of back energising the transformer from a low voltage supply as shown in Figure 9. (eg. 380V)

In the case of machine protection similar stability tests must be carried out by injecting into one and out of another current transformer connected on the same phase.

For large machines, the machine itself can be used to provide the fault current, but the short circuit must now be fitted as shown in Figure 11. The machine should be run up to normal speed and the excitation increased until the primary current is approximately full load, when the spill current should be checked.

All other types of balanced protection should be tested in a similar manner.

At the conclusion of the tests ensure that all connections are correctly restored and any shorting connections removed.

ADDENDUM		COMMISSIONING TEST RECORD		DATE	<input type="text"/>
HIGH STABILITY					
CIRCULATING CURRENT RELAY					
TYPE 7VH80					
STATION	<input type="text"/>	CIRCUIT	<input type="text"/>		
RELAY MODEL NO.	<input type="text"/>	SERIAL NO.	<input type="text"/>		
SETTING RANGE	<input type="text"/>	CT RATIO	<input type="text"/>		
SETTING VOLTAGE	<input type="text"/>	RELAY SETTING	<input type="text"/>		
		SHUNT RES.	<input type="text"/>		
		OHMS (if fitted)			
TYPE OF EXT.	<input type="text"/>	CALCULATED PRI.	<input type="text"/>		
VARISTOR		OP CURRENT			

High impedance differential relay 7VH80

High impedance differential relay 7VH80

TEST RESULTS

Relay CT Shorting Switch

Secondary Voltage to operate relay

Phase	Total Current (A1)	Relay Current (A2)	P.U. Volts	D.O. Volts
A				
B				
C				

Drop off / Pick up ratio check

Table 5

Primary Current to operate relay

Phase	Primary Current A1	Relay Current A2	Relay Voltage
A			
B			
C			
N			

Table 6

Stability check by primary injection

Restricted Earth Fault

Phases A1	Primary Current A2	Spill Current
A - N		
B - N		
C - N		

Table 7

Circulating Current between two or more sets of current transformers

Phases A1	Primary Current A2	Spill Current
A1 - A2		
B1 - B2		
C1 - C2		

Table 8

Where more than two sets of current transformers are involved, injection should be carried out between set 1 and each other set in turn.

Maintenance

Periodic maintenance is not necessary. However, periodic inspection and test is recommended. This should be carried out every 12 months or more often if the relay is operated frequently or is

mounted in poor environmental conditions.
Repeat secondary injection tests to prove correct operation, making sure the circuit breaker trips when the relay operates.

High impedance differential relay 7VH80

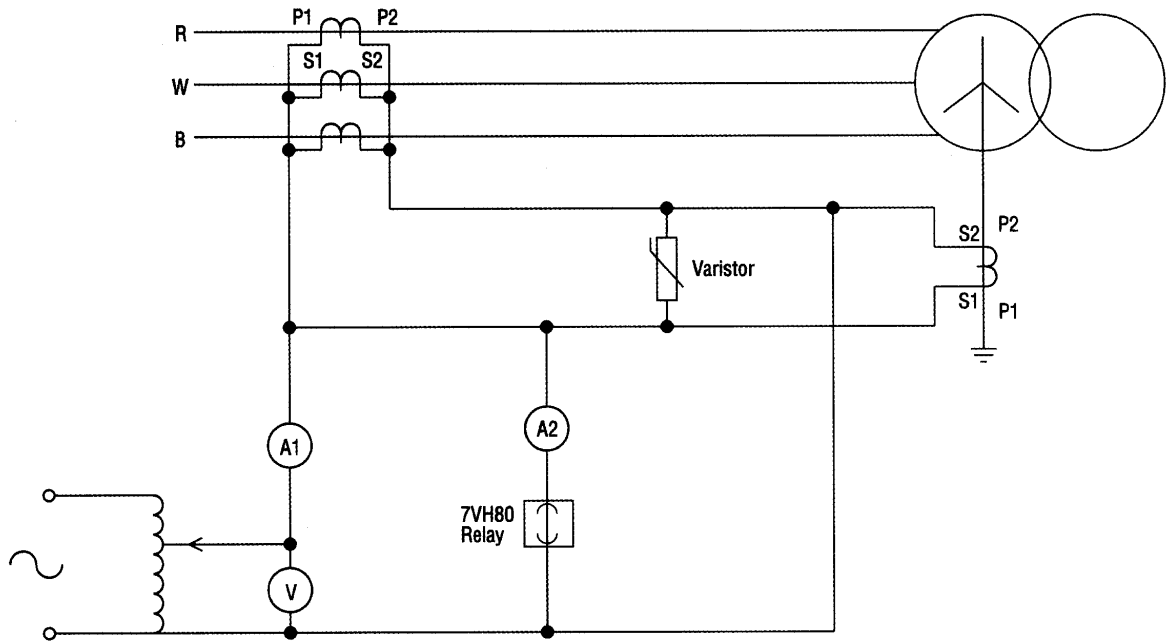

Fig 6. Secondary injection test

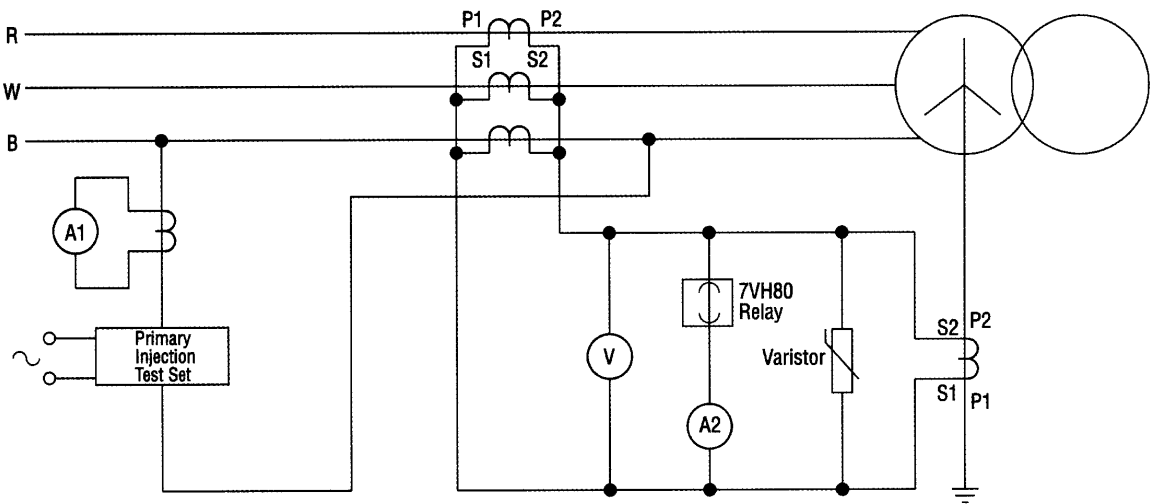

Fig 7. Primary fault setting test

High impedance differential relay 7VH80

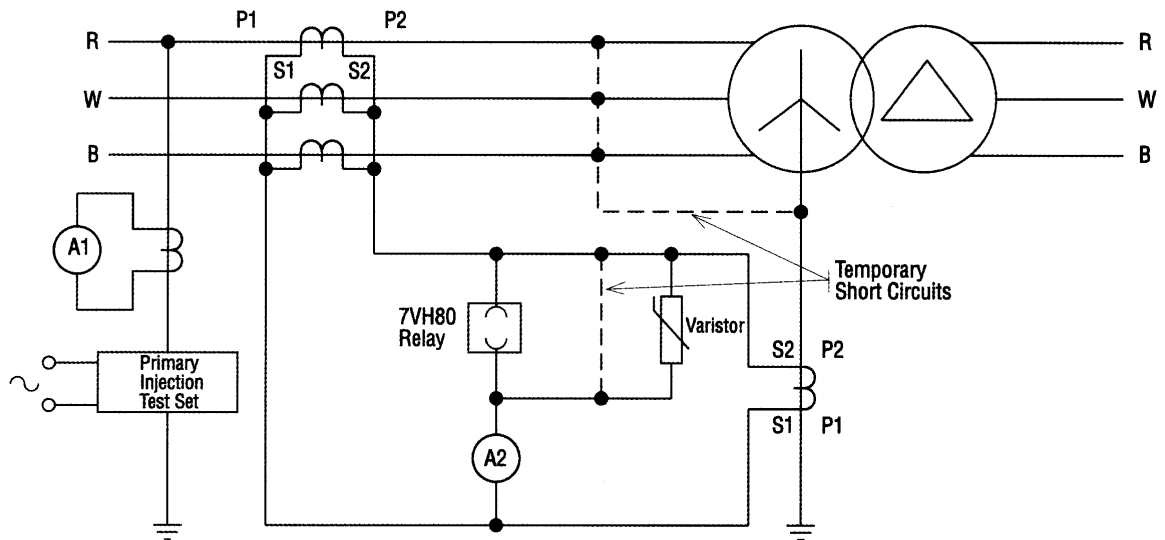

Fig 8. Through fault stability test

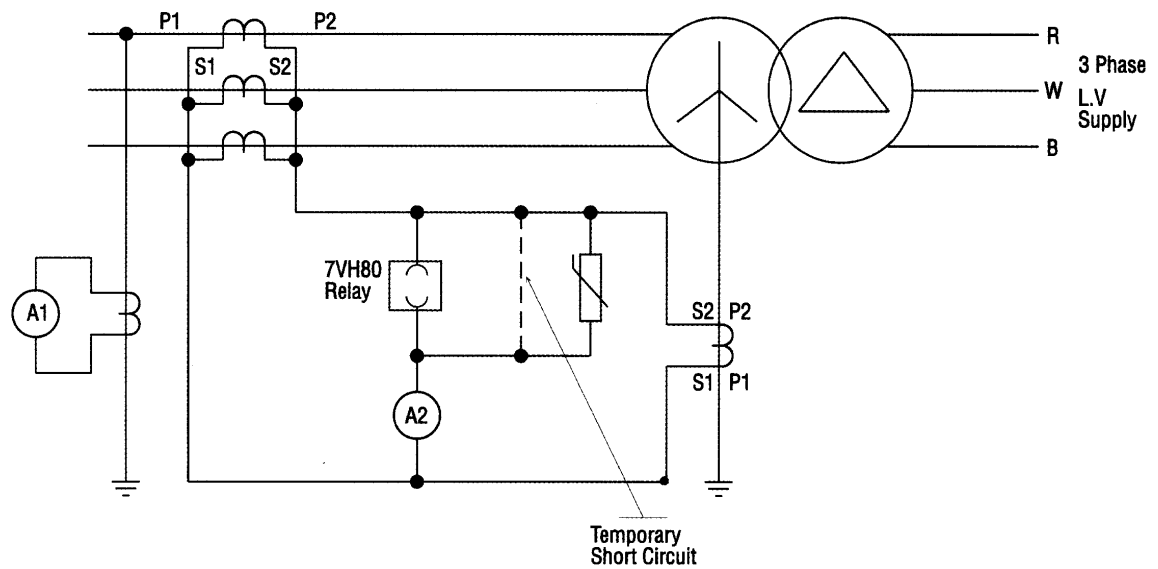

Fig 9. Through fault stability test

High impedance differential relay 7VH80

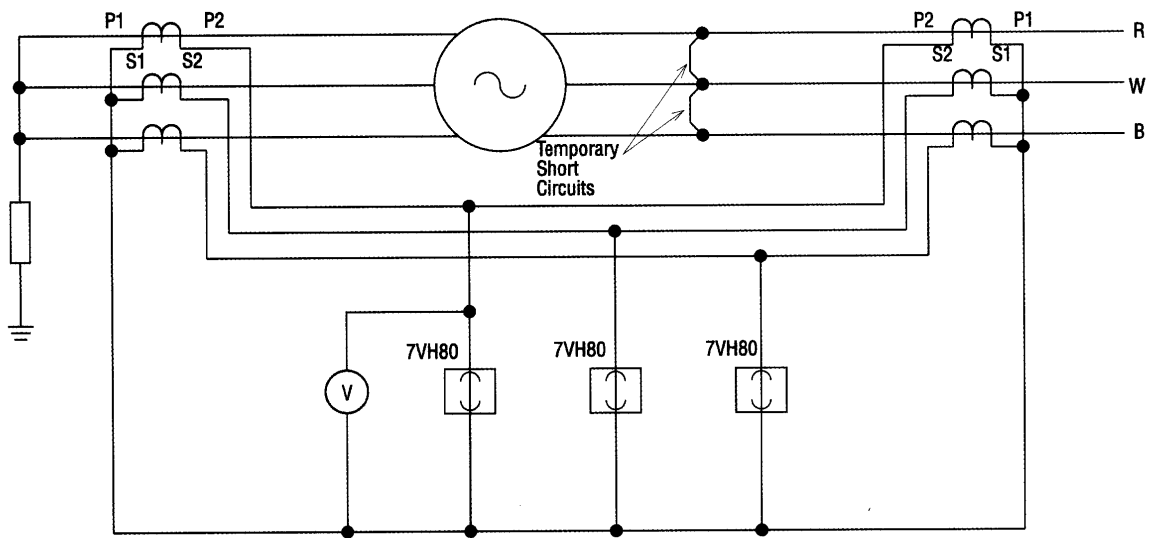

Fig 10. Primary fault setting test

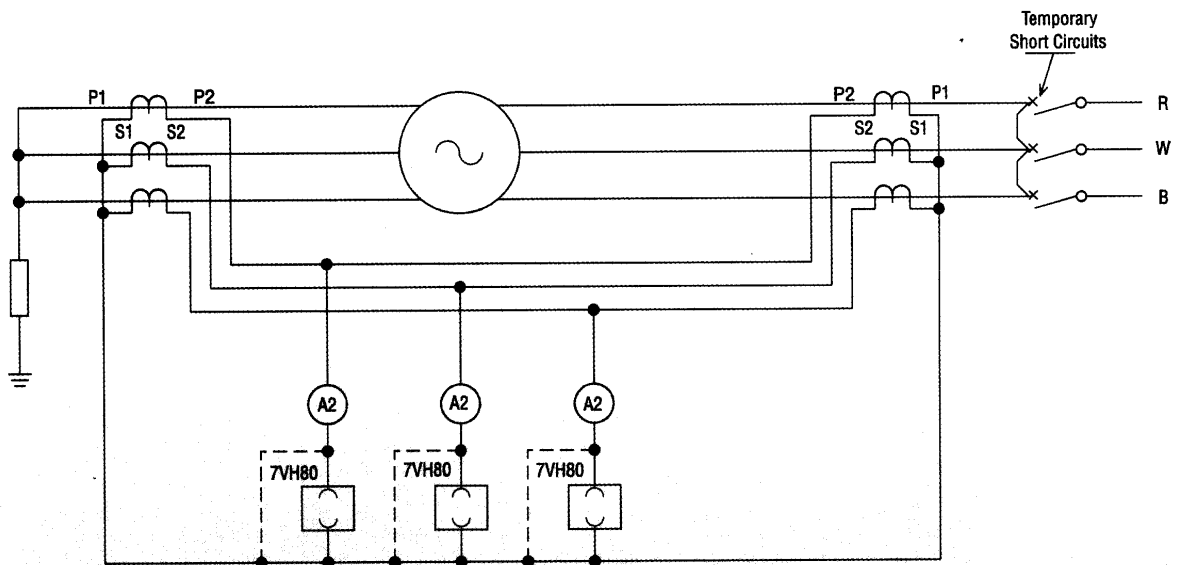

Fig 11. Through fault stability test

The information contained in this publication is subject to change without prior notice.

Siemens Limited
 P O Box 207 Isando 1600
 South Africa
 Telephone (011) 921-7000

Issued by Energy and Automation Group - Power Transmission and Distribution