



**Fig. 13/18** 7XV5673 SICAM I/O-Unit – binary I/O mirror, -binary I/O expansion, -contact multiplier

### Description

SICAM I/O-Unit 7XV5673 is a binary input/output device and is designed for substations and increased industrial environment requirements. The SICAM I/O-Unit allows the transmission of binary inputs to binary outputs locally or via long distances. It can be used for protection applications, e.g. overcurrent protection, signal comparison, teleprotection or as I/O-expansion in substation automation systems.

### Function

Via binary inputs, all kinds of binary signals of switchgear/ protection scheme (for example tripping commands, switch position signal, fault and status indications) are securely detected. This information can directly be distributed at this SICAM I/O-Unit via contacts, or be transmitted via communication links to further SICAM I/O-Units or to automation systems.

Secured telegrams are used for the communication via Ethernet or serial connections. The parameter setting of the SICAM I/O-Unit is simply carried out with a standard Web browser at the PC which is connected by the Ethernet interface.

The SICAM I/O-Unit can be set as:

- I/O mirror: Point-to-point transfer of binary signals between two SICAM I/O-Units via Ethernet or a serial connection. Signal inputs and outputs assignable by the user.
- I/O expansion:
  - Expansion of substation controllers by binary inputs and outputs using standard protocols.
  - Detection and output of binary states by substation controllers via standard protocols Modbus RTU, Modbus TCP or IEC 61850.
  - Extension for protection devices of the compact class 7SJ80 and 7SK80 via connection on their low-cost Ethernet interface (LEM).
- Contact multiplier: Distribution of signals on one or several binary inputs via relay contacts of the same SICAM I/O-Unit, e.g. for isolation between different voltage levels.

### Function overview

- Binary inputs
  - 6 ruggedized EMC – hardened binary inputs
  - Pickup voltage threshold settable to DC 19 V, DC 88 V or DC 176 V for different station battery voltages
- Binary outputs
  - 6 command relay outputs
  - Safe state of contacts after loss of connection settable by the user
- Signal/Alarm outputs
  - 4 LED
- Wide-range power supply
  - 24 – DC 250 V  $\pm$  20 % and AC 100 – 230 V 45 – 65 Hz
- Electrical RJ45 Ethernet interface
  - Cascading many devices without additional costs by the use of the integrated switch
- Serial fiber-optic interface (optional)
  - ST-connector, 820 nm for multi-mode fiber 62.5/125  $\mu$ m, typical range 2000 m using fiber 62.5  $\mu$ m/125  $\mu$ m, baud rate 1.2 kBit/s – 187.5 kBit/s settable per software
- Serial RS485-interface (optional)
  - Sub-D plug, 9-pole female
- Protocols, communication
  - MODBUS TCP or MODBUS RTU for connection to a substation controller
  - MODBUS UDP for point-to-point connections between two SICAM I/O-Units
  - SNTP for time synchronization
  - IEC 61850 (GOOSE, MMS, Reporting)
- Housing
  - IP20 rail mounting
- Standards
  - CE, UL, IEC 60255, IEEE 61000 ...
- Environmental conditions
  - EMC hardened binary I/O for substation environment
  - Extended high temperature range up to 85 °C (16 h/day).

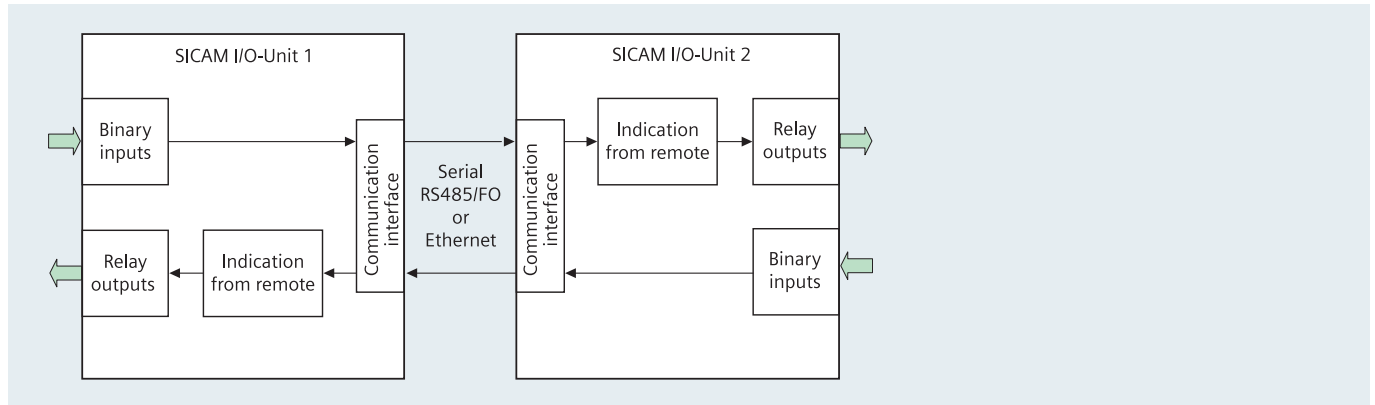

Fig. 13/19 I/O mirror, bi-directional transmission between two devices

### Operation features

- Easy parameterization with a standard Internet browser (no special software required)
- Password protection against unauthorized access
- Monitoring of data errors, loss of connection, transfer time and the state of BI, BO.
- Time synchronization with SNTP-Protocol with 1 ms resolution from an external time server over Ethernet. Redundant time servers are supported
- Buffer battery changeable from the front
- Fast I/O mirror: Fast transmission time from BI pickup to contact closing between two SICAM I/O-Units typically 11 ms for high bandwidth connection
- Connection to a substation controller over MODBUS TCP, MODBUS RTU or IEC 61850 (GOOSE, MMS, Reporting) protocol
- Blocking of data transmission with a binary input for testing
- Battery buffered operational event log with 1 ms resolution time stamp
- Assignment of BI/BO signals which shall be logged into the operational buffer
- Integration into network management systems with SNMP – protocol and provided MIB – files.

### Application

#### I/O mirror function

When using the SICAM I/O-Units as I/O mirror according to Fig. 13/19, the devices transmit the binary signals bi-directional. The transmission takes place between the two devices over serial links (option) or over Ethernet networks.

Via the relay output contacts voltages up to AC/DC 250 V and currents up to AC/DC 5 A can be switched. The pick threshold of the binary inputs can be set by the user on different levels.

Signal inputs and outputs can be assigned by the user.

#### Extension of the transmission distance

An extension of the transmission distance is possible. The following devices can be used:

- With serial optical repeater 7XV5461 scalable up to 170 km
- RS485-FO Converter 7XV5650 for cascading devices
- With different communication converters.

### Uni-directional binary signal transmission

When using the SICAM I/O-Units for uni-directional binary signal transmission according to Fig. 13/20, the devices transfer binary signals unidirectional from one device to several devices. In this application, the transmission only takes place in one direction. Input signals (max. 6) from the left unit are sending to output contacts of one or more units on the right side.

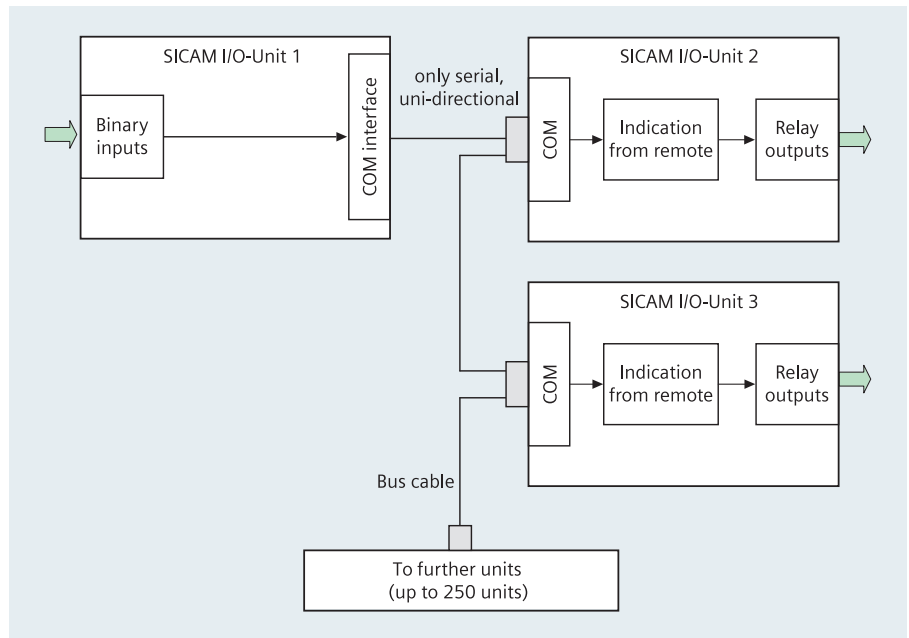

Fig. 13/20 I/O mirror, uni-directional transmission from one to multiple SICAM I/O-Units

### I/O expansion of a substation

The SICAM I/O-Unit is used as I/O expansion, according to Fig. 13/21. Binary signals are exchanged between a substation controller (e.g. SICAM PAS) and the SICAM I/O-Units by using the MODBUS TCP protocol over an Ethernet network. If the integrated switch in the SICAM I/O-Unit is used, the units can be operated in a line without using additional external switches as shown in Fig. 13/24. Also IEC 61850 client server communication will be provided in future.

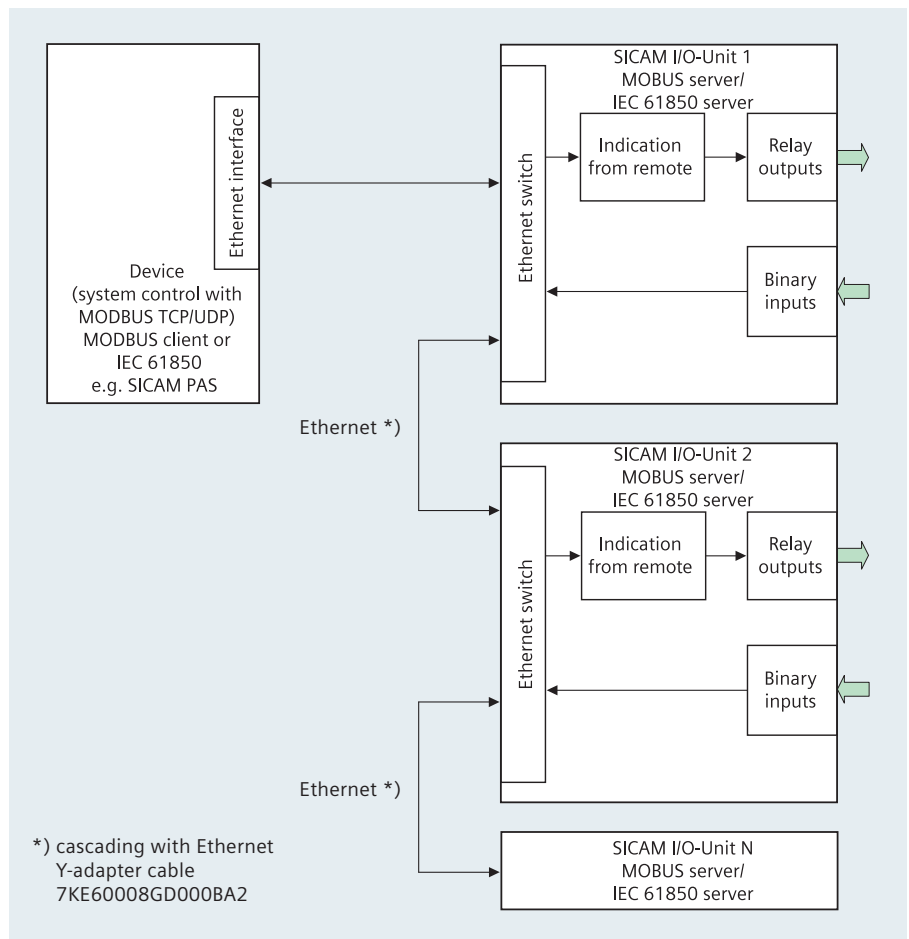

Fig. 13/21 I/O expansion of a substation with binary inputs and outputs

## Application

### Uni-directional binary signal transmission

Instead of using an Ethernet network there is also the option of serial connection with MODBUS RTU protocol. The link can be done by a RS485-bus line structure or an optical star network.

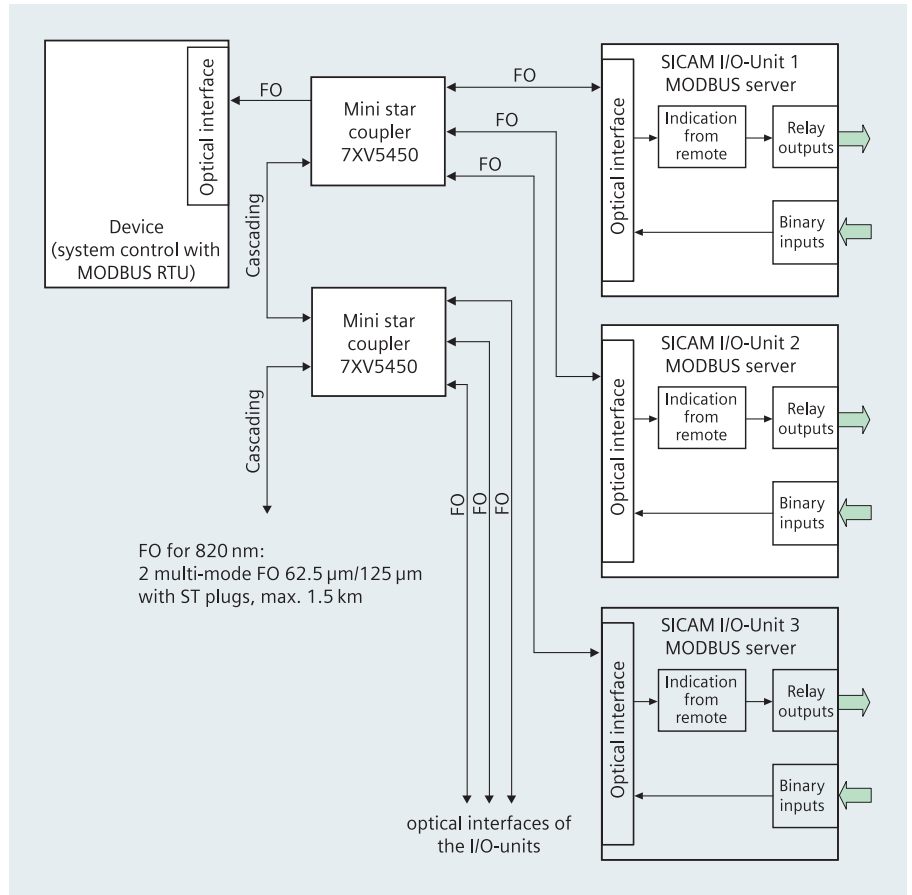

Fig. 13/22 I/O expansion for the connection to substation controller using a serial optical star topology

### Contact multiplier

Input signals on one or more binary inputs can be assigned to binary outputs of the local device (Fig. 13/23)

- 1 binary signal on up to 6 relay outputs
- Several binary signals to several relay outputs assignable by the user
- Different voltage levels for inputs and outputs in a wide voltage range to isolate between different voltage levels.

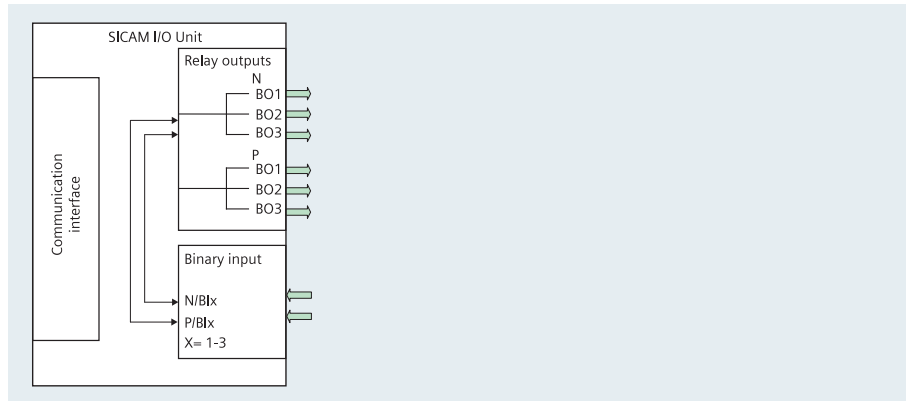

Fig. 13/23 Contact multiplier

### Applications for remote transmission of binary signals

#### Binary signal transmission via communication networks using a G.703.1/X.21 interface

The picture shows the optical connection of an SICAM I/O-Unit to a communication converter (KU-XG) 7XV5662-0AA01, which establishes a connection to a multiplexer with G.703.1 or X.21 interface. This allows the use of this communication converter to transfer the signals via communication network. The average delay time in the network and the signal quality is monitored by the SICAM I/O-Unit. Also loss of connection is indicated. In this case, the state of the binary outputs can be set by the user to a safe condition depending on the application.

A maximum of 6 binary single signals can be transmitted bi-directional via the communication network.

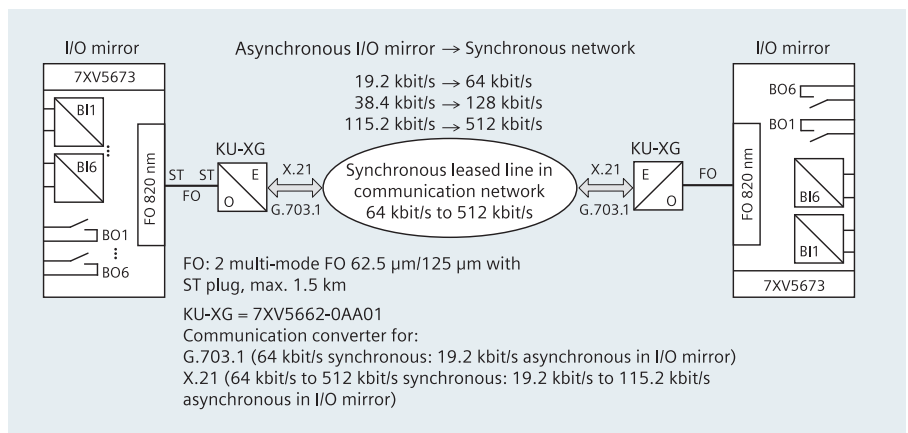

Fig. 13/24 Binary signal exchange over a communication converter with G.703.1/X.21 interface via a communication network

## Application

### Binary signal transmission via two-wire copper cable with blocking

The picture shows the optical connection of an SICAM I/O-Unit to a communication converter 7XV5662-0AC01, which establishes a connection via pilot wire. Only one pair is necessary for bi-directional signal exchange.

An additional isolation transformer allows 20 kV isolation from the pilot wire connection.

A maximum of 6 binary single signals can be transmitted bi-directionally over the pilot wire. The additional delay caused by the transfer over the communication converter and pilot wire is less than 1 ms.

A typical application is the signal comparison of a directional overcurrent protection device via pilot wires. In this case, the definite overcurrent protection device is connected to the SICAM I/O-Unit via contacts and binary inputs and directional signals are transferred.

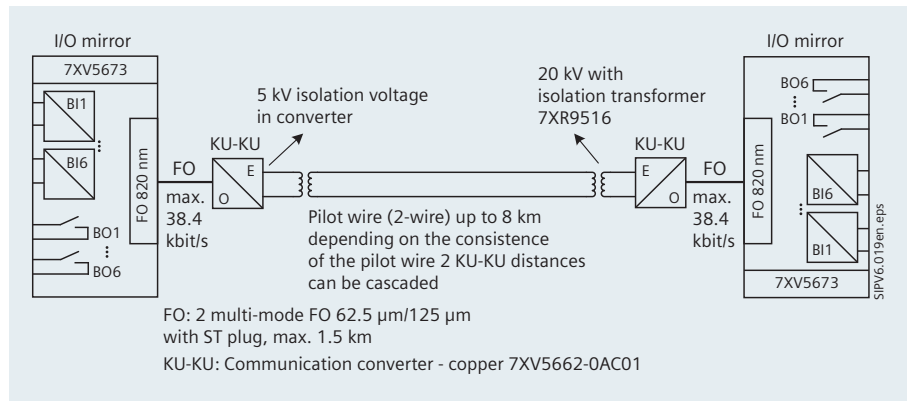

Fig. 13/25 Binary signal exchange of 6 signals via pilot wire connection

### Binary signal exchange of over long fiber optic links

The figure shows the optical connection of an SICAM I/O-Unit to a serial optical repeater 7XV5461-0BX00, which establishes a connection to multi-mode or single-mode fiber cables. A max. distance of 170 km can be reached with this application without additional amplifiers.

A maximum of 12 binary signals can be exchanged via long fiber optical connections because the repeater allows connecting two SICAM I/O-Units.

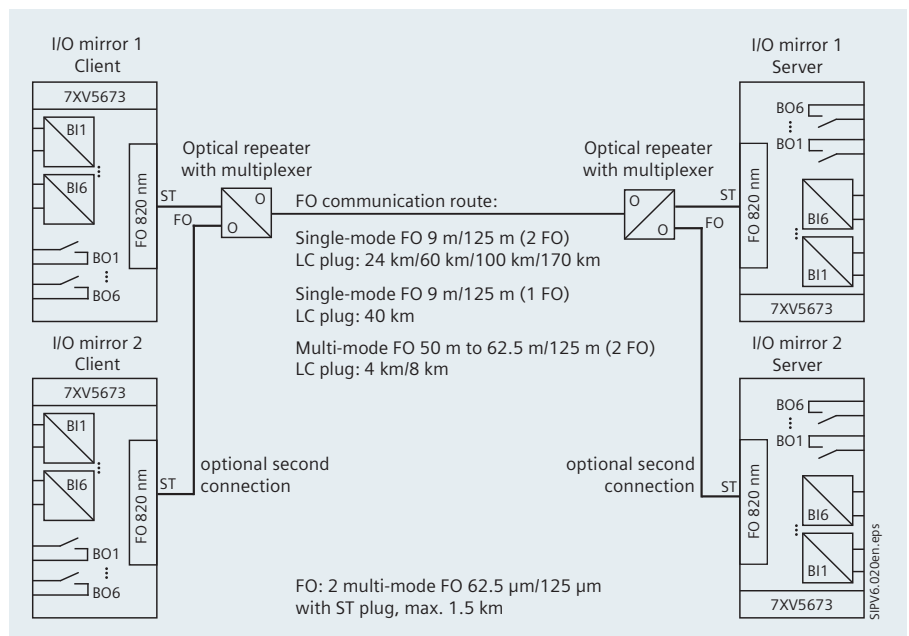

Fig. 13/26 Binary signal exchange of up to 12 signals over long fiber optic links

### Binary signal transmission via a communication networks using a G.703.6 interface

The figure shows the optical connection of one up to three SICAM I/O-Units to a communication converter KU-2M 7XV5662-0AD00, which establishes a connection to a multiplexer with a G.703.6 interface (1.44 kbit/s/2 Mbit/s, E1/T1).

A maximum of 18 binary single signals can be transmitted bi-directionally over the communication network. The KU-2M is provided with two optical and one electrical RS232 interface. Two SICAM I/O-Units can be directly connected by an optical cable to the KU-2M. On the RS232 interface, an additional SICAM I/O-Unit can be connected via an optoelectronic converter. Using all input interfaces (2 FO, 1 RS232) of the KU-2M, a maximum of 18 signals can be exchanged bi-directionally.

For long distance connections via Ethernet media converters or Ethernet networks can be used. The SICAM I/O-Unit supports IP – address settings and settings for a standard gateway. The electrical Ethernet interface of the SICAM I/O-Unit is connected to a media converter or switch which transfer the signals of the units over long distance Ethernet connections. The average delay time in the network is measured by the SICAM I/O-Unit.

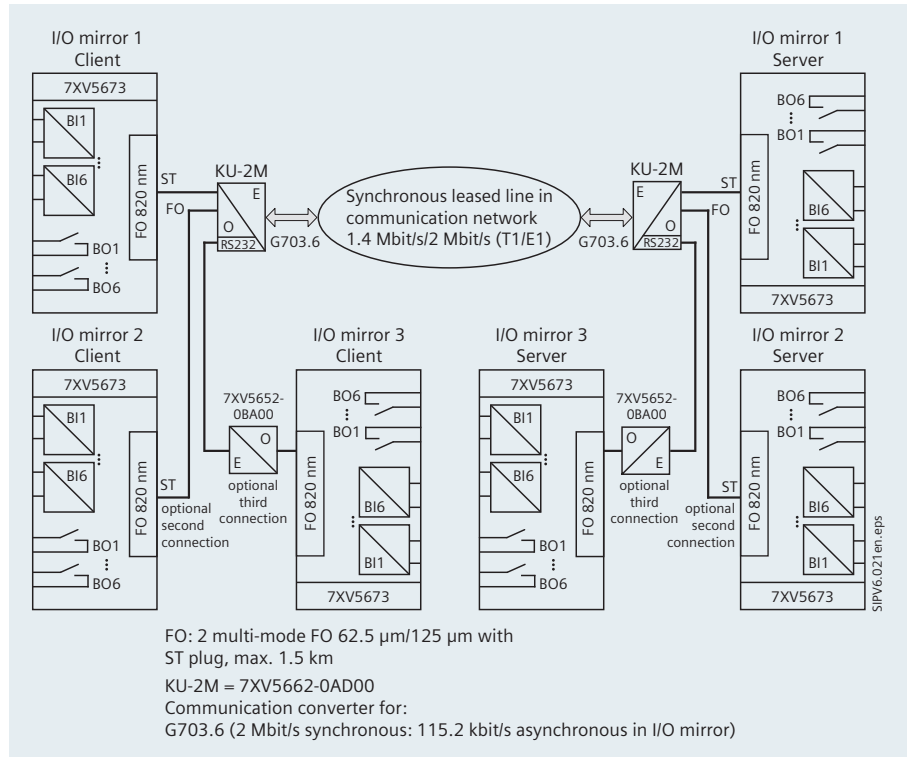

Fig. 13/27 Binary signal exchange with G.703.6 interface via a communication network

### Device configuration

The SICAM I/O-Unit is equipped with an integrated Web Server which allows easy setting using standard Internet-Browsers. Fig. 13/28 shows the User interface. All settings are done with the Browser. Also operational log and commissioning aid are supported by the Browser like the indication of the actual state of the inputs and outputs.

For configuring the IEC 61850-GOOSE Subscriber-Configuration, the SICAM I/O Mapping Tool is used. When the substation configuration is ready, the SICAM I/O Mapping reads the SCD data of the substation configuration and creates a binary IEC 61850 parameter set, which can be uploaded over HTML.

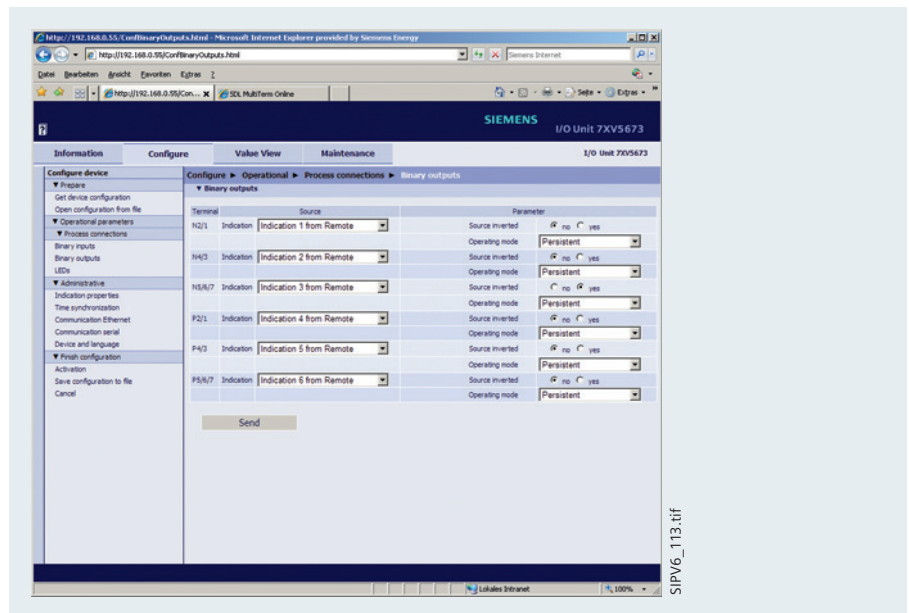

Fig. 13/28 Configuration screen of the SICAM I/O-Unit in the Browser

## Application example/Selection and ordering data

### Binary signal transmission via a optical-fiber or wireless connection

The application (figure 13/29) shows the electric connection of a SICAM I/O-Unit 7XV5673 to Ethernet-based transmission devices via patch cable, which establish a connection via optical fibers on the remote side or a wireless connection. The connection could also be realized via switches with long-distance modules or via IP networks.

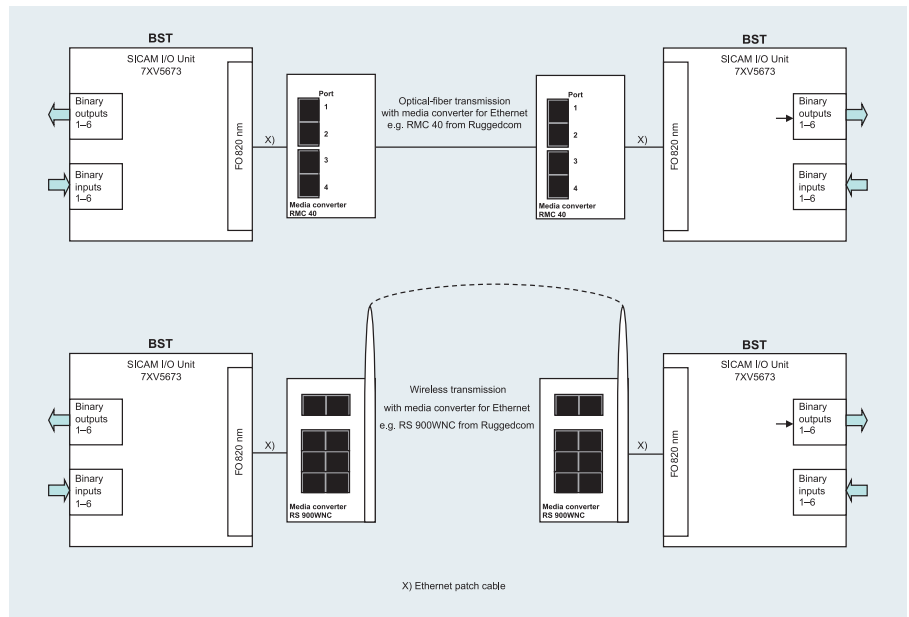

Fig. 13/29 Binary signal transmission via optical fibers or wireless connection; connection via the integrated Ethernet interface to external transmission devices

### Technical data/Selection and ordering data

#### Housing

Dimensions	96 × 96 × 100 mm (W × H × D)
Protection class	IP20
Assembly	DIN rail

#### In- and output

Binary input	6 with setting threshold voltage
Relais output	6 (2 make contact, 1 change-over contact)

#### Serial interface

without serial communication  
 RS485 – MODBUS RTU, binary signal transmission  
 optical, 820 nm – MODBUS RTU, binary signal transmission

#### Communication interface and communication protocol

Ethernet interface with MODBUS TCP/UDP or binary signal transmission  
 Ethernet interface with MODBUS TCP/UDP, binary signal transmission or IEC 61850 (GOOSE, MMS, Reporting)

#### Specials

Integrated Ethernet switch

Description	Order No.
SICAM I/O-Unit, integrated electrical Ethernet interface, RJ45 connector	7XV5673-0JJ□0-□AA1
<b>Serial interface and communication protocol</b>	
Without serial communication	0
RS485 – MODBUS RTU, binary signal transmission	1
Optisch, 820 nm – MODBUS RTU, binary signal transmission	2
<b>Communication interface and communication protocol</b>	
Ethernet interface with MODBUS TCP/UDP or binary signal transmission	1
Ethernet interface with MODBUS TCP/UDP, binary signal transmission or IEC 61850 (GOOSE, MMS, Reporting)	2
<b>Accessories</b>	
Y cable	7KE6000-8GD00-0BA2