

Measurement Transducer

The 7SJ63 device with the large graphic display can be selected with transducer inputs (ordering option). In addition to the normal current and voltage measurement inputs, two additional transducer measuring inputs are provided in this case. These have a measuring range from 0mA to 20mA .

In the default settings, the measurement transducers are configured to measure and monitor pressure and temperature values. This can be changed for other applications. The type of value is not of consequence. A list for selecting the matching units/dimensions of the measured values and monitoring thresholds is provided.

The default settings already contain a number of options. Please refer to this in the input/output matrix.

	Information			Source		Destination										
	No.	Display text:	Long text:	Type	BI	F	C	BO	LED	Buffer			S	C	B	CM
										O	S	T				
Device						*		*	*		*	*				
P.System Data 1									*		*					
Osc. Fault Rec.						*			*		*	*				
P.System Data 2							*	*	*	*	*	*				
Overcurrent								*	*	*	*	*				
Directional O/C								*	*	*	*	*				
Measurerm.Superv							*	*	*	*	*	*				
Fault Locator									*	*	*	*				
Cntrl Authority									*	*	*	*				
Control Device						*	*	*	*	*	*	*	*	*	*	*
Process Data								*	*	*	*	*	*	*	*	*
Measurement		Superv.Pressure	Supervision Pressure	OUT			X			00						
		Superv.Temp.	Supervision Temperature	OUT			X			00						
Demand meter									*							
Min/Max meter									*							
Set Points(MV)	00273	SP. IL1 dmd>	Set Point Phase L1 dmd>	OUT			X			00		X				
	00274	SP. IL2 dmd>	Set Point Phase L2 dmd>	OUT			X			00		X				
	00275	SP. IL3 dmd>	Set Point Phase L3 dmd>	OUT			X			00		X				
	00276	SP. I1 dmd>	Set Point positive sequence I1 dmd>	OUT			X			00		X				
	00277	SP. Pdmd >	Set Point Pdmd >	OUT			X			00		X				
	00278	SP. Qdmd >	Set Point Qdmd >	OUT			X			00		X				
	00279	SP. Sdmd >	Set Point Sdmd >	OUT			X			00		X				
			SP. Pressure<	Set Point Pressure<	OUT			X			00					
		SP. Temp>	Set Point Temp>	OUT			X			00						
	00284	SP. I<	Set Point I< alarm	OUT			X			00		X				
	00285	SP. PF(55)alarm	Set Point 55 Power factor alarm	OUT			X			00		X				
Energy									*							
Statistics									*							
SetPoint(Stat)									*		*					

Picture 1: input-output matrix with measurement transducer annunciations

Information concerning the measurement transducers is shown in the I/O matrix for both the views *indications and commands only* as well as the view *measured & metered values only* (refer to Picture 1 and 2).

	Information				Source		Destination						
	No.	Display text:	Long text:	Type	B	C	Measured value	Measured value window	S	C	Metered value window	B	D
Measurement	00606	I2 =	I2 (negative sequence)	MV							X		
	00631	3I0 =	3I0 (zero sequence)	MV							X		
	00621	UL1E=	U L1-E	MV						X	X		
	00622	UL2E=	U L2-E	MV						X	X		
	00623	UL3E=	U L3-E	MV						X	X		
	00624	UL12=	U L12	MV						X	X		
	00625	UL23=	U L23	MV						X	X		X
	00626	UL31=	U L31	MV						X	X		
	00627	Uen =	Uen	MV							X		
	00629	U1 =	U1 (positive sequence)	MV							X		
	00630	U2 =	U2 (negative sequence)	MV							X		
	00641	P =	P (active power)	MV						X	X		
	00642	Q =	Q (reactive power)	MV						X	X		
	00645	S =	S (apparent power)	MV							X		
	00644	Freq=	Frequency	MV						X	X		
	00832	3U0 =	3U0 (zero sequence)	MV							X		
	00901	PF =	Power Factor	MV							X	X	
	00996	Td1=	Transducer 1	MV							X	X	
00997	Td2=	Transducer 2	MV							X	X		
	Press =	Pressure	MVU		X			Operation. pri					
	Temp =	Temperature	MVU		X			Operation. pri					
Demand meter											*		
Min/Max meter													
Set Points(MV)		IL1 dmd>	IL1 dmd>	LV				Set Points(MV)		X			
		IL2dmd>	IL2 dmd>	LV				Set Points(MV)		X			
		IL3dmd>	IL3 dmd>	LV				Set Points(MV)		X			
		I1 dmd>	I1 dmd>	LV				Set Points(MV)		X			
		Pdmd >	Pdmd >	LV				Set Points(MV)		X			
		Qdmd >	Qdmd >	LV				Set Points(MV)		X			
		Sdmd >	Sdmd >	LV				Set Points(MV)		X			
		Press<	Pressure<	LVU				Set Points(MV)		X			
		Temp>	Temp>	LVU				Set Points(MV)		X			
Energy		IL<	IL< under current	LV				Set Points(MV)		X			
		PF <	Power Factor <	LV				Set Points(MV)		X			
Statistics						*			*	*			
SetPoint(Stat)													

Picture 2: input-output matrix with measured values for measurement transducers

When opening the default CFC chart called *Transducer 20mA Input*, the standard use of the annunciation and measurement values can be seen (see picture 5).

Initially the monitored values Td1 (transducer 1) and Td2 (transducer 2) are connected to the LIVE_ZERO gate. The function of this gate is to suppress transducer errors or interference signals by restricting the indication range so that values below a defined threshold called LIVE_ZERO (usually 20%) are rejected. If the signal is below the LIVE_ZERO threshold, the gate generates an annunciation stating this condition.

The LIVE_ZERO gate shown in the CFC charts may differ from the LIVE_ZERO gate presented in this document. The LIVE_ZERO gate properties may be modified such that certain inputs will be displayed or not. To do this, click on the gate with the right mouse button, then click the object properties and refer to the second tag I/O for the table of options.

The Val inputs of the LIVE_ZERO gates are connected to Td1 (transducer 1) and Td2 (transducer 2) measurement values. In picture 3 and 4 the response of this gate may be seen.

Note: The LiveZero, DetectKnee and DispKnee inputs can be configured via the Object Properties context menu command of the block.

With the default settings the gate begins to transmit the measurement value >20% and at 50% the gate will change the response as shown in picture 4. In case a knee point is not required, the ZERO_POINT gate is more appropriate.

The output of the LIVE_ZERO gates consists of a measurement value and an annunciation. When the annunciation is present, this indicates the presence and validity of the measured value. The annunciation is shown in the I/O matrix picture 1 .

The measured value coming from the LIVE_ZERO gate is of greater interest. It is routed to:

1. a LOWER_SETPOINT (or UPPER_SETPOINT) gate
2. directly to the right border=output of the CFC chart.

In case of a direct output of the measured value to the input/output matrix the unit/dimension of the resultant value must be defined. In picture 2 these are the measured values *Press =* and *Temp =* contained in the group *Measurement* with SOURCE CFC.

Click on these measured values with the right mouse button, then choose which unit/dimension and conversion factor shall be displayed.

I/O Assignment:

	Name	Data type	Comment	Default setting
Inputs:	Val	Real	Measured value	0.0
	LiveZero	Real	Live zero value in % (≥ 0.0 %)	20.0
	DetectKnee	Real	Dected knee point in % (≥ 0.0 % and ≤ 100.0 %)	50.0
	DispKnee	Real	Displayed knee point in % (0.0...200.0 %)	70.0
Outputs:	Result	Real	Live zero measured value in %	0.0
	Annunc	Bool	Indication: live zero monitoring	0

Picture 3 : inputs and outputs of the LIVE_ZERO gate

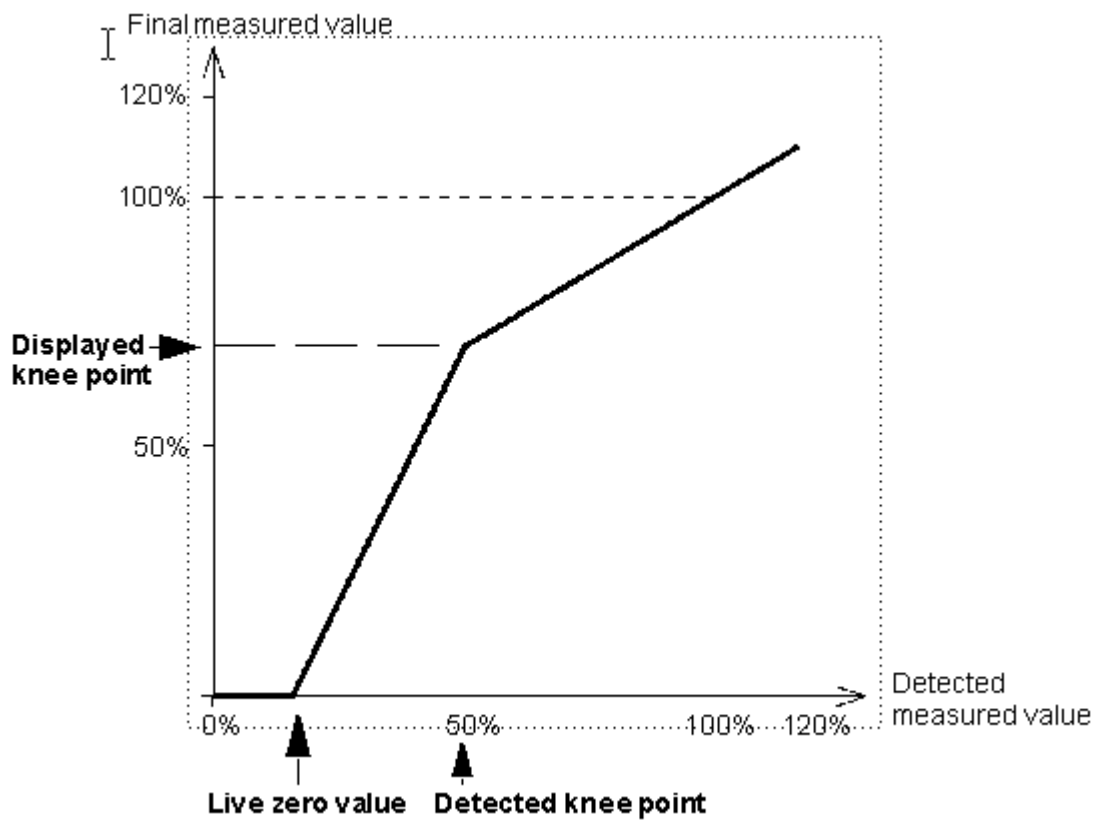

Picture 4 : Response of displayed value relative to monitored value

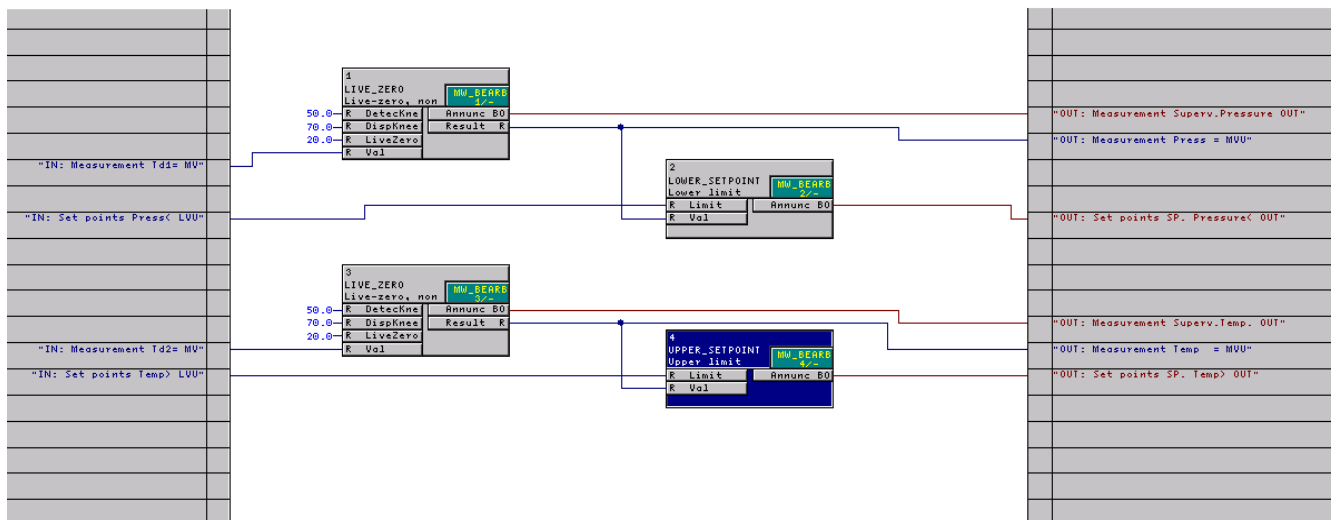

Picture 5 : CFC chart *Transducer 20mA Input*

To monitor the transducer measured values, the thresholds must be checked. For this purpose, the result output of the LIVE_ZERO gate is routed to a LOWER_SETPOINT or UPPER_SETPOINT_gate.

In the CFC chart the measured value for pressure will be monitored to detect low pressure while the temperature value will be monitored to detect a high value. The results will be the annunciations in the group SetPoints in the I/O matrix (see picture 1).

The thresholds of the LOWER_SETPOINT and/or UPPER_SETPOINT gate will be set in the input/output matrix. In picture 2 (*view measured & metered values only*), in the group *Set Points* the pressure and temperature settings may be changed by clicking the appropriate value with the right mouse button.