

IF IN DOUBT ASK
DO NOT SCALE

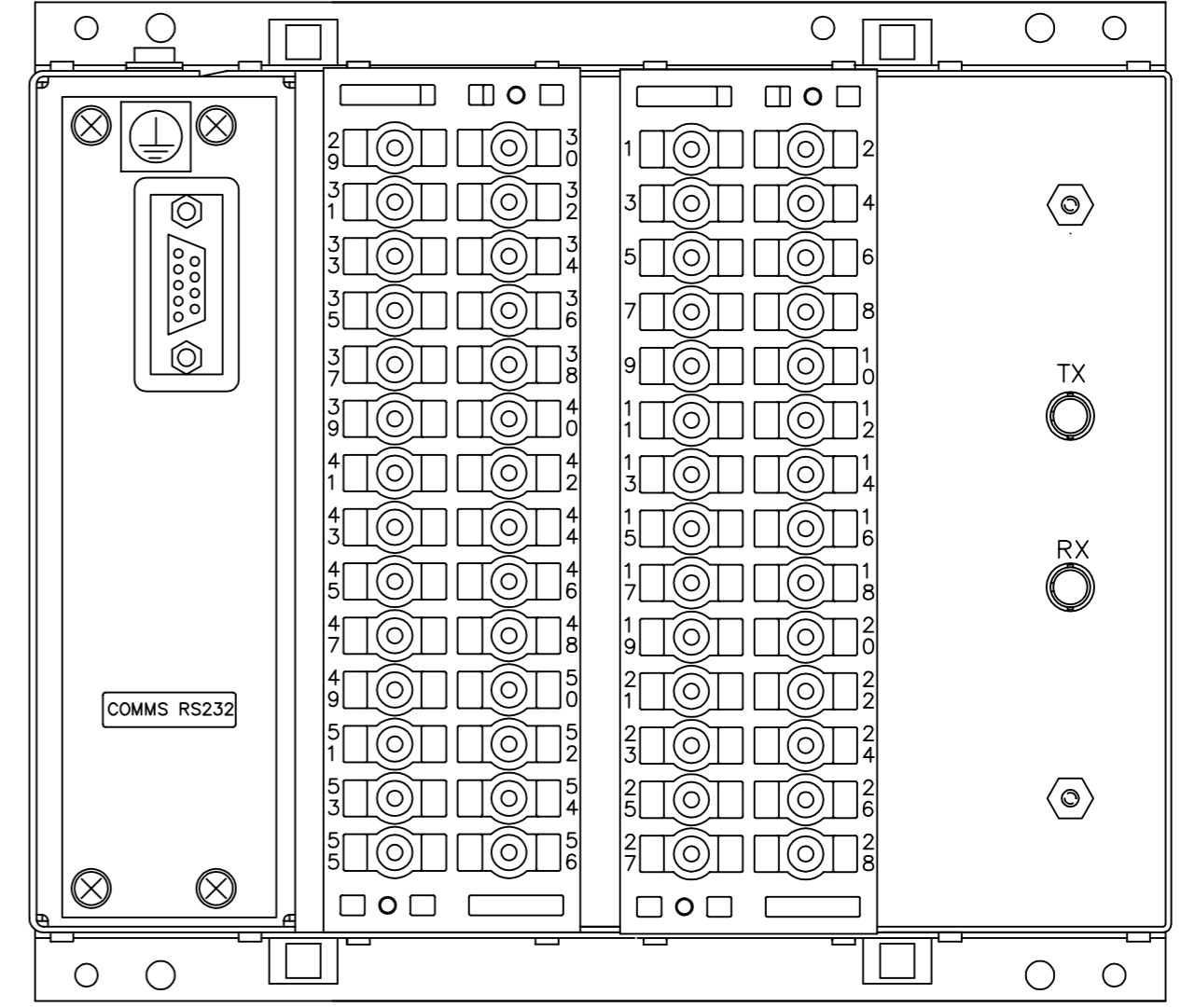
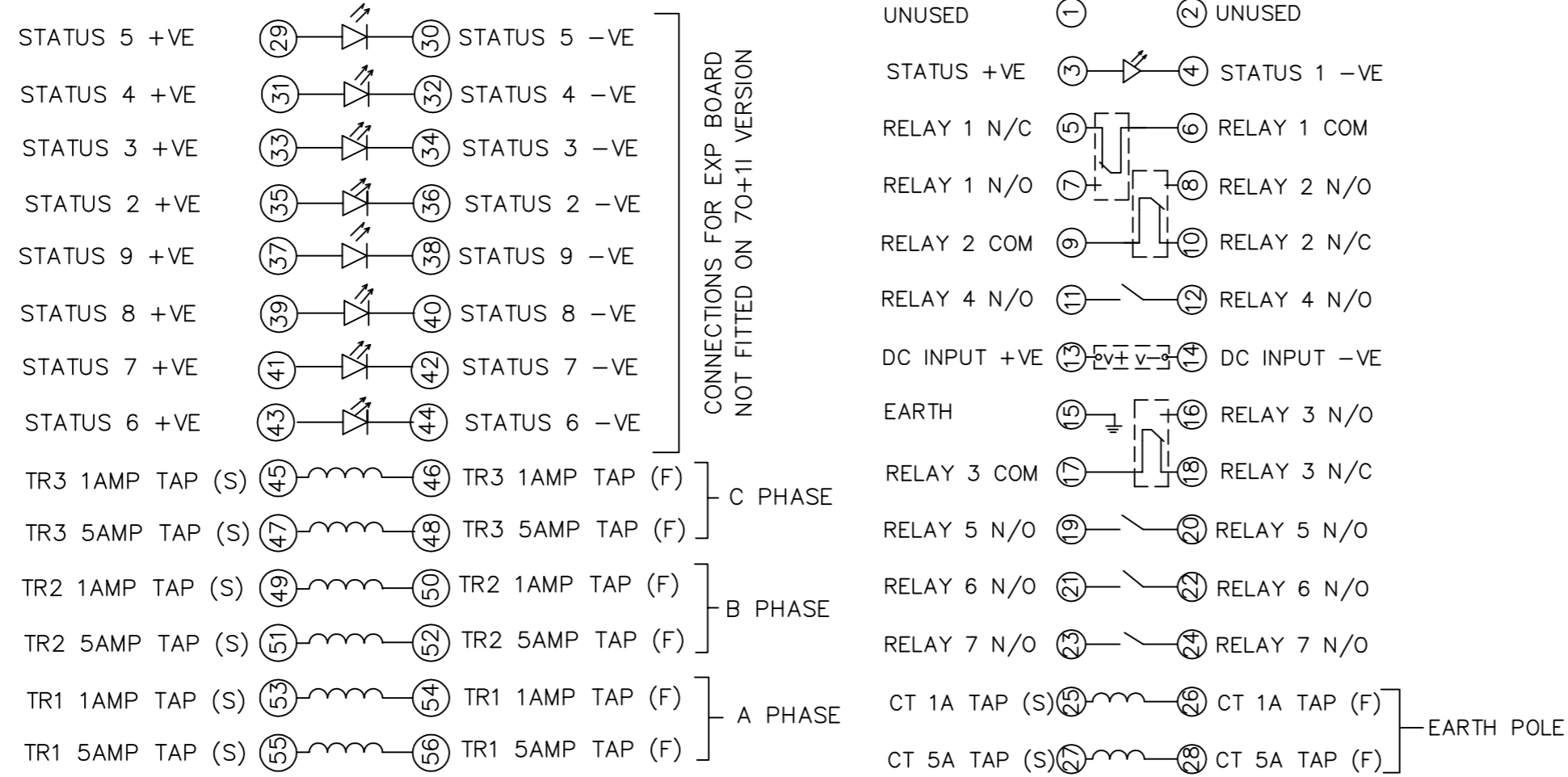

OUTER TERMINAL BLOCK ASSY: -
VIEW BLOCK FROM THE INSIDE FACE
ASSEMBLY INSTRUCTIONS: -
TYPICAL ASSEMBLY DRAWING 2995G10029
AT INDICATED POSITIONS FIT AS FOLLOWS,
S - FIT STANDARD CONTACT
2995B10051
HC - FIT 'HEAVY CURRENT' KIT
2995G10030
WHERE -o-o- IS SHOWN FIT
CT SHORTING KIT 2995G10031
POSITIONS SHOWN BLANK ARE UNUSED
ALL POSITIONS FIT SCREW 2106F12506

30	S	S	29
32	S	S	31
34	S	S	33
36	S	S	35
38	S	S	37
40	S	S	39
42	S	S	41
44	S	S	43
46	-o-o-		45
48	-o-o-		47
50	-o-o-		49
52	-o-o-		51
54	-o-o-		53
56	-o-o-		55

OUTER TERMINAL BLOCK ASSY: -
VIEW BLOCK FROM THE INSIDE FACE
ASSEMBLY INSTRUCTIONS: -
TYPICAL ASSEMBLY DRAWING 2995G10029
AT INDICATED POSITIONS FIT AS FOLLOWS,
S - FIT STANDARD CONTACT
2995B10051
HC - FIT 'HEAVY CURRENT' KIT
2995G10030
WHERE -o-o- IS SHOWN FIT
CT SHORTING KIT 2995G10031
POSITIONS SHOWN BLANK ARE UNUSED
ALL POSITIONS FIT SCREW 2106F12506

2	S	S	1
4	S	S	3
6	S	S	5
8	S	S	7
10	S	S	9
12	S	S	11
14	S	S	13
16	S	S	15
18	-o-o-		17
20	S	S	19
22	S	S	21
24	S	S	23
26	-o-o-		25
28	-o-o-		27

VIEW FROM NUMBERED SIDE OF BLOCK
ASSEMBLY INSTRUCTIONS: -
TYPICAL ASSEMBLY DRAWING 2995G10032
AT INDICATED POSITIONS FIT AS FOLLOWS,
T - FIT TRIP ISOLATION CONTACT
2995B10053
S - FIT STANDARD CONTACT
2995B10054
POSITIONS SHOWN BLANK ARE UNUSED

2	T	T	1
4	T	T	3
6	T	T	5
8	T	T	7
10	T	T	9
12	T	T	11
14	T	T	13
16	T	T	15
18	S	S	17
20	S	S	19
22	S	S	21
24	S	S	23
26	S	S	25
28	S	S	27

VIEW FROM NUMBERED SIDE OF BLOCK
ASSEMBLY INSTRUCTIONS: -
TYPICAL ASSEMBLY DRAWING 2995G10032
AT INDICATED POSITIONS FIT AS FOLLOWS,
T - FIT TRIP ISOLATION CONTACT
2995B10053
S - FIT STANDARD CONTACT
2995B10054
POSITIONS SHOWN BLANK ARE UNUSED

2	S	S	1
4	T	T	3
6	S	S	5
8	T	T	7
10	S	S	9
12	T	T	11
14	S	S	13
16	T	T	15
18	S	S	17
20	T	T	19
22	T	T	21
24	T	T	23
26	S	S	25
28	S	S	27

NOT SUBJECT TO UPDATE
ONCE COPIED / PRINTED
OR DOWNLOADED

NOTES
1 TERMINALS RECOMMENDED ARE PRE INSULATED & MUST BE CRIMPED USING APPROVED TOOLING.
AMP PIDG OR PLASTI GRIP FUNNEL ENTRY (RING TONGUE) FOR M4 FIXING STUD.
SUPPLIER AMP CABLE SIZE
AMP 342103 0.25-1.6 SQ MM
AMP 342143 1.0-2.6 SQ MM.
OR ANY OTHER MANUFACTURERS EQUIVALENT TERMINAL.
2 FOR OUTLINE & DRILLING DRG SEE 2995X10008 (A4).

MATERIAL:
Dimensions in millimetres ; Surface texture in micrometres.
Machine where marked ✓
For explanation of dimensions, tolerances, notes etc. see B.S.308.
Limit on untoleranced unmachined dimensions ± _____
Limits on untoleranced machined dimensions to B.S.4500; i.e. up to 6±0.1; over 30 to 120±0.3; over 315±0.8; over 6 to 30±0.2; over 120 to 315±0.5;
General unmachined angular tolerance ± _____

Copyright © 2004 VATECH REYROLLE ACP Ltd. Hebburn	1	19/09/04	CHANGE
	ISSUE	DATE	NOTED
First used on:			
Similar Articles:			
Supersedes:			
Original Scale:	Dr. No.	2646W50005	
VATECH REYROLLE AUTOMATION, CONTROL & PROTECTION	NTS		
DATE 17/09/04	IE	OPS	PCP
		Purch.Spec.	TQ
		EAC	CE
		STD	A2