

IF IN DOUBT ASK  
DO NOT SCALE

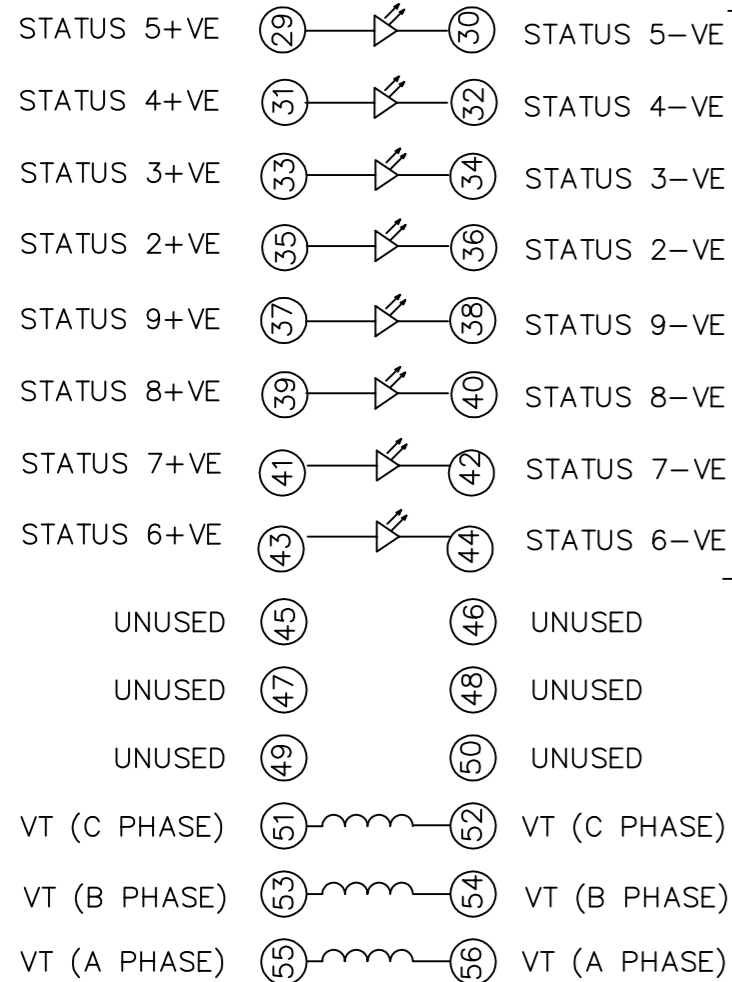

OUTER TERMINAL BLOCK ASSY:-  
VIEW BLOCK FROM THE INSIDE FACE

ASSEMBLY INSTRUCTIONS:-

TYPICAL ASSEMBLY DRAWING 2995G10029  
AT INDICATED POSITIONS FIT AS FOLLOWS,  
S - FIT STANDARD CONTACT  
2995B10051

30	S	S	29
32	S	S	31
34	S	S	33
36	S	S	35
38	S	S	37
40	S	S	39
42	S	S	41
44	S	S	43
46	S	S	45
48	S	S	47
50	S	S	49
52	S	S	51
54	S	S	53
56	S	S	55

HC - FIT 'HEAVY CURRENT' KIT  
2995G10030

WHERE  $\ominus$  IS SHOWN FIT  
CT SHORTING KIT 2995G10031

POSITIONS SHOWN BLANK ARE UNUSED  
ALL POSITIONS FIT SCREW 2106F12506

CHASSIS TERMINAL BLOCK ASSY:-  
VIEW FROM NUMBERED SIDE OF BLOCK

ASSEMBLY INSTRUCTIONS:-

TYPICAL ASSEMBLY DRAWING 2995G10032  
AT INDICATED POSITIONS FIT AS FOLLOWS,  
T - FIT TRIP ISOLATION CONTACT  
2995B10053

2	T	T	1
4	T	T	3
6	T	T	5
8	T	T	7
10	T	T	9
12	T	T	11
14	T	T	13
16	T	T	15
18	S	S	17
20	S	S	19
22	S	S	21
24	S	S	23
26	S	S	25
28	S	S	27

S - FIT STANDARD CONTACT  
2995B10054

POSITIONS SHOWN BLANK ARE UNUSED

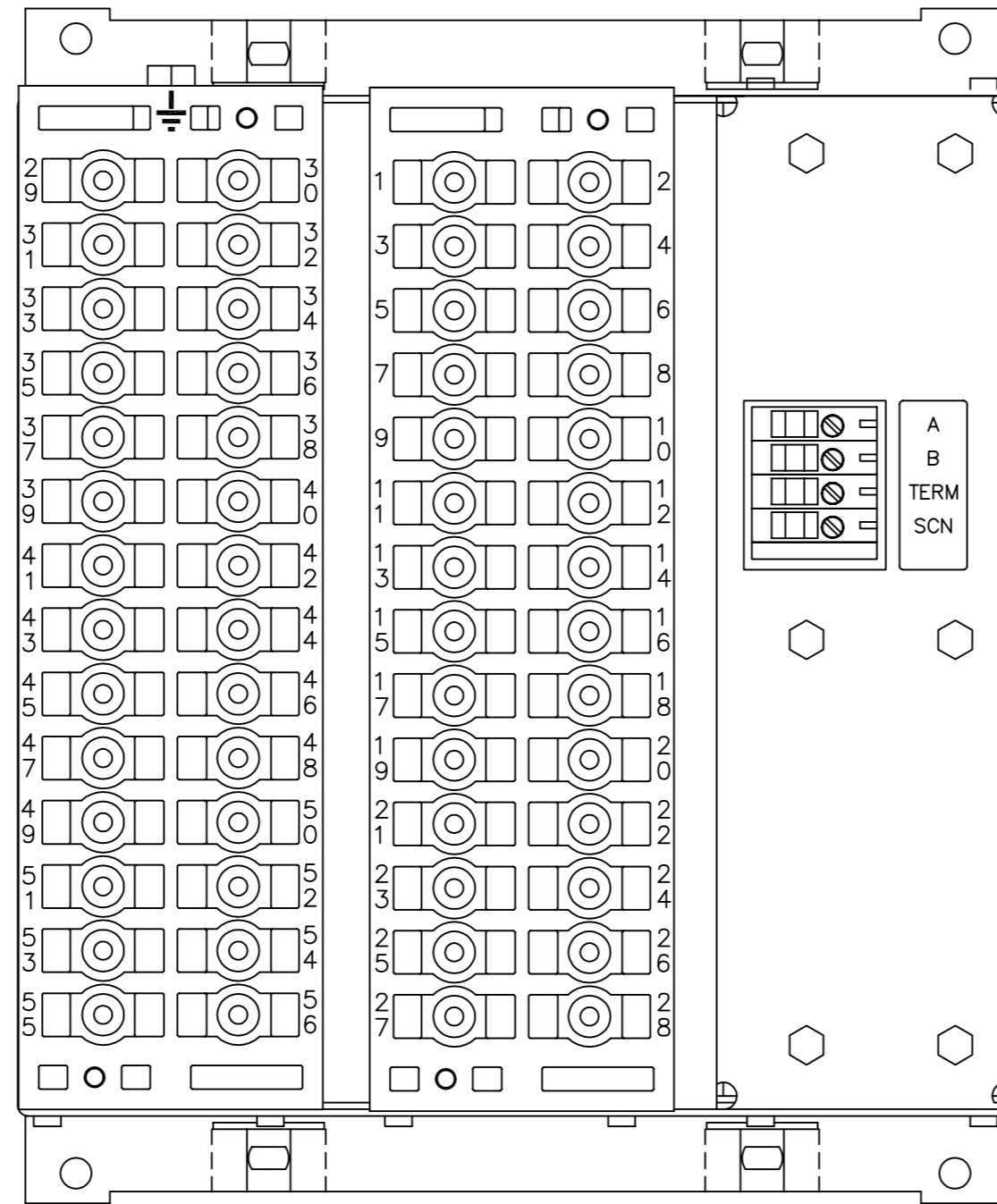

BOX VIEWED FROM REAR

PROTECTION TYPE	SCHEMATIC DIAGRAM OPTION B	SCHEMATIC DIAGRAM OPTION C
PHASE/PHASE	2422W10010 (A3)	2422W10011 (A3)
PHASE/NEUTRAL	2422W10012 (A3)	2422W10013 (A3)

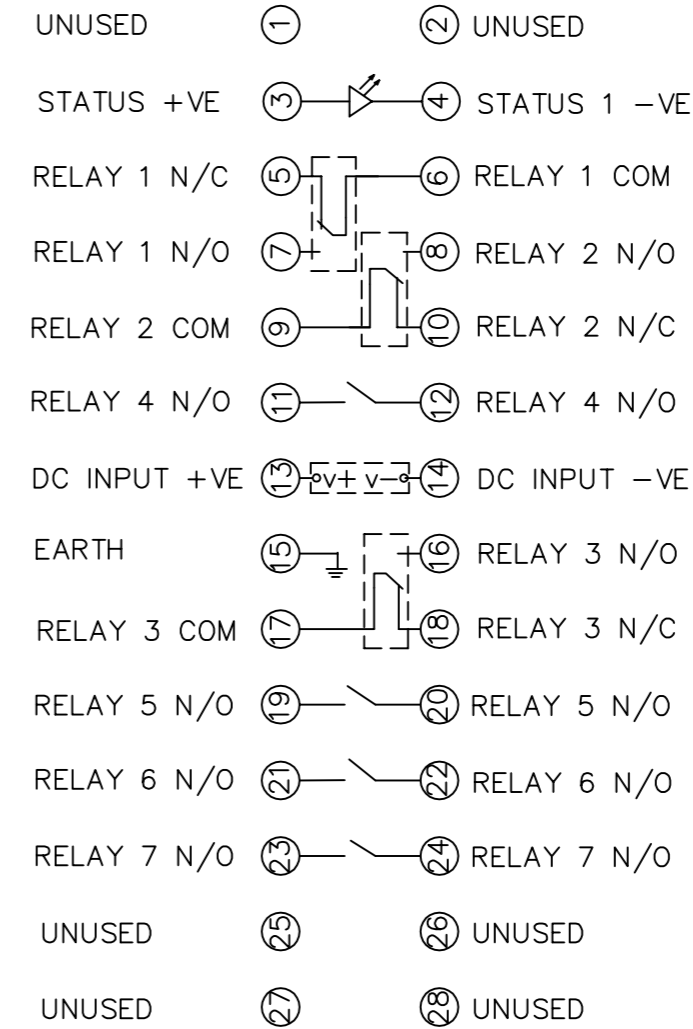

OUTER TERMINAL BLOCK ASSY:-  
VIEW BLOCK FROM THE INSIDE FACE

ASSEMBLY INSTRUCTIONS:-

TYPICAL ASSEMBLY DRAWING 2995G10029  
AT INDICATED POSITIONS FIT AS FOLLOWS,  
S - FIT STANDARD CONTACT  
2995B10051

2	S	S	1
4	S	S	3
6	S	S	5
8	S	S	7
10	S	S	9
12	S	S	11
14	S	S	13
16	S	S	15
18	S	S	17
20	S	S	19
22	S	S	21
24	S	S	23
26	S	S	25
28	S	S	27

HC - FIT 'HEAVY CURRENT' KIT  
2995G10030

WHERE  $\ominus$  IS SHOWN FIT  
CT SHORTING KIT 2995G10031

POSITIONS SHOWN BLANK ARE UNUSED  
ALL POSITIONS FIT SCREW 2106F12506

CHASSIS TERMINAL BLOCK ASSY:-  
VIEW FROM NUMBERED SIDE OF BLOCK

ASSEMBLY INSTRUCTIONS:-

TYPICAL ASSEMBLY DRAWING 2995G10032  
AT INDICATED POSITIONS FIT AS FOLLOWS,  
T - FIT TRIP ISOLATION CONTACT  
2995B10053

2	S	S	1
4	T	T	3
6	S	S	5
8	T	T	7
10	S	S	9
12	T	T	11
14	S	S	13
16	T	T	15
18	S	S	17
20	T	T	19
22	T	T	21
24	T	T	23
26	S	S	25
28	S	S	27

S - FIT STANDARD CONTACT  
2995B10054

POSITIONS SHOWN BLANK ARE UNUSED

NOT SUBJECT TO UPDATE  
ONCE COPIED / PRINTED  
OR DOWNLOADED

NOTES

- TERMINALS RECOMMENDED ARE PRE INSULATED & MUST BE CRIMPED USING APPROVED TOOLING. AMP PIDG OR PLASTI GRIP FUNNEL ENTRY (RING TONGUE) FOR M4 FIXING STUD.  
SUPPLIER AMP CABLE SIZE  
AMP 342103 0.25-1.6 SQ MM  
AMP 342143 1.0-2.6 SQ MM.  
OR ANY OTHER MANUFACTURERS EQUIVALENT TERMINAL.
- FOR OUTLINE & DRILLING DRG SEE 2995X10006 (A4).
- TERMINAL BLOCKS TO BE REFERENCED A & B AS SHOWN.

MATERIAL:

Dimensions in millimetres ; Surface texture in micrometres.  
Machine where marked ✓  
For explanation of dimensions, tolerances, notes etc. see B.S.308.  
Limit on untoleranced unmachined dimensions ± \_\_\_\_\_  
Limits on untoleranced machined dimensions to B.S.4500;  
i.e. up to 6±0.1; over 30 to 120±0.3; over 315±0.8;  
over 6 to 30±0.2; over 120 to 315±0.5;  
General unmachined angular tolerance ± \_\_\_\_\_

Finish:  
Treatment:

Title:  
TERMINAL IDENTIFICATION & RELAY WIRING DIAGRAM  
ARGUS 8 VOLTAGE RELAY 70/P+9SI E6 CASE RS485  
**SIEMENS PROTECTION DEVICES LTD.**  
Original Scale:  
1:1

First used on:  
Similar Articles:  
Supersedes:  
Drg. No.  
2422W50010

Copyright © 2007 Siemens Protection Devices Ltd. Hebburn

1	11/05/07	CHANGE
ISSUE	DATE	NOTED