



Reyrolle  
Protection  
Devices

## 7XG3123 – ReyArc23

Arc Fault Interface Module

Energy Management

**SIEMENS**

# 7XG3123 - RA23

Arc Fault Interface Module



## Features

- Compact, simple, rugged and economic design
- Simple wiring and DIN rail mounting
- Interface for one or two RA30 arc fault sensors
- High speed arc fault tripping output to interface with protection relay status inputs
- Apply to initiate IEC 61850 GOOSE messaging of arc fault events
- Continuous arc fault sensor supervision
- Arc fault pick up and supervision healthy indication
- 24, 32, 48, 110, 125, 220, 240 and 250V DC auxiliary versions

## Introduction

Medium voltage switchgear is a key element in the power supply chain. Existing protection systems operate effectively under most circumstances, but they are too slow to handle arcing short circuits.

Arcing faults can occur as a result of insulation breakdown due to equipment age & / or poor maintenance.

The degree of damage caused by arcing depends principally on the duration of the arc. If an arc lasts only 100ms, the switchgear needs to be checked & the insulation resistance measured before power can be re-established. With a 200ms arc, the power supply will be interrupted; the switchgear must be checked; power is re-established only after minor repairs. In the event of a 500ms arc the supply is interrupted, metal parts of the switchgear are destroyed & poisonous gases are emitted. A 1s arc destroys most of the switchgear & may cause a fire, injury to personnel & damage to property.

The over-current caused by an arc is, due to its resistance, lower than the over-current caused by a "metallic" short circuit. For moderate arc fault currents the trip time of the over-current IDMT stage will be too slow.

The consequence of these conditions is that a protection system based solely on over-current detection cannot effectively protect the switchgear against an internal arcing fault.

## Arc Fault Protection

Arc fault protection is a technique employed for the fast clearance of arcing faults on Busbars & within metal clad switchgear & associated cable boxes. The arc is detected using an optical sensor & the signal input to a protection device which also monitors the load current on the system. A trip signal can be achieved in less than 10ms using arc detection only or within 20ms when using overcurrent check. This is considerably faster than a traditional IDMT overcurrent relay & provides additional protection from the onset of arcing faults with relatively low fault currents.

Arguably the greatest risk of arc fault damage exists at the CB cable termination & in the CB chamber itself due to the slow clearance times of the IDMT feeder protection. The CB cable termination is particularly at risk to ingress of moisture & rodent damage.

The problem of arc faults is most prevalent in older metal clad switchgear which already has operational protection systems.

### RA23 Arc Fault Interface Module

The RA23 (ReyArc23) Arc Fault Interface Module (Arc Module), described in this document is designed to connect one or two optical fault sensors to a protection relay status input. Refer to the RA30 Catalogue Sheet for details on the arc fault sensor ordering options.

## Switchgear Applications

### Switchgear ARC Protection

Risk of arc fault damage exists at the CB cable termination & in the CB chamber itself. The CB cable termination is particularly at risk to ingress of moisture & rodent damage.

RA30 Arc Sensors may be located as depicted in the single line application diagrams (Figure 1).

Modern numeric feeder protection relays provide internal logic functions that may be programmed to interface with the RA23 Module. Refer to figure 6 for details.

Depending on the model of protection relay being used this input may be programmed to provide not only a high speed arc fault trip output but also an alarm message on the HMI and time stamped event record via its communications link.

This level of system integration allows the RA23 Module to be back of panel mounted with the alarm indications programmed to be displayed on the protection relay front panel.

### Cable box protection

Figure 1 shows the trip signal being used to trip the feeder circuit breaker in the event of an arc fault occurring in the cable box provided the overcurrent relay starter logic is picked up.

### CT Chamber protection

In circuit breakers where the CT is screened from the cable box a second sensor and ARC Module may be deployed as per figure 1.

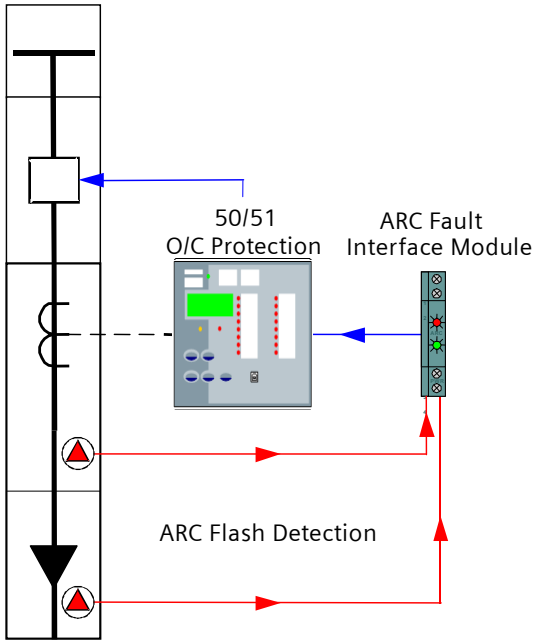

Figure 1: Cable box and CT chamber protection

### Circuit Breaker Chamber Protection

Arc fault occurring within the CB chamber must be cleared by the upstream breaker. This may be achieved as depicted in figure 2. Note the optional use of GOOSE messaging over IEC61850 to communicate an arc fault condition to the incoming feeder protection relays. Programmable logic may then be applied in these relays to open the appropriate up-stream circuit breakers to clear the fault.

Where trip signalling is achieved using conventional wiring, the trip output connection should be terminated in close proximity to the ARC Module and screened cable employed to transfer the trip signal to the up-stream protection relay status input.

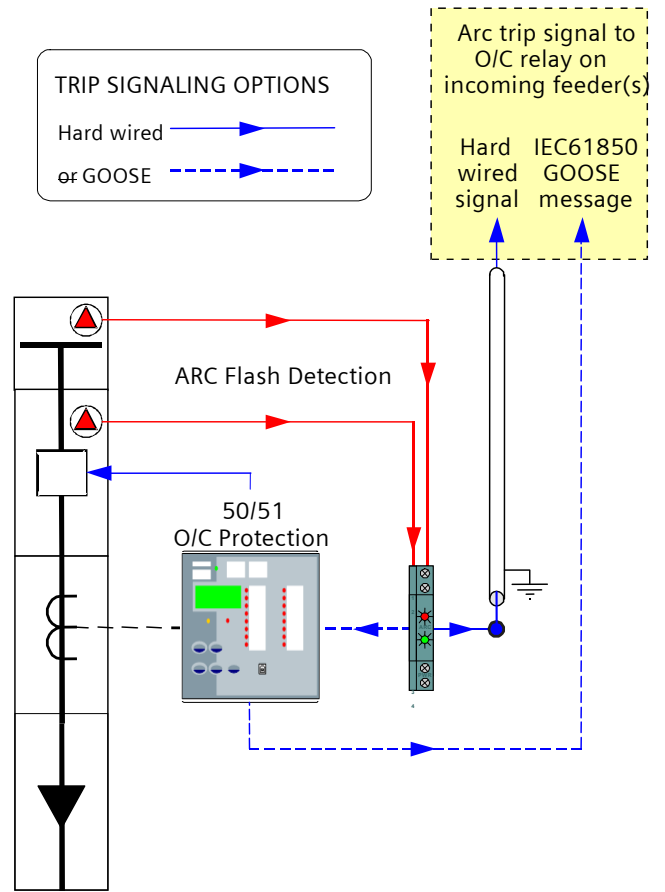

Figure 2: CB chamber protection Arc trip signal to BUS over-current check stage

### Multiple RA23 Interface Modules

Figure 3 depicts multiple RA23 Modules connected to a single status input. This scheme may be employed where more than one sensor is required to protect a single arc protection zone.

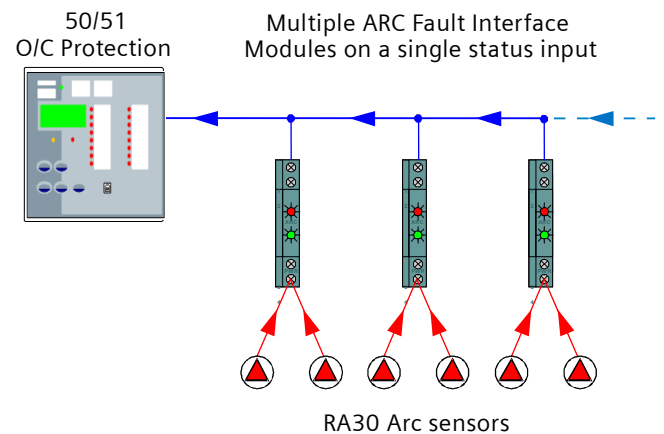

Figure 3: Multiple Arc Modules per status input

## Operation

### Front panel layout

Two LED's are integrated into the front panel to provide the following status indications:

**GREEN** Auxiliary supply indication

A green LED is continuously illuminated to indicate presence of the auxiliary supply and normal operation including supervision of the RA30 sensor(s).

**RED** Arc fault pick-up

A red LED is illuminated when an optical signal above the detection threshold is present. This LED will self reset when the optical signal falls below the detection threshold with a minimum dwell time of ~2s.

This feature is useful during commissioning and routine tests to verify correct operation of the system. Figure 14 provide a tabulation of the LED and output conditions to allow diagnosis of the RA30 operating status.

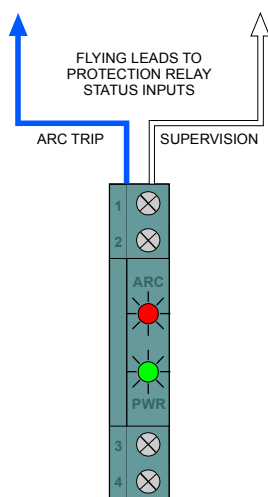

Figure 4: RA23 Module front panel layout

### Arc Sensor continuously picked up

High ambient light levels may cause a RA30 to be continuously picked up. This condition could occur for example if the CB cable box cover was left open in very high ambient light level conditions. A non arc fault over-current pick up would then result in an arc fault trip operation.

To avoid possible mal-operation due to this condition, the RA23 module is designed to automatically disable the arc fault tripping function, if the RA30 sensor is picked up for >500ms. The RA23 Module will then disable the healthy supervision signal and the front power LED will flash until the ambient light level problem is corrected. The ARC Module will then perform an arc sensor test function and automatically reset.

### Arc Detection reset time (effect of multiple arc trips)

A delay of >500ms is required to reset the ARC Module after an initial arc sensor trip. Subsequent arc detection will cause the trip contact to re-operate.

### Arc Sensor function

The RA30 is an optical sensor that responds to the flash of light emitted during the incidence of an arcing fault. Onset of the light flash and detection by the RA30 occurs in a few ms. When an arc is detected, the resistance presented by the RA30 drops to a level where the current flow increases to approxi-

mately 20mA. This increased current flow is detected by the RA23 Module which responds in <1 ms to close a solid state contact to activate the arc fault input on the protection relay as depicted in figures 6 and 7.

### Arc Sensor supervision

The RA30 Arc Sensor is the heart of the system and supervision of the circuit continuity is critical for correct operation. To monitor the integrity of the wiring between the RA30 arc sensor and the RA23 Module, a continuous 2mA supervision current flows between the units. A supervision healthy signal is output to the protection relay status input. This signal will be disabled after an ~1s time delay if the supervision current signal is lost.

An arc sensor fault will also be reported if an incorrect number of sensors are fitted to the RA23 Module as follows:

No arc sensor(s) connected

1 sensor connected to an RA23 Module specified for 2 sensors

### Arc sensor fault indication;

Where a fault is detected on the Arc Sensor circuit the front panel power LED will flash continuously until the fault is rectified.

### Arc fault tripping using current check

Fast operation of a tripping scheme usually results in reduced system security. The arc detection method can however, combine the optical detection technique with a traditional overcurrent method to maximize system security. Both conditions must coexist for the trip condition to be met as depicted in figures 6 - 7.

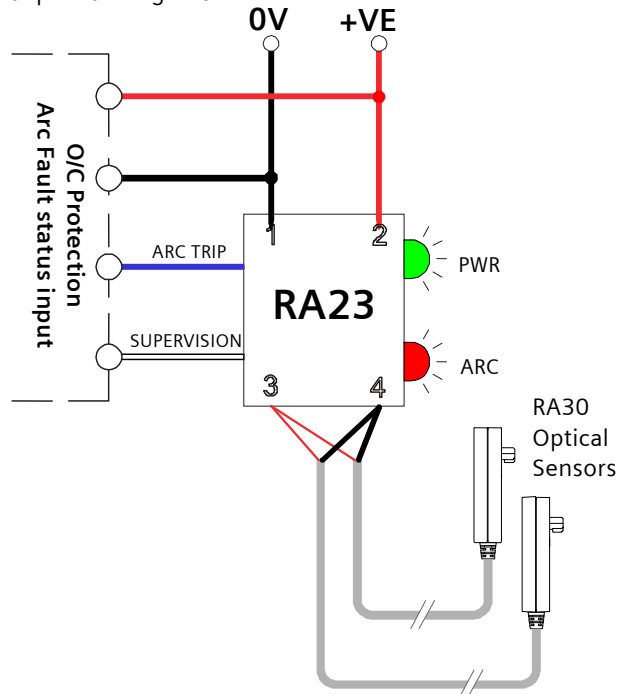

Figure 5: Key components required to implement an Arc fault Protection scheme with an overcurrent check stage to enhance system security

The application examples in figures 1 and 2 utilize this concept for enhanced system security in that both the RA23 Module AND the OC 50 starter logic must be picked up for a CB trip signal to be initiated. As the arc fault trip contact picks up considerably faster than the overcurrent relay starter element, the CB trip time will be dictated by the overcurrent relay performance.

# Relay Logic & Wiring

## Protection relay logic

For the current check scheme to function correctly a protection relay with the following attributes is required:

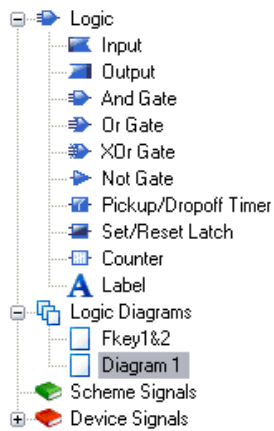

Attribute	Parameter	Necessity
Programmable relay logic	AND gates	Mandatory
High speed status input	<5ms pick up	Mandatory
High speed current check element	<15ms at 2x setting	Mandatory
Programmable front panel indication	Arc trip indication	Desirable
	Supervision status	Desirable
IEC61850 for trip signaling	GOOSE messaging	Optional

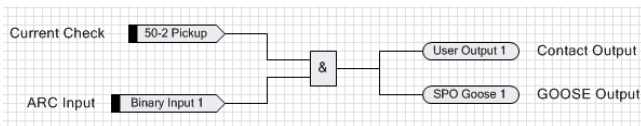

Figure 6: Reydisp manager logic programming

A suitable relay available with all of the above attributes is the Reyrolle 7SR21/22 platform multi-function feeder manager. A screen shot of the Reydisp Manager logic programming software is shown in figure 6.

# Relay Logic & Wiring

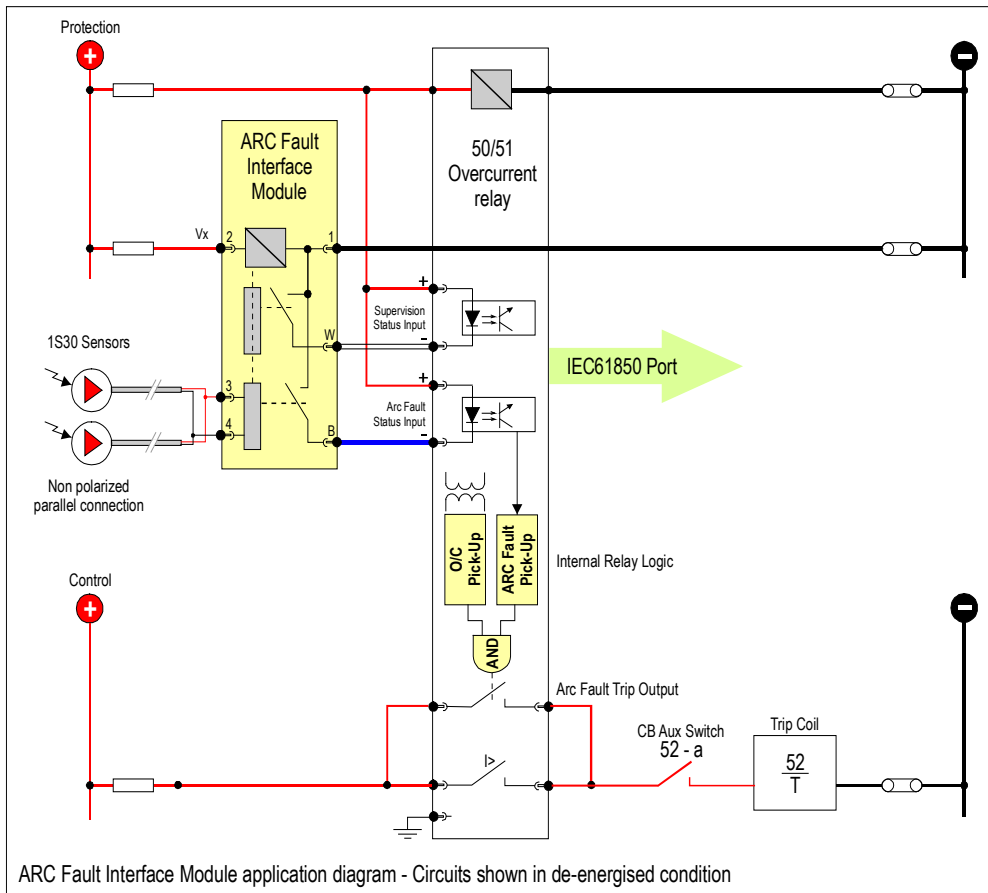

Figure 7: RA23 Module application diagram

# Relay Logic & Wiring

## Enclosure dimensions

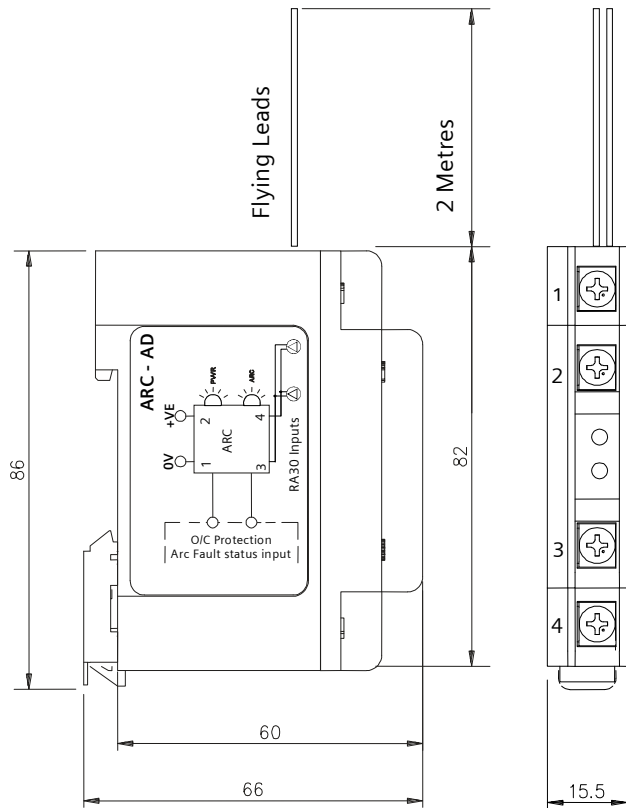

Figure 8: RA23 Module dimensional details

## Arc Sensor inputs

One or two optical arc fault sensors type RA30 may be connected to the RA23 Module. [Refer to the RA30 Catalogue Sheet](#) for mounting options.

The number of sensors specified in the RA23 ordering code must be connected to ensure correct operation of the sensor supervision function.

If only one sensor is connected to the two sensor version the supervision output will indicate a sensor fail condition.

If two sensors are connected to the one sensor version the supervision output will indicate a sensor fail condition.



Figure 9: RA30 Arc Fault Sensor – front and back

## DIN rail mount enclosure

The ARC Fault Interface Module is enclosed in a compact enclosure sealed with thermally conductive potting compound. The module is designed for DIN rail mounting.



Figure 10: RA23 Module depicting four (4) front screw terminals and two (2) top entry flying leads

## Terminations

4x M4 screw terminals suitable for heavy duty ring lugs.

Terminal 1: DC negative

Terminal 2: DC positive

Terminal 3: RA30 arc fault in (Non polarized)

Terminal 4: RA30 arc fault in (Non polarized)

2x 2 metre flying leads with 0.75 sq. mm conductor.

Blue lead: Arc fault trip output - negative

White lead: Supervision status output - negative

## Mounting

DIN rail mounting of multiple DIN rail modules allows for a compact installation close to the protection relay status inputs. Wiring should be kept as short as practical to minimize the circuit resistance and possibility of noise on the protection relay status input.

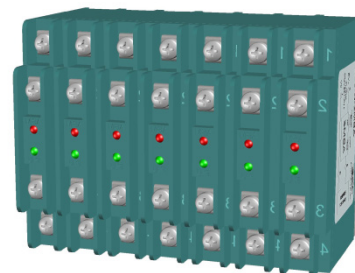

Figure 11: Array of 7 x RA23 modules

## Optical sensitivity

~10,000 Lux\* for white light at normal incidence to the detector window(s) as depicted in figure 12:

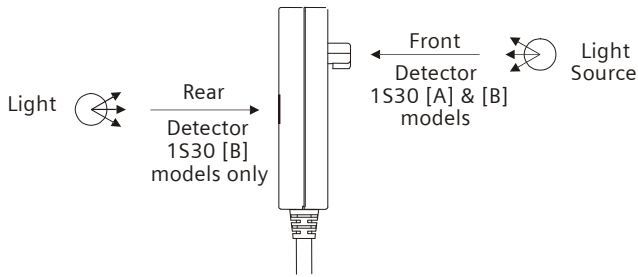

Figure 12: RA30 Arc Sensor

As the illuminance of diffuse ambient sunlight falls in the range 5,000 to 10,000 Lux, this will not normally be sufficient to trigger the RA23 Module. The luminous intensity from the sun at noon at the equator however is ~100,000 Lux which will be sufficient to trigger the RA23 Module so measures should be made to avoid this situation.

## Detector spectral response

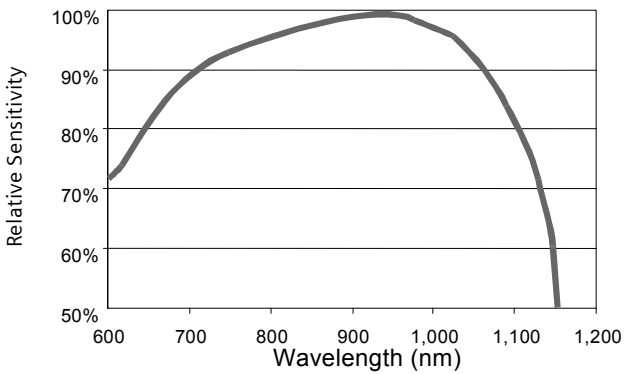

Figure 13: Arc detector spectral response

\* Due to the relatively high sensitivity of the detector to IR wavelengths the type of light source employed for sensitivity testing will have a major effect on the results obtained. Sensitivity testing should therefore be conducted using a 50-75W halogen lamp with an integrated aluminum reflector.

## System supervision

A CPU software watchdog monitors the system and in the event of an abnormal condition will automatically perform a soft restart.

Should this restart not clear the abnormal condition the system will revert to a safe mode with the outputs disabled. This will cause the self supervision healthy signal to be lost and the abnormal condition detected and reported by the protection relay via its ARC supervision status input. A front panel green LED is illuminated on the RA23 Module under normal conditions. This LED is switched off in safe mode.

## Minimum Arc duration

The minimum arc "flash" duration required to guarantee operation of the output contacts is 0.5ms.

## Trip signal reset time

Once operated the trip output signal is self reset with a minimum dwell time of 100 to 120ms.



## Technical Data

### Auxiliary supply burden (At 110V DC)

Monitoring mode:	Less than 0.75W
Arc fault detected:	Less than 1.5W for 2s

### Auxiliary supply

The Arc Module is suitable for use with the following nominal auxiliary supplies. A tolerance of -20% to +20% must be maintained to ensure correct operation and to avoid thermal damage.

Vx
24V DC
32V DC
48V DC
110V DC
125V DC
220V DC
240V DC
250V DC

### Optical Arc fault detection operate time

An arc fault trip signal is output in less than 1ms.

### Output circuit

Dedicated non-isolated outputs are provided to connect to overcurrent protection relay status inputs as shown in figure 6. Upon detection of light intensity greater than the pick-up threshold a solid state switch connects the 0V rail to the relay status input.

### Output ratings IEC60255-0-2

The Arc Module outputs are designed for connection to dedicated protection class binary status inputs only. They are not suitable for direct tripping applications of auxiliary relays or circuit breaker coils.

The following ratings are conservative and are suitable for application with status inputs employed on many modern protection relays such as the Reyrolle 7SR1 and 7SR2 platforms.

### Supervision output

Open circuit voltage:	125% of nominal
Maximum current:	15mA for 20 ms 4mA continuous

### Arc trip output

Open circuit voltage:	125% of nominal
Maximum current:	15mA for 20 ms 4mA continuous

### Auxiliary supply IEC60255-11

Allowable breaks / dips in supply Collapse to zero from nominal voltage	≤ 20ms
--	--------

### High Frequency disturbance IEC60255-22-1 Class III

2.5kV 1MHz common mode 1.0kV 1MHz differential mode	No mal operation
--	------------------

### Electrostatic discharge IEC60255-22-2 Class III

8kV air discharge	No mal operation
-------------------	------------------

### Radio frequency interference IEC60255-22-3

10V/m, 80 TO 1,000MHz	No mal operation
-----------------------	------------------

### Fast transient IEC60255-22-4

4kV, 5/50ns, 100KHz repetitive	No mal operation
--------------------------------	------------------

### Insulation coordination IEC60255-5

Impulse voltage withstand test Dielectric test	5kV 1.2/50us 0.5J 2.0kV RMS for 1 minute
---	---

Between all terminals and earth  
The earth point is defined as the DIN rail mounting bracket  
There is no isolation between any of the output terminals or flying leads. They should be considered as the same group.

### Conducted RFI IEC60255-22-6

10V, 0.15 to 80MHz	No mal operation
--------------------	------------------

### Temperature range IEC68-2-1/2

Operating:	-10 to +55°C
Storage:	-25 to +75°C

### Humidity IEC68-2-78

40 °C and 93% RH non condensing

## Technical Data (Contd)

Fault Condition	RED LED	Trip Output	GREEN LED	Supervise Output
One (1) Sensor open circuit	OFF	OFF	FLASH	OFF
Two (2) Sensors open circuit	OFF	OFF	FLASH	OFF
One (1) Sensor short circuit on power up	OFF	OFF	FLASH	OFF
Two (2) Sensors short circuit on power up	OFF	OFF	FLASH	OFF
Arc trip >500ms (Continuous arc pick up)	ON	OFF	FLASH	OFF
Arc trip current limit exceeded	ON for 2s	OFF for 100ms	OFF for 2s	OFF for 2s
Supervise output current limit exceeded	OFF	OFF	FLASH - PAUSE - FLASH	OFF
Power supply fail	OFF	OFF	OFF	OFF
CPU fail	OFF	OFF	OFF	OFF
Single sensor software identification			Three (3) flashes at startup	
Dual sensor software identification			Four (4) flashes at startup	

Figure 14: Arc Module status table

# Ordering Information

Product description	Variants	Order No.
Reyarc – Arc Fault Protection Components	<u>Category</u> Arc Protection  <u>Device</u> RA23 Arc Fault Interface Module  <u>Sensor Inputs</u> One sensor input Two sensor inputs  <u>Operating Voltage</u> 24V DC 32V DC 48V DC 110V DC 125V DC 220V DC 240V DC 250V DC	7 X G 3 1 2 3 - □ □ A 0 0 - 0 A A 0 ↑ ↑ ↑ ↑ ↑ ↑ ↑ ↑ 3 1 2 3 1 2 A B C D E F G H

Siemens Protection Devices Limited  
P.O. Box 8  
North Farm Road  
Hebburn  
Tyne & Wear  
NE31 1TZ  
United Kingdom  
Phone: +44 (0)191 401 7901  
Fax: +44 (0)191 401 5575  
E-mail: [marketing.spdl.gb@siemens.com](mailto:marketing.spdl.gb@siemens.com)

EMEA-C10067-00-76GB

April 2015

For enquires please contact our Customer Support Center  
Phone: +49 180/524 8437 (24hrs)  
Fax: +49 180/524 24 71  
E-mail: [support.ic@siemens.com](mailto:support.ic@siemens.com)  
[www.siemens.com/protection](http://www.siemens.com/protection)

Printed on elementary chlorine-free bleached paper.

[www.siemens.com/energy](http://www.siemens.com/energy)