

IF IN DOUBT ASK
DO NOT SCALE

NOTES
 1 FOR R4 BOX ASSY SEE 2434H10004 (A1)
 2 TERMINALS RECOMMENDED ARE PRE INSULATED & MUST BE CRIMPED USING APPROVED TOOLING. AMP PIDG OR PLASTI GRIP FUNNEL ENTRY (RING TONGUE) FOR M4 FIXING STUD.

SUPPLIER	AMP	CABLE SIZE
AMP	342103	0.25-1.6 SQ MM
AMP	342143	1.0-2.6 SQ MM.

OR ANY OTHER MANUFACTURERS EQUIVALENT TERMINAL.

3 FOR OUTLINE & DRILLING DRG SEE 2434X10001 (A4).
 4 PROTECTIVE CAPS TAKEN FROM FIBRE OPTIC CONNECTORS MAY BE RETAINED ON COMMS INTERFACE FIXING NUTS.

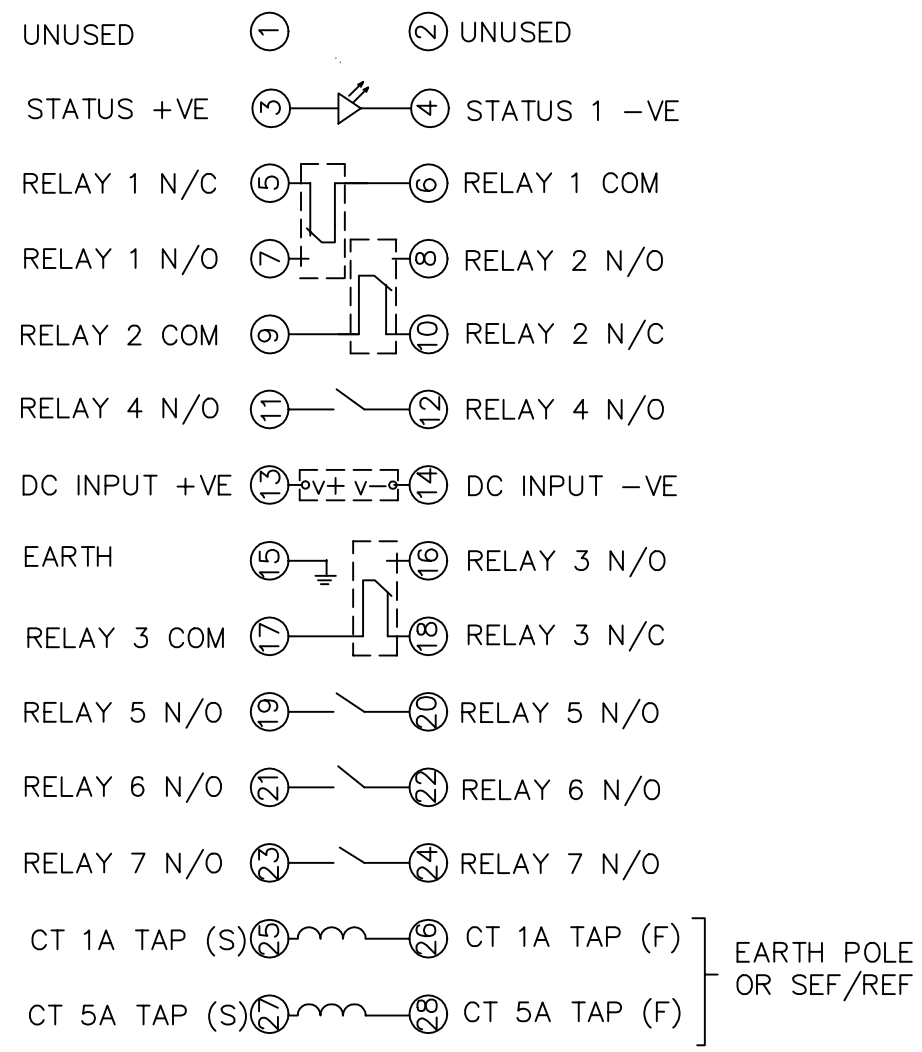
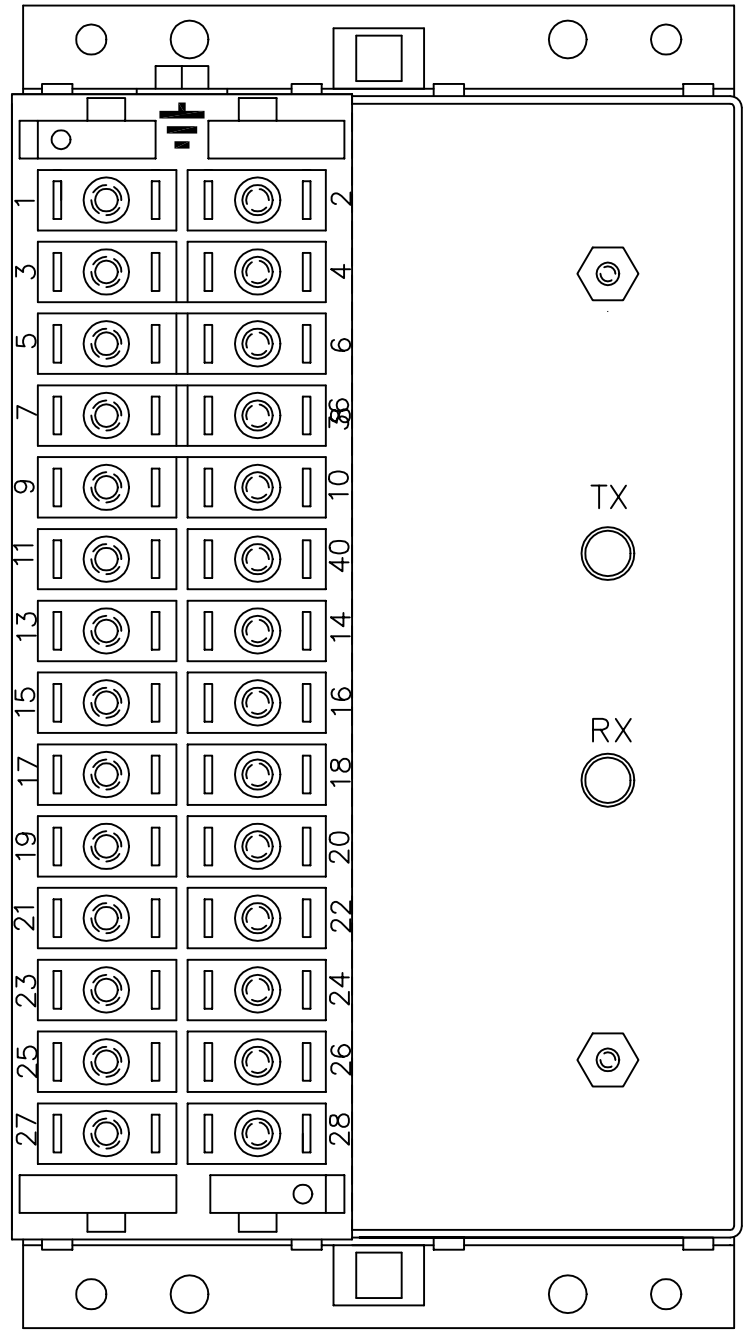

BOX VIEWED FROM REAR

**NOT SUBJECT TO UPDATE
ONCE COPIED / PRINTED
OR DOWNLOADED**

MATERIAL:

Dimensions in millimetres ; Surface texture in micrometres.
 Machine where marked ✓
 For explanation of dimensions, tolerances, notes etc. see B.S.308.
 Limit on untoleranced unmachined dimensions ± _____
 Limits on untoleranced machined dimensions to B.S.4500;
 i.e. up to 6±0.1; over 30 to 120±0.3; over 315±0.8;
 over 6 to 30±0.2; over 120 to 315±0.5;
 General unmachined angular tolerance ± _____

Finish: _____
 Treatment: _____

Title:
 TERMINAL IDENTIFICATION & RELAY
 WIRING DIAGRAM SINGLE POLE DCD RELAY

**Reyrolle Protection
 Hebburn.**

Original Scale:
 1:1

First used on: _____
 Similar Articles: _____
 Supersedes: _____
 Drg. No. **2434W10002**

1	30/11/95	CHANGE NOTED	△
ISSUE	DATE	NOTED	

Copyright © Reyrolle Ltd.