

IF IN DOUBT ASK
DO NOT SCALE

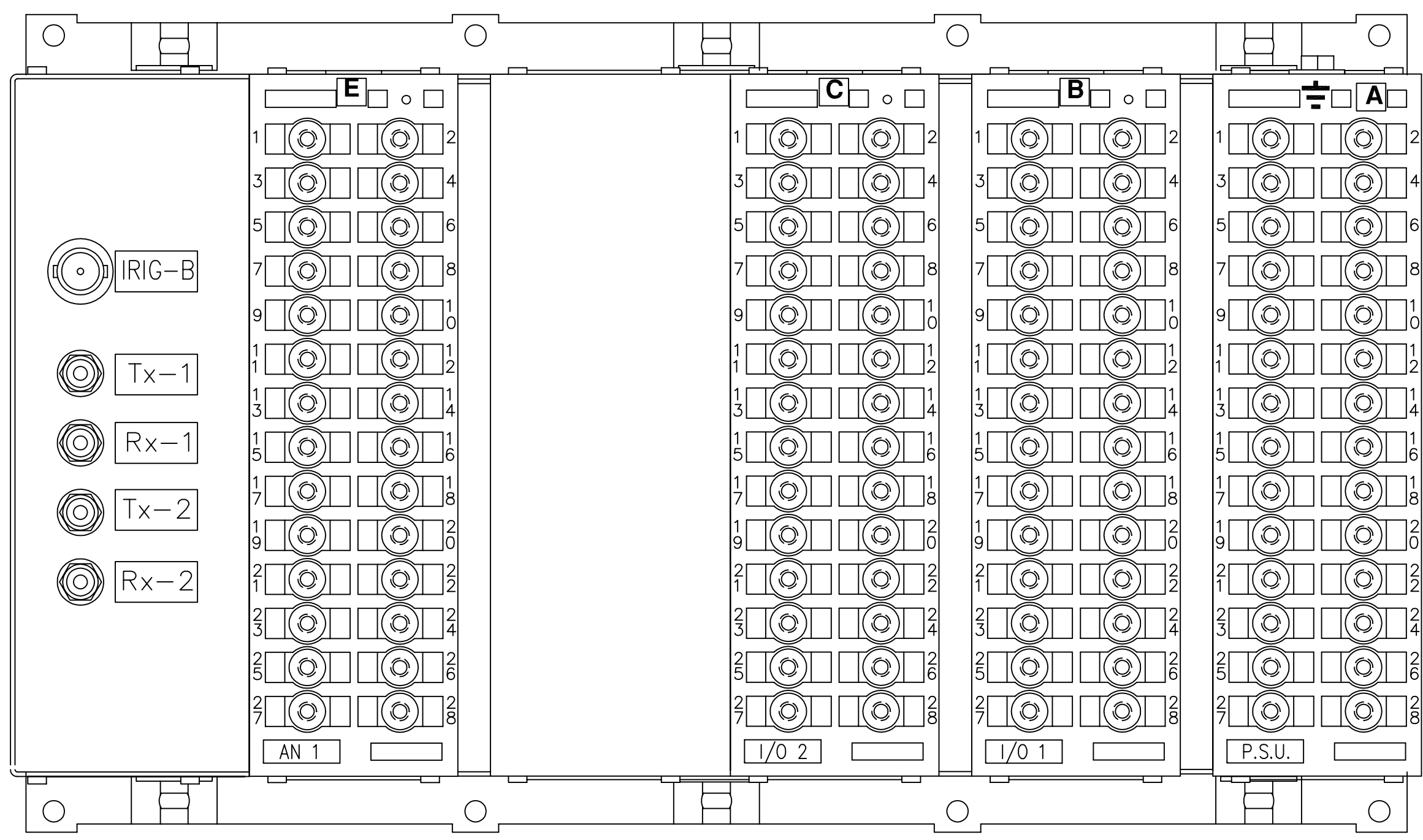

RELAY VIEWED FROM REAR

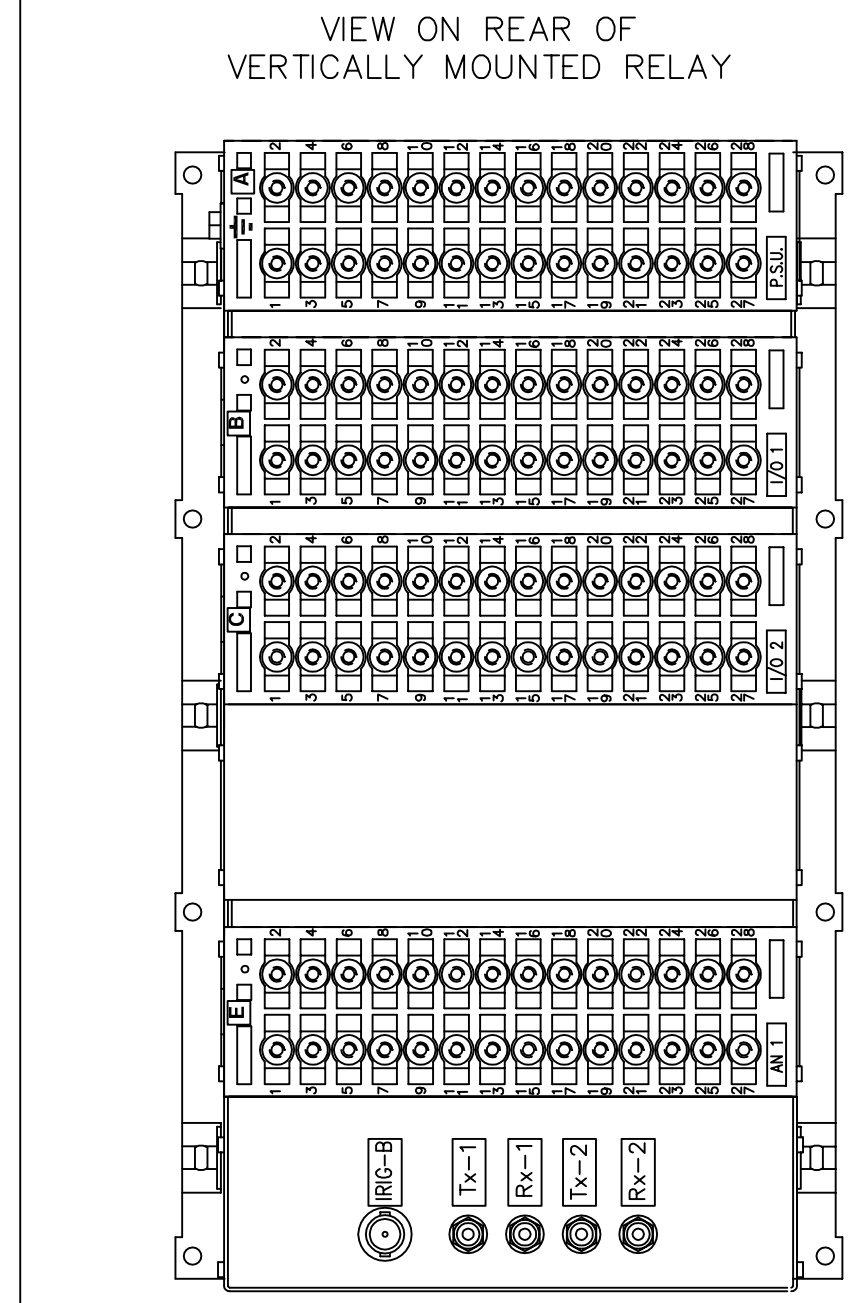

NOTES

1 TERMINALS RECOMMENDED ARE PRE INSULATED & MUST BE CRIMPED USING APPROVED TOOLING.
AMP PIDG OR PLASTI GRIP FUNNEL ENTRY (RING TONGUE) FOR M4 FIXING STUD.

SUPPLIER	AMP	CABLE SIZE
AMP	342103	0.25-1.6 SQ MM
AMP	342143	1.0-2.6 SQ MM.

OR ANY OTHER MANUFACTURERS EQUIVALENT TERMINAL.

2 FOR OUTLINE & DRILLING DRG SEE 2995X10012 (A4).
3 IRIG-B & FIBRE OPTIC CONNECTORS MUST BE DISCONNECTED & FIXING NUTS REMOVED BEFORE WITHDRAWING CONTROLLER MODULE.

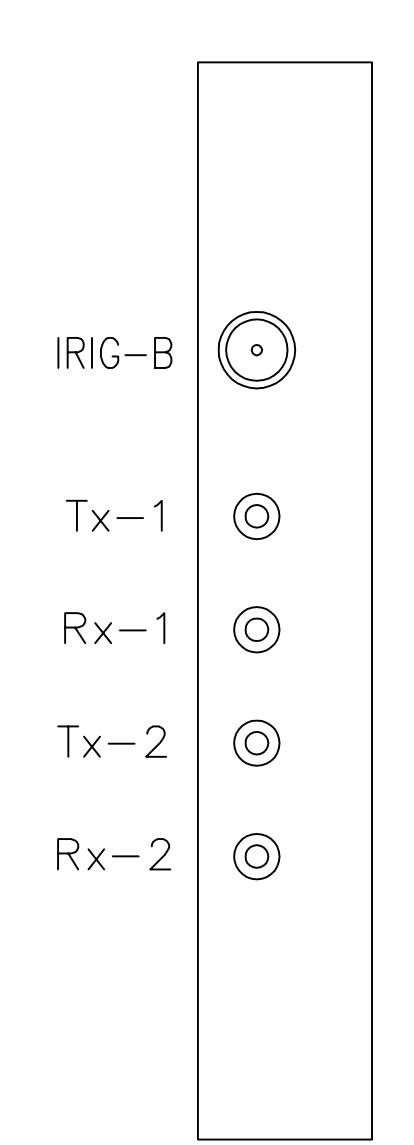

Controller Module
(SEE NOTE 3)

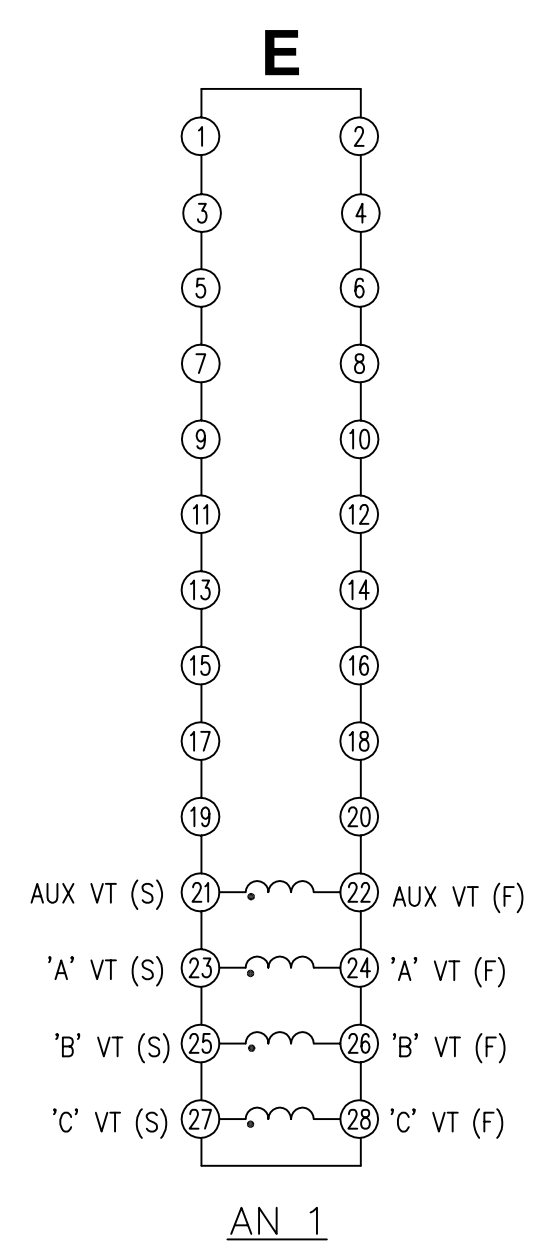

AN 1

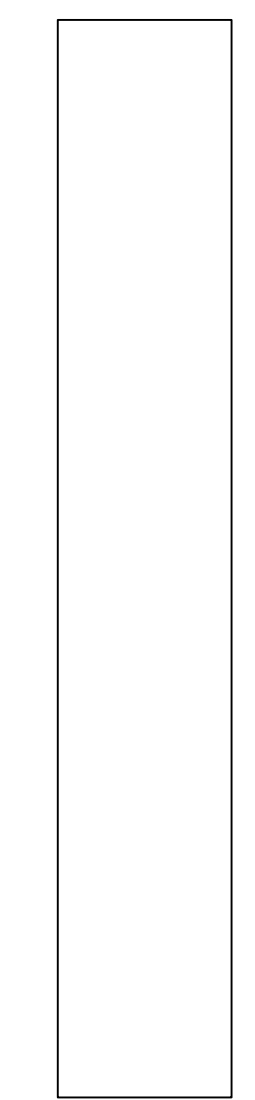

No Module Fitted

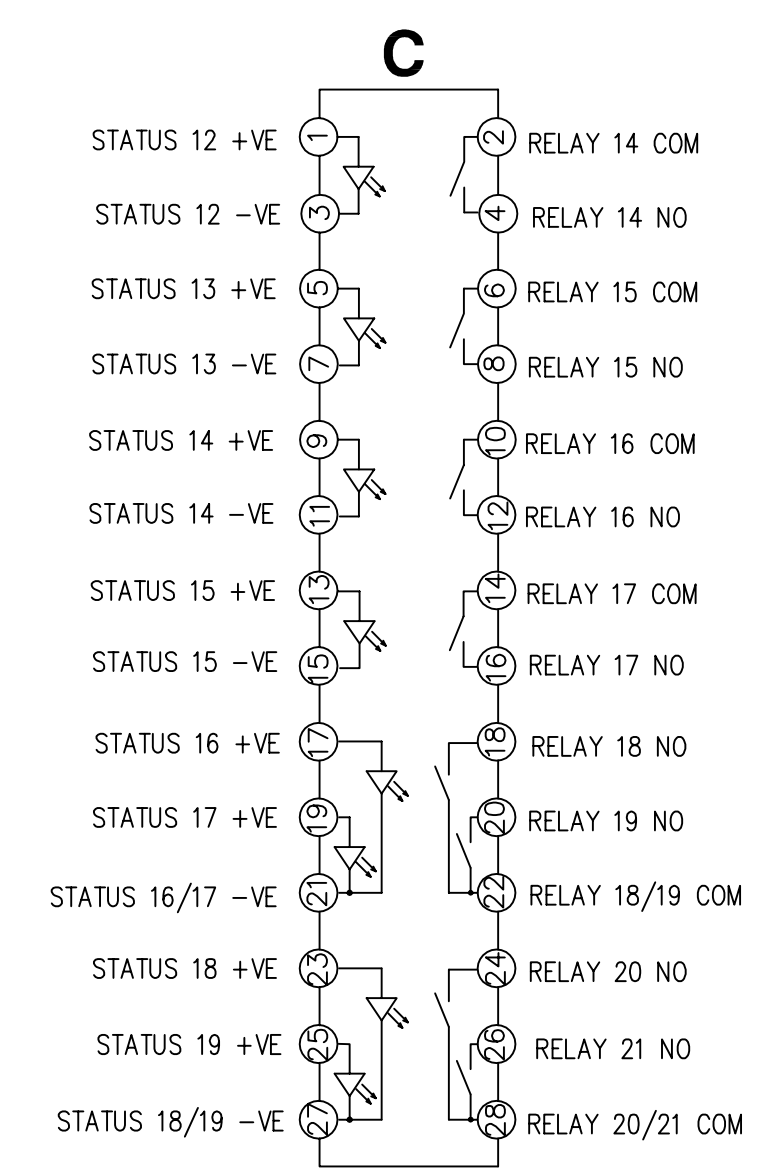

I/O 2

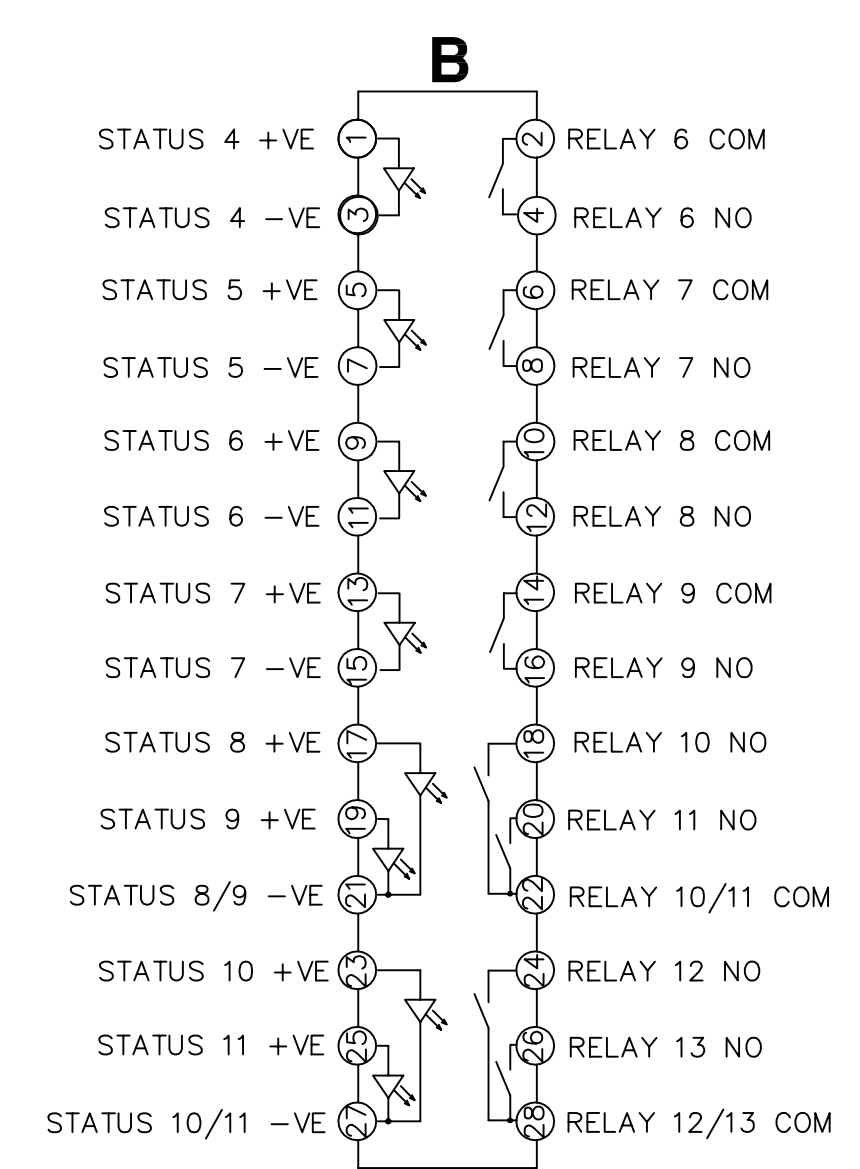

I/O 1

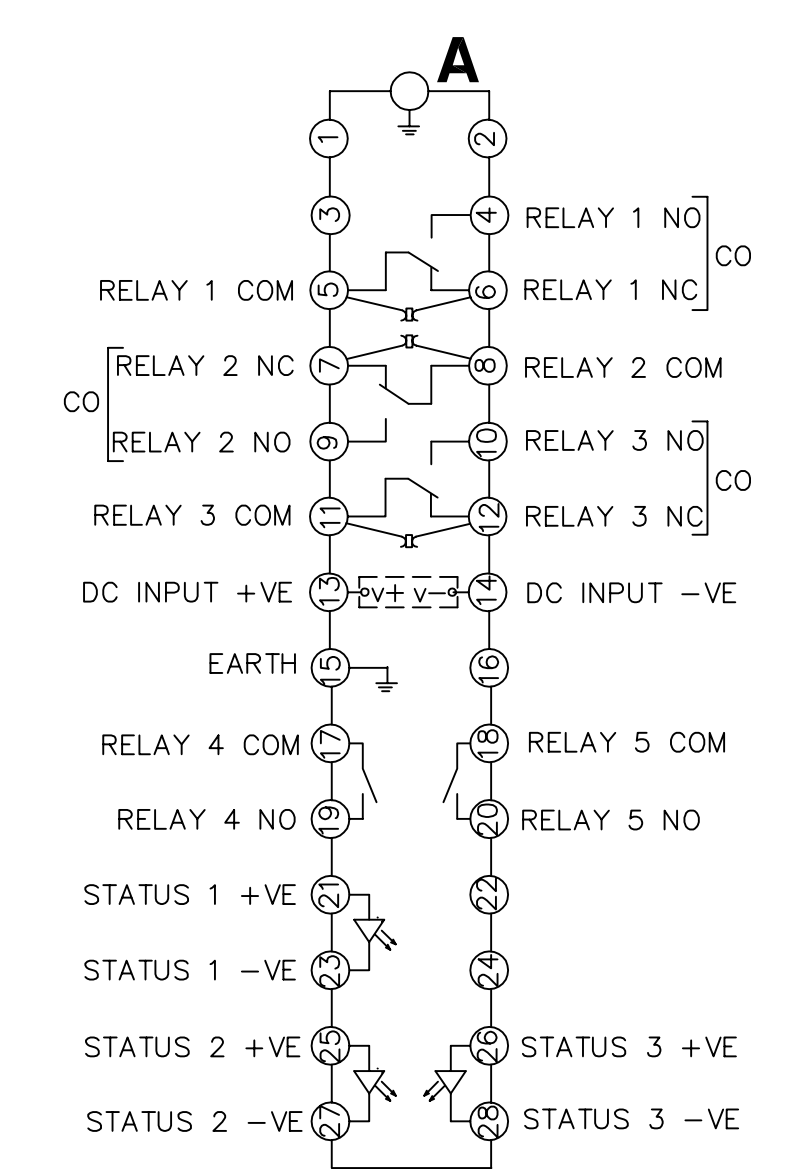

P.S.U.

MODULE LABEL KEY	
ANALOGUE MODULE	AN 1 etc
INPUT/OUTPUT MODULE	I/O 1 etc
P.S.U. & BASIC I/O MODULE	P.S.U.

ABBREVIATIONS	
CT	CURRENT INPUTS
VT	VOLTAGE INPUTS
SI	STATUS INPUTS
CO	CHANGE OVER OUTPUT CONTACTS
NO	NORMALLY OPEN OUTPUT CONTACTS
NC	NORMALLY CLOSED OUTPUT CONTACTS

MATERIAL:

Dimensions in millimetres ; Surface texture in micrometres.
Machine where marked ✓
For explanation of dimensions, tolerances, notes etc. see B.S.308.
Limit on untoleranced unmachined dimensions ±
Limits on untoleranced machined dimensions to B.S.4500;
i.e. up to 6±0.1; over 30 to 120±0.3; over 315±0.8;
over 6 to 30±0.2; over 120 to 315±0.5;
General unmachined angular tolerance ±

Finish:
Treatment:

Title:
TERMINAL I.D. & WIRING FOR IOA 201 SERIES RELAY
(4VT,19SI,3CO,18NO) E12 CASE.
VATECH REYROLLE
AUTOMATION, CONTROL & PROTECTION

Original Scale:
NTS

Dr. No.
2761W11019

FOR INFORMATION ONLY
UNCONTROLLED COPY
NOT SUBJECT TO UPDATE

Copyright © 2004 VATECH REYROLLE ACP Ltd. Hebburn