

IF IN DOUBT ASK
DO NOT SCALE

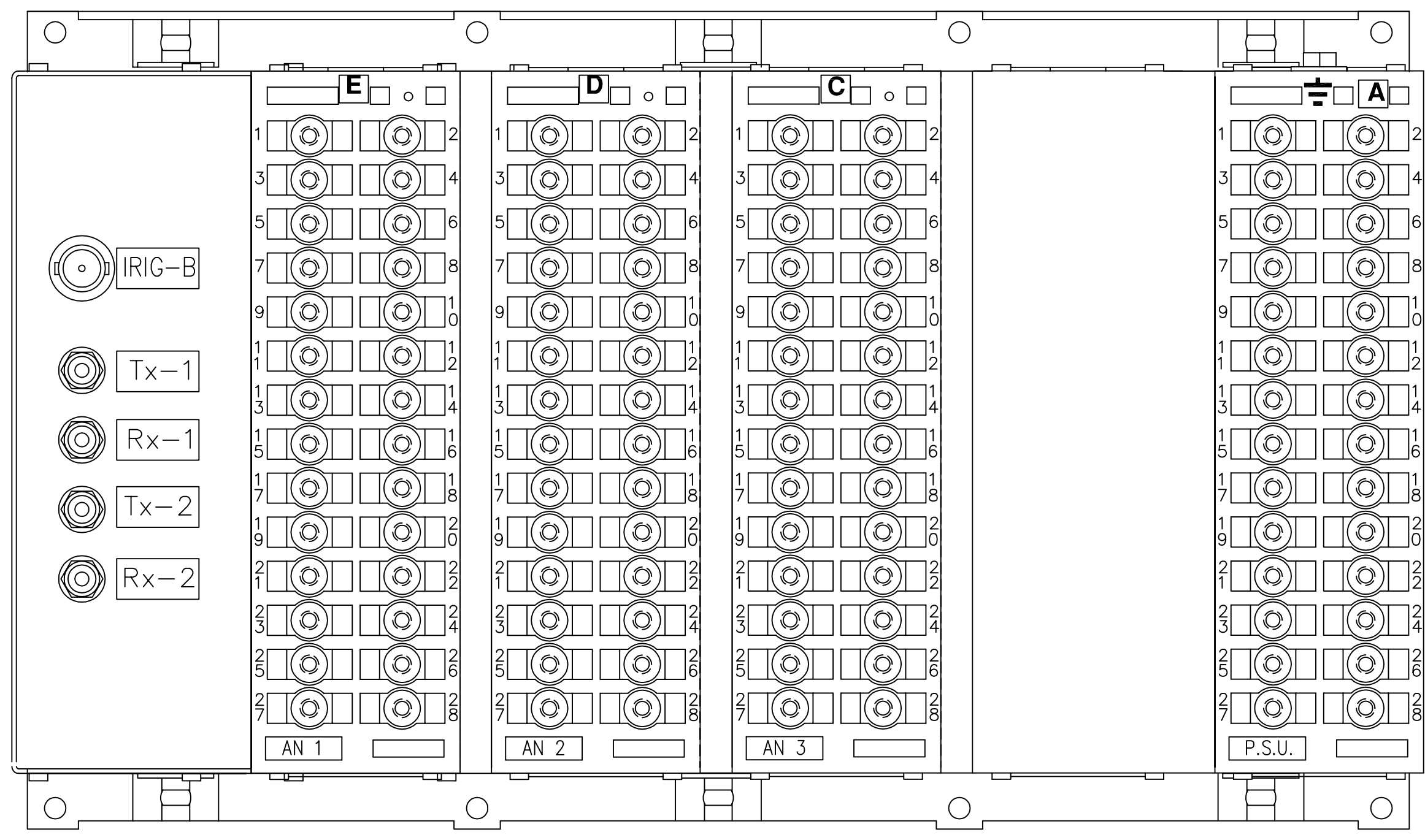

RELAY VIEWED FROM REAR

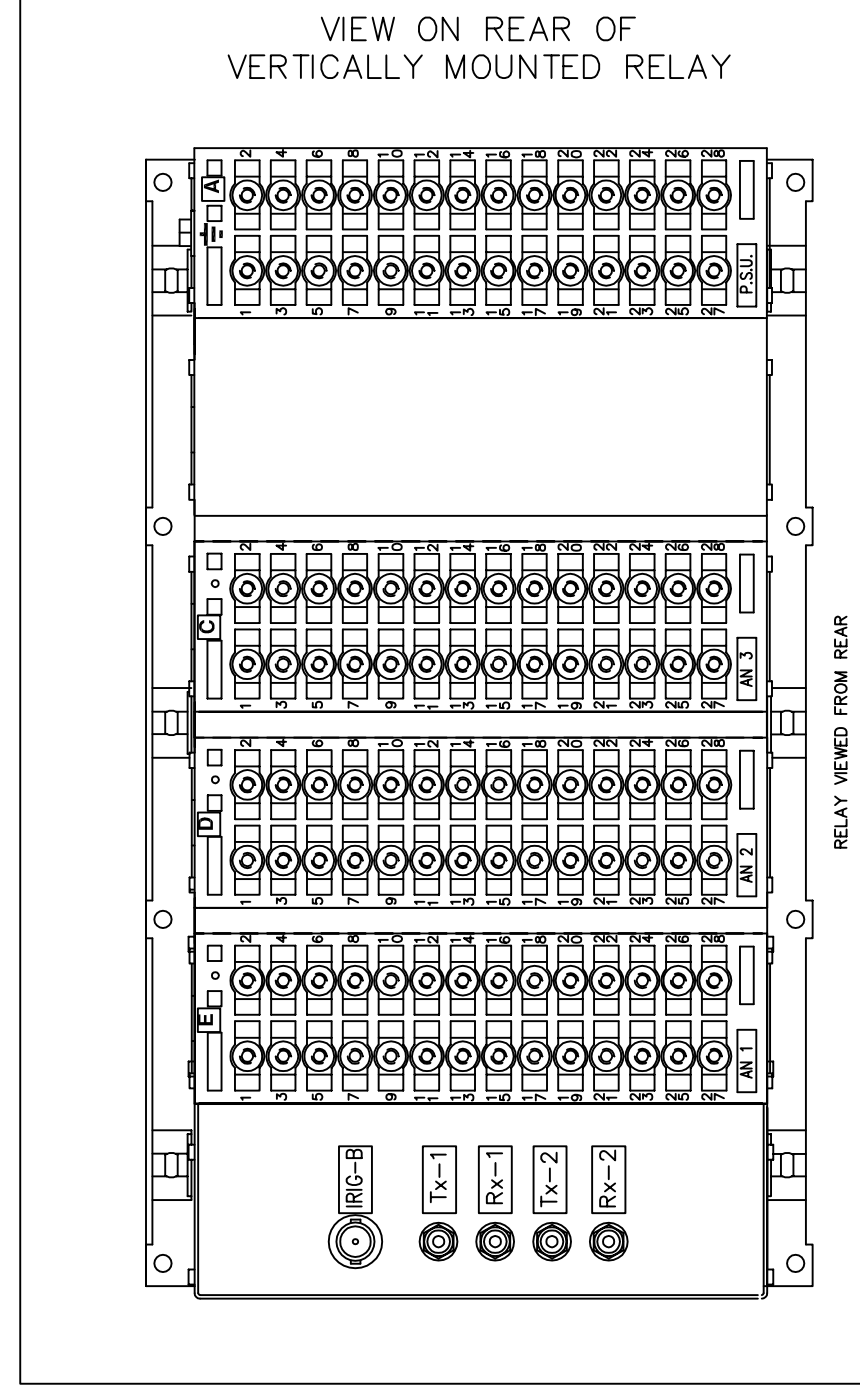

NOTES

1 TERMINALS RECOMMENDED ARE PRE INSULATED & MUST BE CRIMPED USING APPROVED TOOLING. AMP PIDG OR PLASTI GRIP FUNNEL ENTRY (RING TONGUE) FOR M4 FIXING STUD.

SUPPLIER	AMP	CABLE SIZE
AMP	342103	0.25-1.6 SQ MM
AMP	342143	1.0-2.6 SQ MM.

OR ANY OTHER MANUFACTURERS EQUIVALENT TERMINAL.

2 FOR OUTLINE & DRILLING DRG SEE 2995X10012 (A4).

3 IRIG-B & FIBRE OPTIC CONNECTORS MUST BE DISCONNECTED & FIXING NUTS REMOVED BEFORE WITHDRAWING CONTROLLER MODULE.

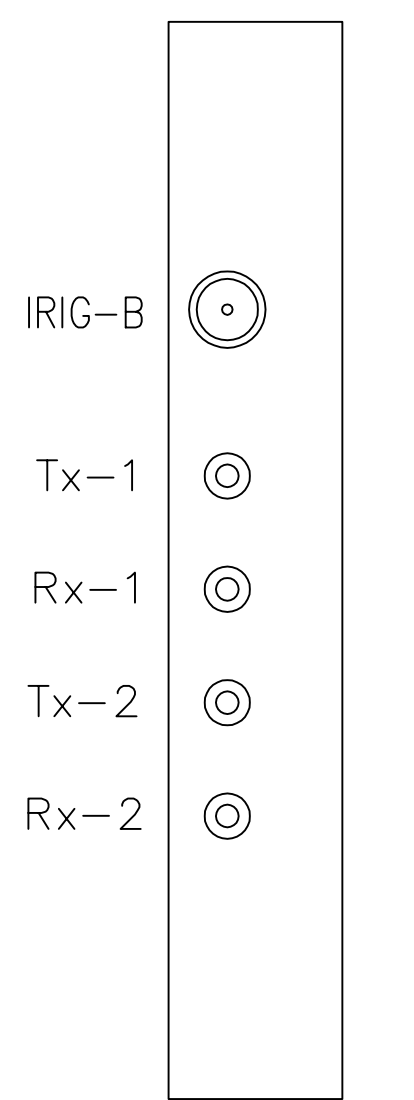

Controller Module
(SEE NOTE 3)

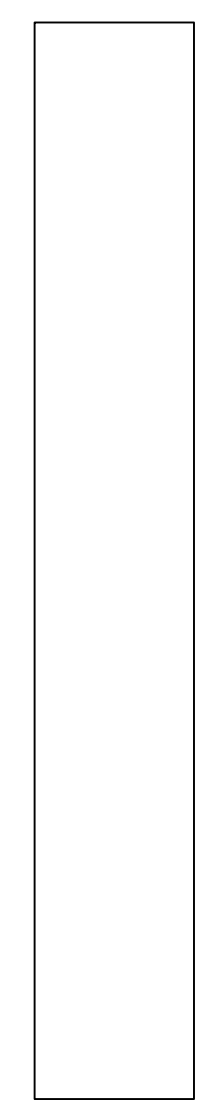
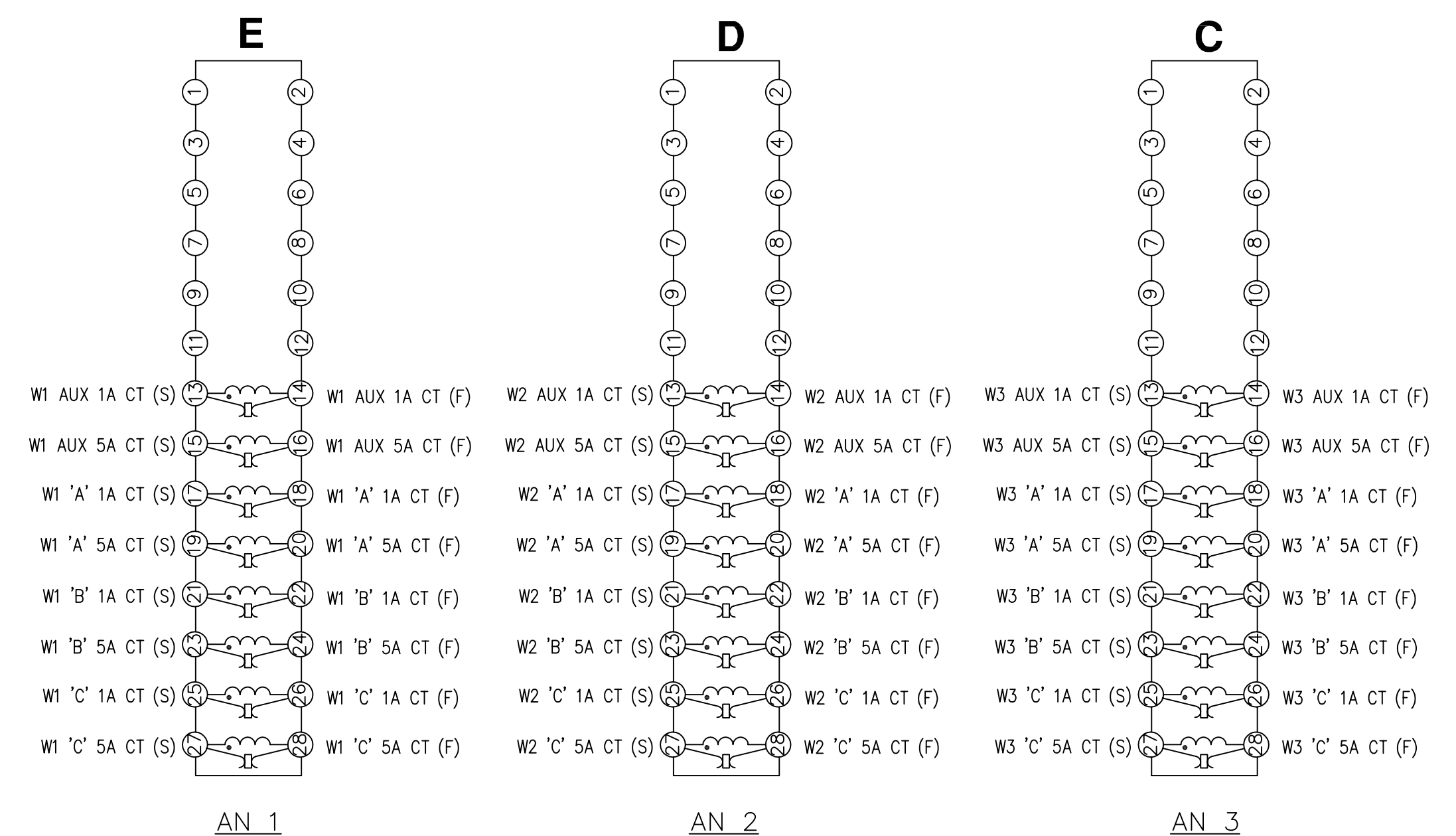

No Module Fitted

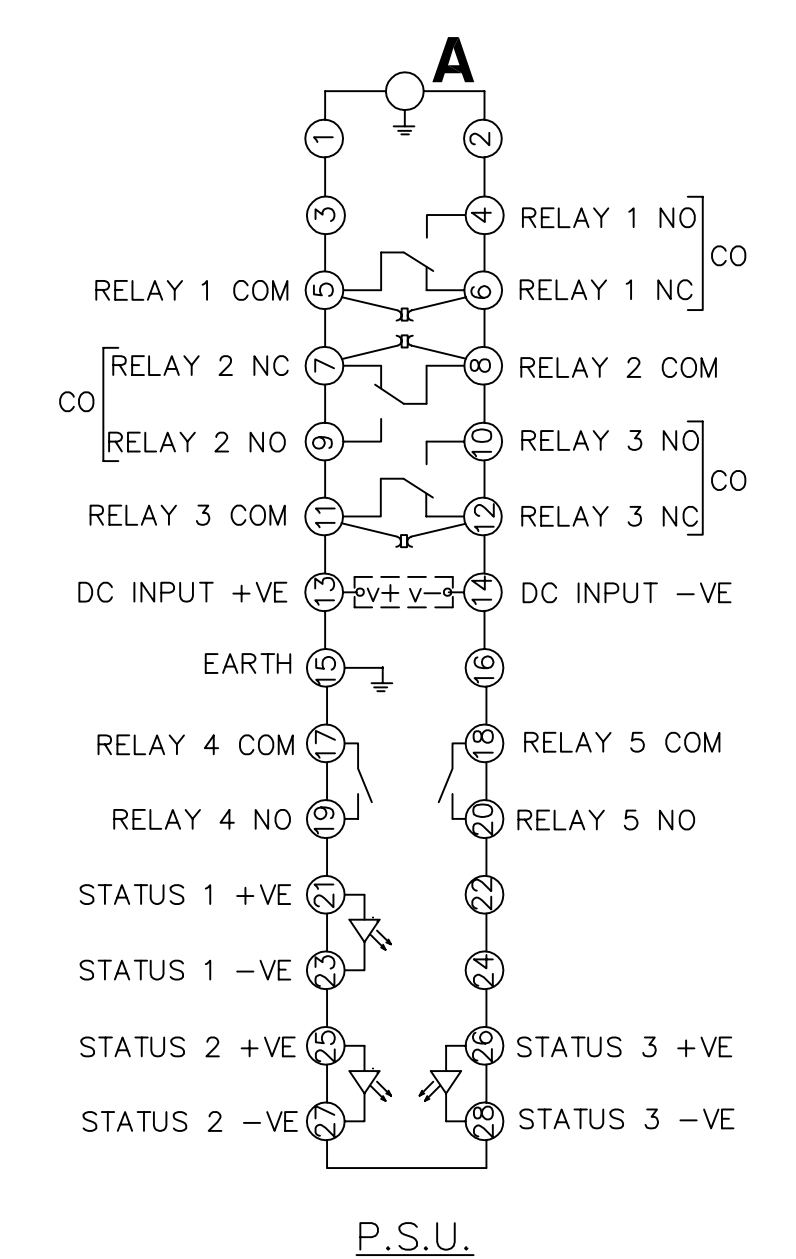

P.S.U.

MODULE LABEL KEY	
ANALOGUE MODULE	AN 1 etc
INPUT/OUTPUT MODULE	I/O 1 etc
P.S.U. & BASIC I/O MODULE	P.S.U.

ABBREVIATIONS	
CT	CURRENT INPUTS
VT	VOLTAGE INPUTS
SI	STATUS INPUTS
CO	CHANGE OVER OUTPUT CONTACTS
NO	NORMALLY OPEN OUTPUT CONTACTS
NC	NORMALLY CLOSED OUTPUT CONTACTS

FOR INFORMATION ONLY
UNCONTROLLED COPY
NOT SUBJECT TO UPDATE

MATERIAL:

Dimensions in millimetres ; Surface texture in micrometres.
Machining where marked ✓
For explanation of dimensions, tolerances, notes etc. see B.S.308.
Limit on untoleranced unmachined dimensions ±
Limits on untoleranced machined dimensions to B.S.4500;
i.e. up to 6±0.1; over 30 to 120±0.3; over 315±0.8;
over 6 to 30±0.2; over 120 to 315±0.5;
General unmachined angular tolerance ±

Finish:
Treatment:

Title:
TERM IDENT & WIRING DIAGRAM FOR MODULAR II PRODUCT
(12CT,3SI,3CO,2NO) E12 CASE

VATECH REYROLLE
AUTOMATION, CONTROL & PROTECTION

Original Scale:
NTS

Dr. No.
2621W11009

Copyright © 2005 VATECH REYROLLE ACP Ltd. Hebburn