

IF IN DOUBT ASK
DO NOT SCALE

ABBREVIATIONS	
I	CURRENT INPUTS
V	VOLTAGE INPUTS
BI	BINARY INPUTS
BO	BINARY OUTPUTS
CO	CHANGE OVER BINARY OUTPUT CONTACTS
NO	NORMALLY OPEN BINARY OUTPUT CONTACTS
NC	NORMALLY CLOSED BINARY OUTPUT CONTACTS

COMMUNICATIONS IDENTIFICATION	
COM1	RS485 (ON BLOCK 'B' TERMINALS 14,16,18 & 20)
COM2	USB TYPE 'B' PORT (ON RELAY FRONT LABEL)
COM3	RS485 (ON REAR COMMS MODULE)

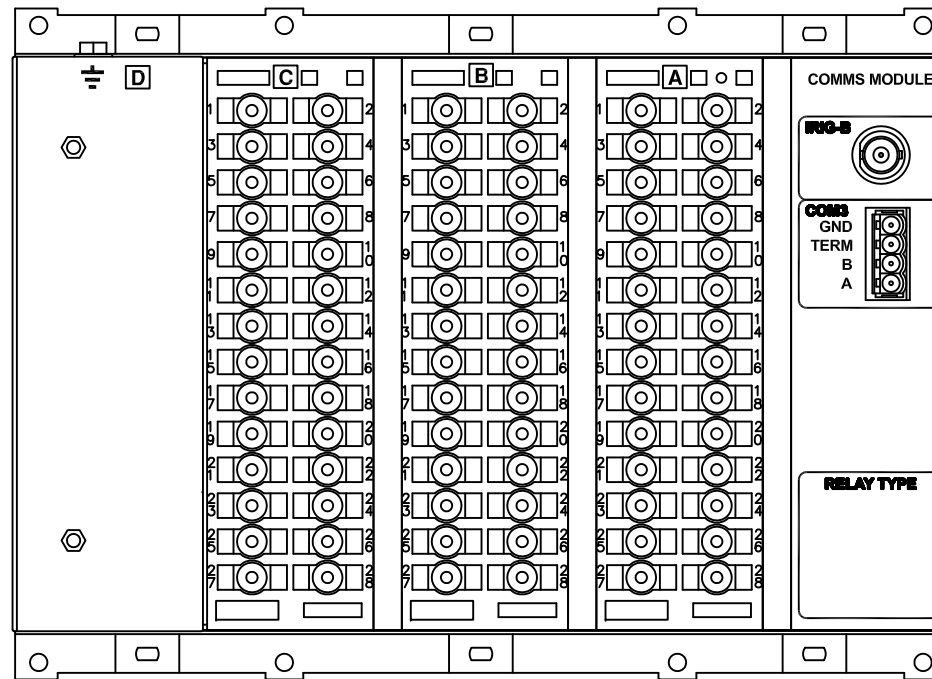

RELAY VIEWED FROM REAR

NOTES

- TERMINALS RECOMMENDED ARE PRE-INSULATED & MUST BE CRIMPED USING APPROVED TOOLING. AMP PIDG OR PLASTI GRIP FUNNEL ENTRY (RING TONGUE) FOR M4 FIXING STUD.
- FOR OUTLINE & PANEL DRILLING, SEE 2995X10010 (A4).
- CONNECTIONS TO THIS COMMUNICATIONS FACILITY IS BY SCREENED, TWISTED PAIR CABLE, ON SITE. WHEN WIRING OTHER FACILITIES ENSURE THAT THESE TERMINALS ARE NOT OBSCURED BY OTHER WIRE RUNS.
- CONTACTS SHOWN THUS ARE INTERNAL RELAY CASE CONTACTS AND CLOSE WHEN THE RELAY CHASSIS IS WITHDRAWN FROM THE CASE.
- THESE CTs ALTHOUGH FITTED ARE NOT ACTIVE IN RECLOSER-M MODELS.

SUPPLIER	PART NUMBER	CABLE SIZE
AMP	342103	0.25-1.6mm ²
AMP	342143	1.0-2.6mm ²

OR ANY OTHER MANUFACTURERS EQUIVALENT TERMINAL.

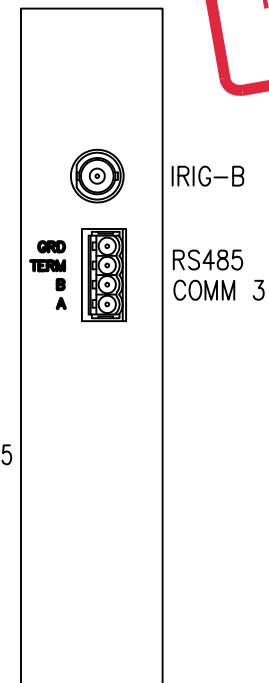
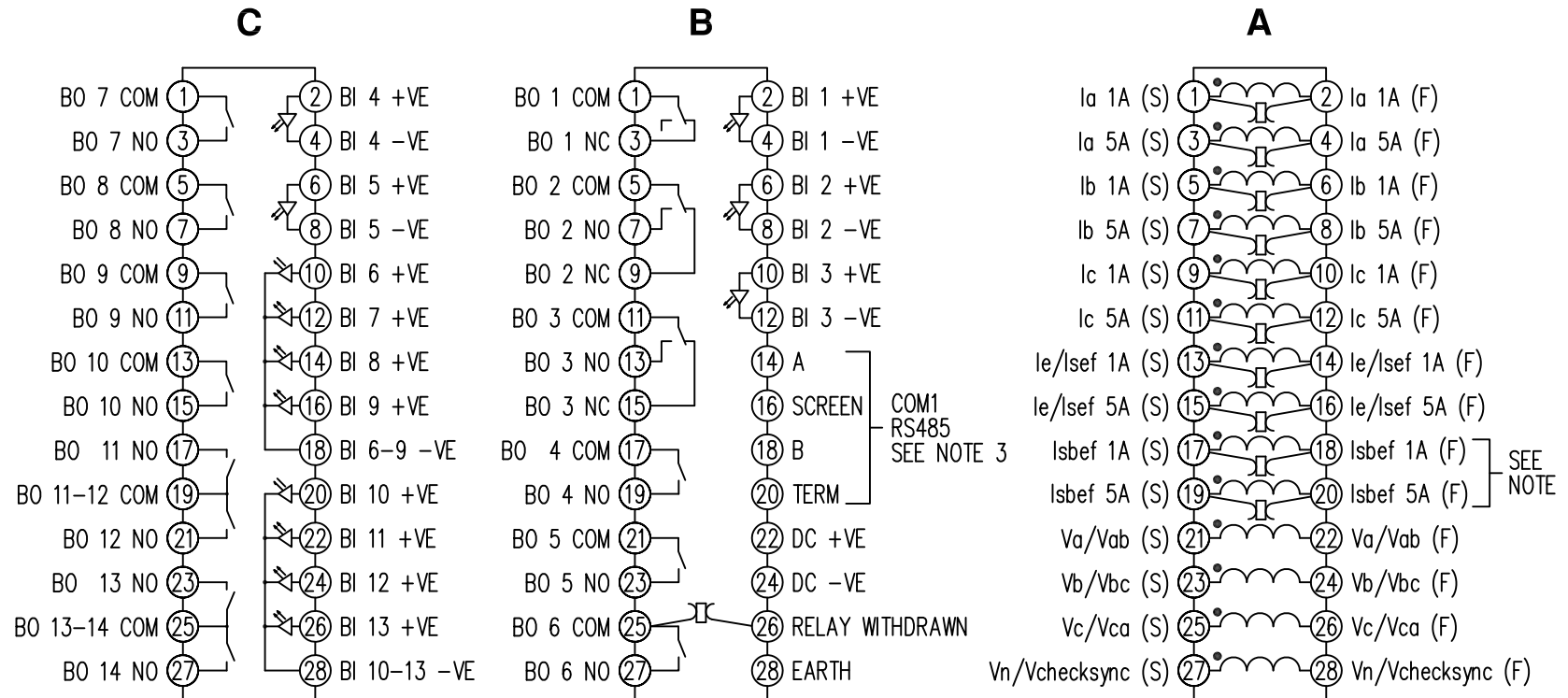
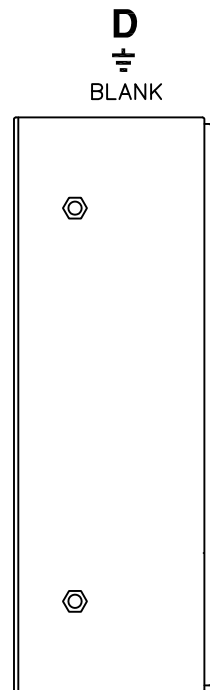

**NOT SUBJECT TO UPDATE
ONCE COPIED / PRINTED
OR DOWNLOADED**

2 RDW	08/09/09	MN435/3175 KB (3HBB_090908)
1	19/05/09	CHANGE
ISSUE	DATE	NOTED

Copyright © 2009 Siemens Protection Devices Ltd. Hebburn

MATERIAL:

Dimensions in millimetres : Surface texture in micrometres.
Machine where marked ✓
For explanation of dimensions, tolerances, notes etc. see B.S.308.
Limit on untoleranced unmachined dimensions ± _____
Limits on untoleranced machined dimensions to B.S.4500;
i.e. up to 6±0.1; over 30 to 120±0.3; over 315±0.8;
over 6 to 30±0.2; over 120 to 315±0.5;
General unmachined angular tolerance ± _____

Finish:

Title:
TERMINAL ID & WIRING DIAGRAM FOR RM PLATFORM
(5I,4V,13BI,2CO,11NO,1NC,RS485(x2)+IRIG-B) E10 CASE

First used on:

Treatment:

SIEMENS PROTECTION DEVICES LTD.

Original Scale.

NTS

Supersedes:

Drq. No.
2435W40033