

IF IN DOUBT ASK
DO NOT SCALE

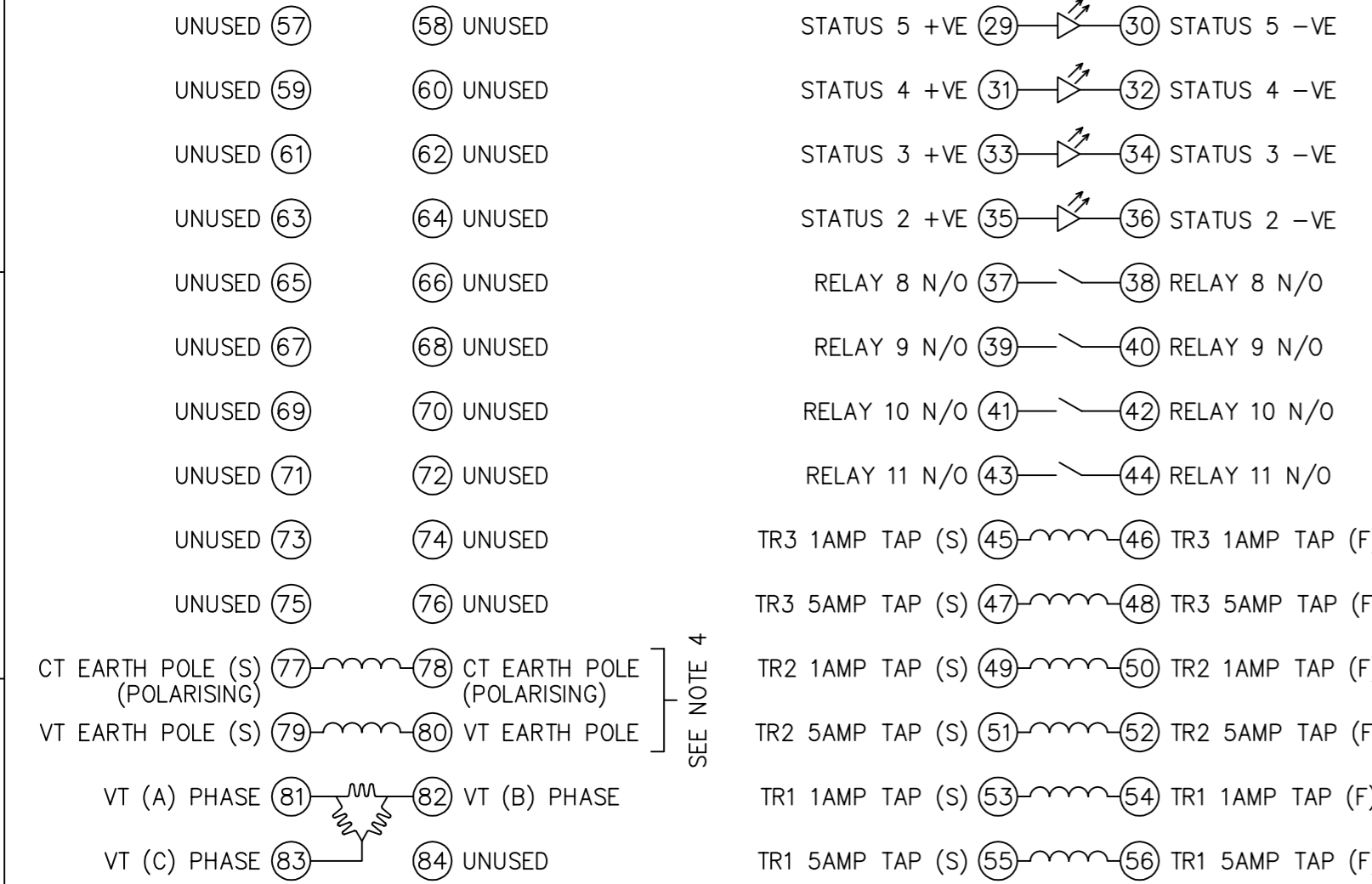

CONNECTIONS SHOWN FOR (OPTION B) 11 0/P+5 I/P
 SEE TABLE BELOW FOR (OPTION C) 7 0/P+9 I/P

C PHASE
 B PHASE OR EARTH
 A PHASE

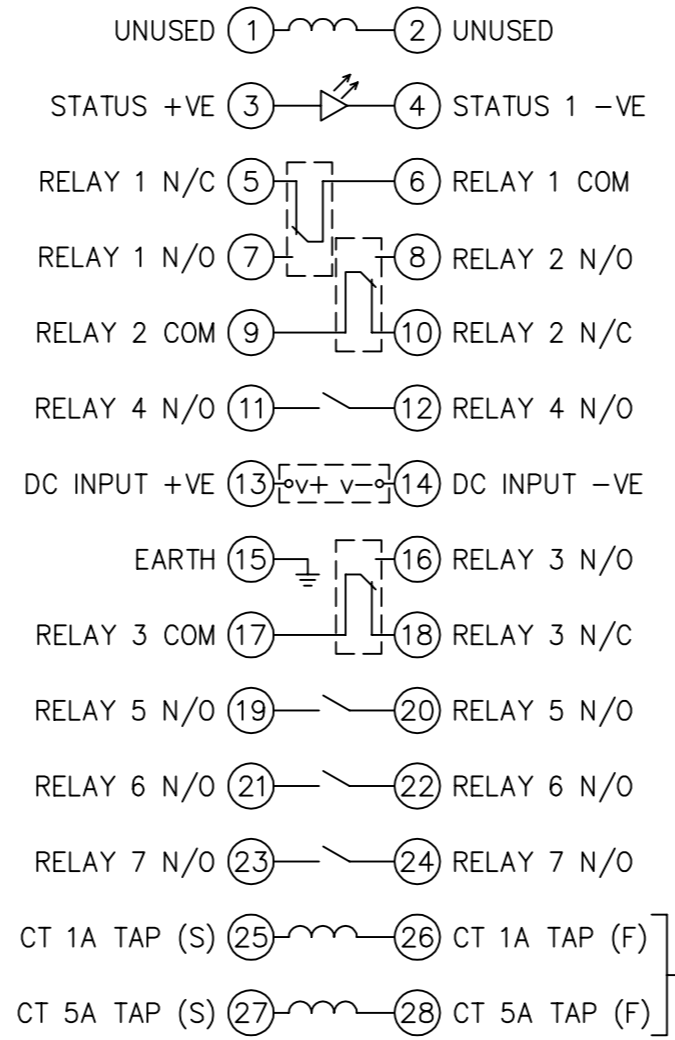

EARTH POLE
OR SEF/REF

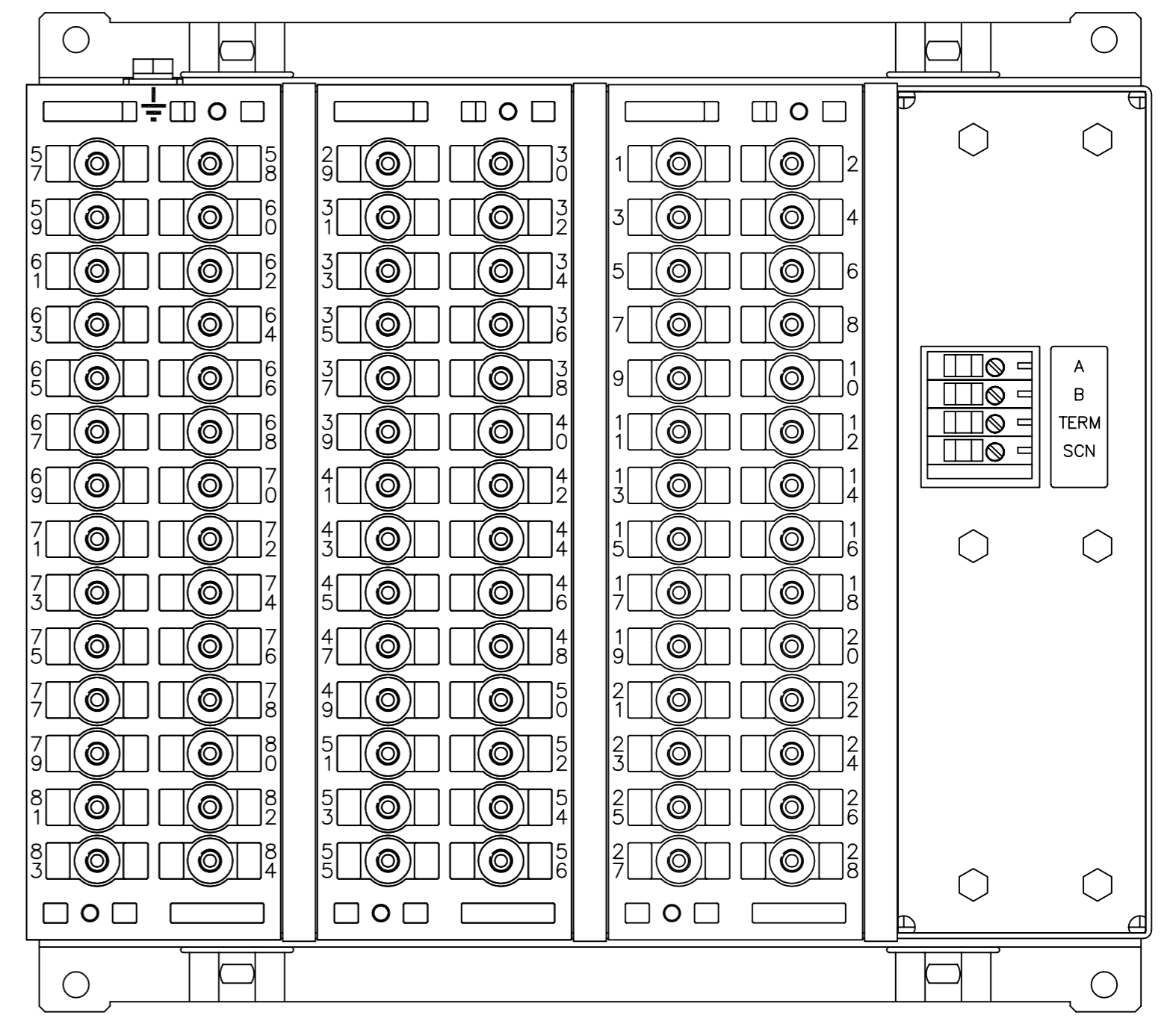

BOX VIEWED FROM REAR

OUTER TERMINAL BLOCK ASSY: -
VIEW BLOCK FROM THE INSIDE FACE

OUTER TERMINAL BLOCK ASSY: -
VIEW BLOCK FROM THE INSIDE FACE

OUTER TERMINAL BLOCK ASSY: -
VIEW BLOCK FROM THE INSIDE FACE

ASSEMBLY INSTRUCTIONS: -
TYPICAL ASSEMBLY DRAWING 2995G10029
AT INDICATED POSITIONS FIT AS FOLLOWS,
S - FIT STANDARD CONTACT
2995B10051
HC - FIT 'HEAVY CURRENT' KIT
2995G10030
WHERE -o- IS SHOWN FIT CT SHORTING KIT
2995G10031
POSITIONS SHOWN BLANK ARE UNUSED
ALL POSITIONS FIT SCREW 2106F12506

58	S	S	57
60	S	S	59
62	S	S	61
64	S	S	63
66	S	S	65
68	S	S	67
70	S	S	69
72	S	S	71
74	S	S	73
76	S	S	75
78	S	S	77
80	S	S	79
82	S	S	81
84	S	S	83

ASSEMBLY INSTRUCTIONS: -
TYPICAL ASSEMBLY DRAWING 2995G10029
AT INDICATED POSITIONS FIT AS FOLLOWS,
S - FIT STANDARD CONTACT
2995B10051
HC - FIT 'HEAVY CURRENT' KIT
2995G10030
WHERE -o- IS SHOWN FIT CT SHORTING KIT
2995G10031
POSITIONS SHOWN BLANK ARE UNUSED
ALL POSITIONS FIT SCREW 2106F12506

30	S	S	29
32	S	S	31
34	S	S	33
36	S	S	35
38	S	S	37
40	S	S	39
42	S	S	41
44	S	S	43
46	S	S	45
48	S	S	47
50	S	S	49
52	S	S	51
54	S	S	53
56	S	S	55

ASSEMBLY INSTRUCTIONS: -
TYPICAL ASSEMBLY DRAWING 2995G10029
AT INDICATED POSITIONS FIT AS FOLLOWS,
S - FIT STANDARD CONTACT
2995B10051
HC - FIT 'HEAVY CURRENT' KIT
2995G10030
WHERE -o- IS SHOWN FIT CT SHORTING KIT
2995G10031
POSITIONS SHOWN BLANK ARE UNUSED
ALL POSITIONS FIT SCREW 2106F12506

2	S	S	1
4	S	S	3
6	S	S	5
8	S	S	7
10	S	S	9
12	S	S	11
14	S	S	13
16	S	S	15
18	S	S	17
20	S	S	19
22	S	S	21
24	S	S	23
26	S	S	25
28	S	S	27

CHASSIS TERMINAL BLOCK ASSY: - (CHASS T/B 3)
VIEW FROM NUMBERED SIDE OF BLOCK

CHASSIS TERMINAL BLOCK ASSY: - (CHASS T/B 2)
VIEW FROM NUMBERED SIDE OF BLOCK

CHASSIS TERMINAL BLOCK ASSY: - (CHASS T/B 1)
VIEW FROM NUMBERED SIDE OF BLOCK

ASSEMBLY INSTRUCTIONS: -
TYPICAL ASSEMBLY DRAWING 2995G10032
AT INDICATED POSITIONS FIT AS FOLLOWS,
T - FIT TRIP ISOLATION CONTACT
2995B10053
S - FIT STANDARD CONTACT
2995B10054
POSITIONS SHOWN BLANK ARE UNUSED

2	T	T	1
4	T	T	3
6	T	T	5
8	T	T	7
10	T	T	9
12	T	T	11
14	T	T	13
16	T	T	15
18	T	T	17
20	T	T	19
22	T	T	21
24	T	T	23
26	T	T	25
28	T	T	27

ASSEMBLY INSTRUCTIONS: -
TYPICAL ASSEMBLY DRAWING 2995G10032
AT INDICATED POSITIONS FIT AS FOLLOWS,
T - FIT TRIP ISOLATION CONTACT
2995B10053
S - FIT STANDARD CONTACT
2995B10054
POSITIONS SHOWN BLANK ARE UNUSED

2	T	T	1
4	T	T	3
6	T	T	5
8	T	T	7
10	T	T	9
12	T	T	11
14	T	T	13
16	T	T	15
18	T	T	17
20	T	T	19
22	T	T	21
24	T	T	23
26	T	T	25
28	T	T	27

ASSEMBLY INSTRUCTIONS: -
TYPICAL ASSEMBLY DRAWING 2995G10032
AT INDICATED POSITIONS FIT AS FOLLOWS,
T - FIT TRIP ISOLATION CONTACT
2995B10053
S - FIT STANDARD CONTACT
2995B10054
POSITIONS SHOWN BLANK ARE UNUSED

2	T	T	1
4	T	T	3
6	T	T	5
8	T	T	7
10	T	T	9
12	T	T	11
14	T	T	13
16	T	T	15
18	T	T	17
20	T	T	19
22	T	T	21
24	T	T	23
26	T	T	25
28	T	T	27

- NOTES:
- TERMINALS RECOMMENDED ARE PRE INSULATED & MUST BE CRIMPED USING APPROVED TOOLING.
AMP PIDG OR PLASTI GRIP FUNNEL ENTRY (RING TONGUE) FOR M4 FIXING STUD.
SUPPLIER AMP CABLE SIZE
AMP 342103 0.25-1.6 SQ MM
AMP 342143 1.0-2.6 SQ MM.
OR ANY OTHER MANUFACTURERS EQUIVALENT TERMINAL.
 - FOR OUTLINE & DRILLING DRG SEE 2995X10008 (A4).
 - FOR TYPICAL CHASSIS ASSEMBLY SEE 2434H50006.
FOR TYPICAL CASE ASSEMBLY : RS485 COMMS. - SEE 2434H50014.
 - CT OR VT POLARISATION IS AVAILABLE
(FOR CLARITY DRAWING SHOWS BOTH CT AND VT TERMINATIONS)
 - CHASSIS TERMINAL BLOCK IDENTIFICATION REFERENCES (CHASS T/B 1, T/B 2 AND T/B 3) ARE FOR PRODUCTION IDENTIFICATION PURPOSES ONLY.

PROTECTION TYPE	SCHEMATIC DIAGRAM VERSION B	SCHEMATIC DIAGRAM VERSION C
3 PHASE(DIR)	2434W10121 (A3)	2434W10122 (A3)
2 PHASE(DIR)+SEF	2434W10123 (A3)	2434W10124 (A3)
2 PHASE(DIR)+EARTH(DIR)	2434W10125 (A3)	2434W10126 (A3)
2 PHASE(DIR)+EARTH		
3 PHASE(DIR)+EARTH(DIR)	2434W10127 (A3)	2434W10128 (A3)
3 PHASE(DIR)+EARTH		
3 PHASE(DIR)+SEF	2434W10129 (A3)	2434W10130 (A3)
2 PHASE(DIR)+EF(DIR)+SEF	2434W10131 (A3)	2434W10132 (A3)

NOT SUBJECT TO UPDATE
ONCE COPIED / PRINTED
OR DOWNLOADED

MATERIAL:

Dimensions in millimetres ; Surface texture in micrometres.
Machine where marked ✓
For explanation of dimensions, tolerances, notes etc. see B.S.308.
Limit on untoleranced unmachined dimensions ± _____
Limits on untoleranced machined dimensions to B.S.4500;
i.e. up to 6±0.1; over 30 to 120±0.3; over 315±0.8;
over 6 to 30±0.2; over 120 to 315±0.5;
General unmachined angular tolerance ± _____

Finish: _____
Treatment: _____

Title: TERMINAL IDENTITY & RELAY WIRING DIAGRAM
4 PLOE DIRECTIONAL ARGUS (E8 CASE) WITH RS485 COMMS.

Original Scale: 1:1

SIEMENS PROTECTION DEVICES LTD.

First used on: _____
Similar Articles: 2434H50003
Supersedes: _____
Drg. No. 2434W50010

Copyright © 2007 Siemens Protection Devices Ltd. Hebburn

1	12/02/07	CHANGE NOTED
ISSUE	DATE	