

IF IN DOUBT ASK  
DO NOT SCALE

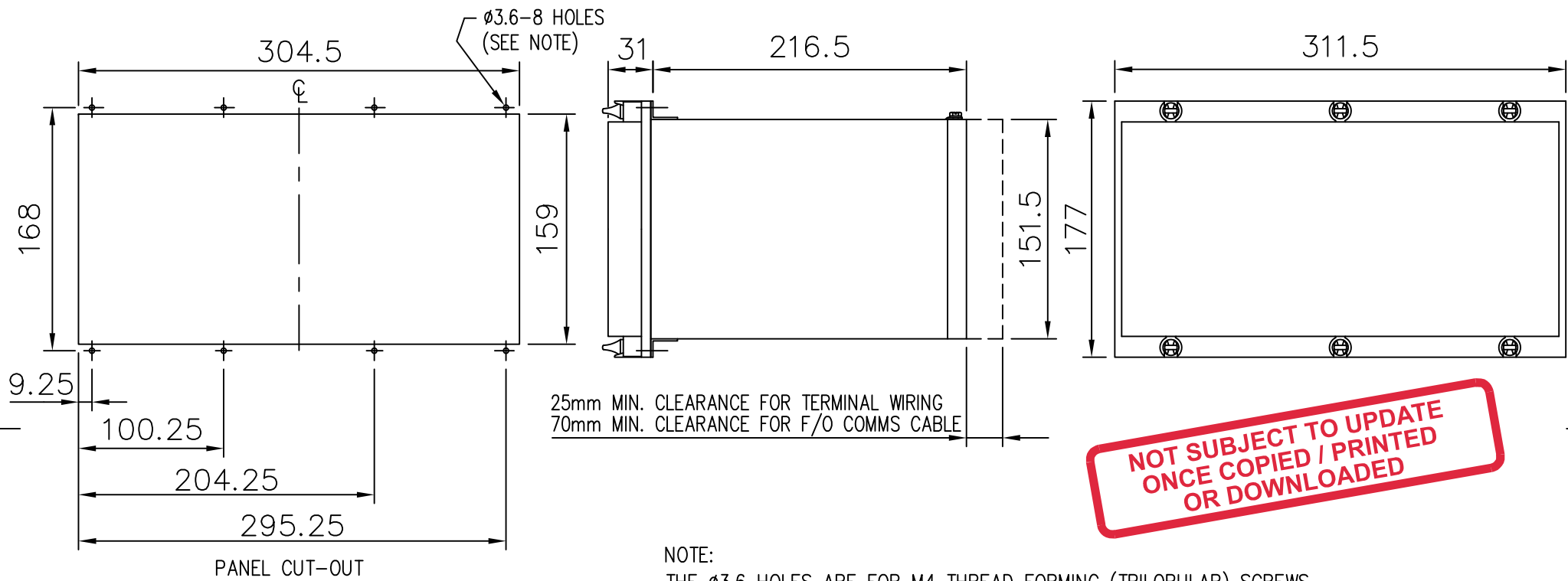

**NOT SUBJECT TO UPDATE  
ONCE COPIED / PRINTED  
OR DOWNLOADED**

NOTE:  
THE  $\phi 3.6$  HOLES ARE FOR M4 THREAD FORMING (TRILOBULAR) SCREWS. THESE ARE SUPPLIED AS STANDARD AND ARE SUITABLE FOR USE IN FERROUS/ALUMINIUM PANELS 1.6mm THICK AND ABOVE. FOR OTHER PANELS, HOLES TO BE M4 CLEARANCE (TYPICALLY  $\phi 4.5$ ) AND RELAYS MOUNTED USING M4 MACHINE SCREWS, NUTS AND LOCKWASHERS (SUPPLIED IN PANEL FIXING KIT).

4	RDW	04/06/07	MN995/2883 (AL)
3	RDW	27/09/06	MN995/2462 (ML/RDW)
2		30/07/01	MN995/2125
1	ISSUE	12/07/99	CHANGE NOTED $\triangle$

DRAWING OFFICE ONLY NOTE

ANY CHANGE TO THIS DRG MUST BE REFLECTED ON DRG 2995X10018 & CATALOGUE

MATERIAL:

Copyright © 1999 Siemens Protection Devices Ltd. Hebburn

Dimensions in millimetres : Surface texture in micrometres. Machine where marked $\checkmark$ For explanation of dimensions, tolerances, notes etc. see B.S.308. Limit on untoleranced unmachined dimensions $\pm$ _____ Limits on untoleranced machined dimensions to B.S.4500; i.e. up to $6\pm 0.1$ ; over 30 to $120\pm 0.3$ ; over 315 $\pm 0.8$ ; over 6 to $30\pm 0.2$ ; over 120 to $315\pm 0.5$ ; General unmachined angular tolerance $\pm$ _____	Finish:	Title: <b>OVERALL DIMENSIONS AND PANEL DRILLING FOR EPSILON E12 CASE</b>	First used on:
	Treatment:		Original Scale:
		<b>SIEMENS PROTECTION DEVICES LTD.</b>	Similar Articles: Supersedes: Drg.No. <b>2995X10012</b>
DRAWN: A.LAW	CHECKED:	APPROVED:	DATE: I.E. OPS. PCP. Purch. Spec. TQ. EAC CE. STD. A4h