



# SIMEAS R – Digital Fault Recorder with Power Quality (PQ) or Phasor Measurement Unit (PMU)

Energy Automation

Excerpt from Catalog SIP · 2008

Answers for energy.

**SIEMENS**



# C E R T I F I C A T E

## DQS GmbH

Deutsche Gesellschaft zur Zertifizierung von Managementsystemen

hereby certifies that the company

## Siemens AG

Power Transmission and Distribution Group (PTD)

Energy Automation (PTD EA)

Humboldtstraße 59  
90459 Nürnberg

with the organizational units/sites as listed in the annex

for the scope

Development, Production, Engineering, Sales and Service of Protection,  
Substation Automation, Telecontrol, Power Quality and Energy Management Systems

has implemented and maintains a

## Quality and Environmental Management System.

Audits, documented in a report, have verified that this  
management system fulfills the requirements of the following standards:

**DIN EN ISO 9001 : 2000**

December 2000 edition

**EN ISO 14001 : 2004**

November 2004 edition

This certificate is valid until 2009-05-31

Certificate Registration No. 000875 QM UM

Frankfurt am Main 2006-06-01

Ass. i.u. M. Drechsel

MANAGING DIRECTORS

Dipl.-Ing. G. Heintz



9-60433 Frankfurt am Main, August-Schanz-Straße 21



## SIMEAS R – Digital Fault Recorder with Power Quality (PQ) or Phasor Measurement Unit (PMU)



Fig. 13/60  
SIMEAS R

### Description

SIMEAS R as powerful disturbance (transient) recorder is available in two variations. On the one hand additionally with PQ-functionality (SIMEAS R V3.0) and on the other with PMU-functionality (SIMEAS R-PMU) according to IEEE C37.118. The following features are available: powerful disturbance (transient) recorder, power quality monitoring unit, power and frequency recording system, and event recorder. The disturbance recorder with a high sampling rate and excellent frequency response enables precise analysis of network disturbances. With the PMU vector quantities of voltages and currents with high accuracy in regard to amplitude, phase angle and time synchronization will be measured. It is possible to send in real time the phasors to a PDC and record them simultaneous with internal recorders. These records can be evaluated with OSCOP P. The power quality monitoring system for recording of voltage and current r.m.s. values, frequency, real and reactive power, power factor, current and voltage harmonics, voltage sags and swells, voltage flicker, etc. is a reliable tool to monitor and archive power quality related events. The power and frequency recording system is an important equipment in power plants to understand stability problems and analyze related topics like the response of generator excitation control systems. With an event recorder, various digital signals like the status of a breaker, isolator, and trip contacts of protection relays, etc. can be observed and recorded for further analysis. SIMEAS R as a field unit forms with OSCOP P software installed

on a DAKON PC (personal computer for data collection) a powerful disturbance recording system. One DAKON PC can communicate with several SIMEAS Rs using various communication channels. In the "Automatic mode", the DAKON PC is able to collect all data recorded by SIMEAS Rs.

With a flash memory for each SIMEAS R and practically unlimited storage capability on DAKON PCs and with a powerful database, the recording system enables excellent archiving possibilities.

The data obtained by SIMEAS R is written to a high-capacity internal bulk storage medium. Under normal conditions in substations, power plants and industrial systems, this type of storage takes months to fill up. When storage is full, it functions as a "ring buffer", overwriting the oldest values with the latest figures.

With a high sampling rate this unit records all relevant information for further analysis of short-circuits, breaker opening and closing behavior, reaction of CTs and VTs on network disturbances, etc. With a recording capability of 32 analog and 64 binary channels of each unit and with real-time synchronization capability, the system can observe and monitor a huge number of feeders and power equipment. SIMEAS R is a recorder meeting all electromagnetic compatibility requirements like all Siemens numerical relays. High level of hardware and software quality and precise self diagnosis of each unit is a guarantee for the investment of our customers.

### Function overview

- Disturbance recorder for applications in substations at MV/HV/EHV level and in power plants
- Power and frequency recorder for applications in power plants
- Power quality recorder for analysis and recording/archiving of power quality problems of all power applications
- Event recorder for binary signals for observation of the status of various primary components like breakers, isolators, etc.
- Transient recorder for DC signals
- Test recorder for commissioning and system test
- PMU according to IEEE C37.118 Measurement of vector quantities of voltages and currents with high accuracy in regard to amplitude, phase angle and time synchronization
- According to IEEE C37.118 internal recording of phasors via Transient and Continuous Phasor Recorder and parallel dispose the measured phasors to a Phasor Data Concentrator (PDC)

### Powerful recording system

- The field units SIMEAS R and the PC software OSCOP P form a powerful disturbance recording and power quality monitoring system. With a DAKON PC (Personal computer for data collection) in automatic mode, powerful data collection and archiving capability leads to very short analysis times
- Communication capability via Ethernet (LAN or WAN structure) in accordance with Ethernet 802.3 using TCP/IP protocol, communication via telephone network using ISDN or analog modem or direct communication using copper (RS232) or fiber-optic channels
- Various installation possibilities of the PC software OSCOP P in server, client and evaluation mode meet all requirements, like visualization, analysis for parameterization, commissioning, test, automatic data collection, data archiving
- Precise fault location capability using OSCOP P & diagnosis software
- Detailed power quality analysis information using SICARO PQ software

### Powerful hardware

- Modular hardware system with up to 32 analog and 64 binary inputs in a 19-inch rack
- Flash memory

### System overview

The DAKON is an industrial PC to which two or more SIMEAS R and numerical relays with the IEC 60870-5-103 protocol can be connected. In “automatic mode”, a DAKON can automatically fetch both data from SIMEAS R and the fault recordings from protection equipment, and write these to its own storage. Communication between the SIMEAS R, a DAKON and evaluation PCs is possible in various ways, for example via a wide area network (WAN) or local area network, with the TCP/IP protocol and electric or optical cables, as well as with converters and hubs. As an alternative, communication via analog or ISDN modems with a star coupler is also possible.

### Time synchronization

To enable a comparison of recordings from fault recorders and protection equipment at different locations, precise time synchronization of all SIMEAS R and DAKON devices is necessary. This is ensured by the use of additional components, such as GPS-receiver and sync-transceiver.

More details at the document “Application Note Time Synchronization” under [www.powerquality.de](http://www.powerquality.de)

### Analysis and evaluation software

All data recorded with SIMEAS R can be analyzed with the OSCOP P software package. OSCOP P is also used for parameterizing the SIMEAS R and archiving the fault recordings and mean values.

The DIAGNOSE software module is an optional additional package for OSCOP P, serving to work out the location of a fault in a line. Depending on data availability, the program can use fault recordings made at either end of a line to determine the fault location. The measured values recorded with the “mean value and power quality recorder” function can be analyzed with the SICARO PQ software package. For example, information can be obtained about the system voltage quality on a specific feeder.

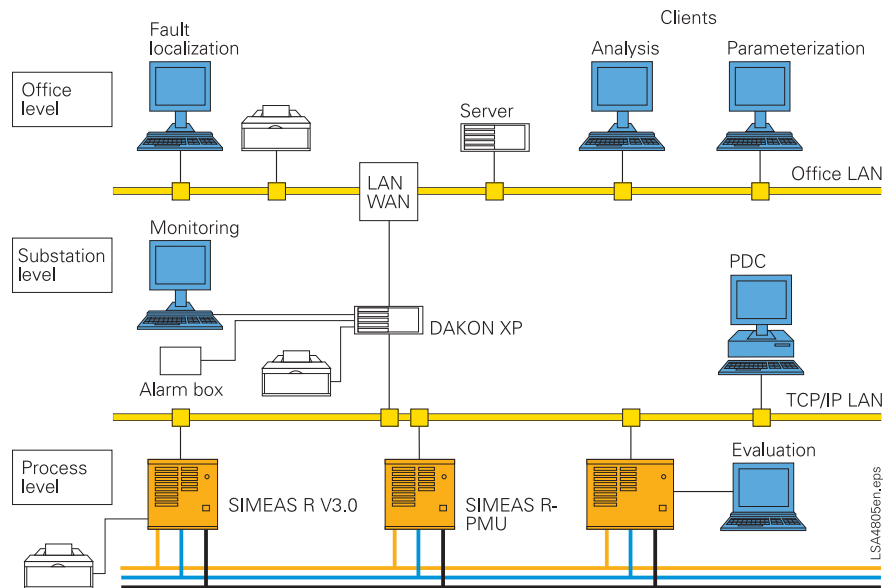

Fig. 13/61 System overview

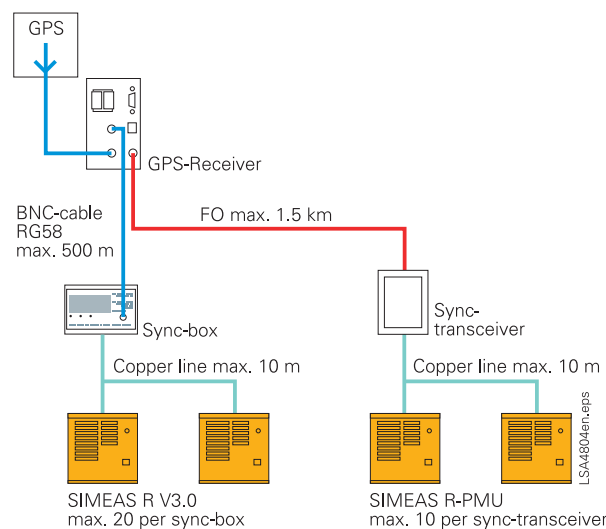

Fig. 13/62 Time synchronization

### Design and data acquisition units

The SIMEAS R recorder is available in two different housings. The smaller type (ZE8/16) can be equipped with one data acquisition unit (DAU). The larger type (ZE32/64) provides space for up to 4 DAUs. A selection of different DAUs enables flexible arrangement of inputs for current, voltage and DC voltage:

- VDAU (8 voltage channels)
- DAU (8 current channels)

- VCDAU (4 voltage and 4 current channels)
- DDAU (8 DC channels)

All data acquisition units described also feature 16 binary channels. If a larger number of binary signals is to be recorded, the recorder can optionally be equipped with a BDAU with 32 binary channels.



## Functions

### Dynamic fault recorder for analog and binary channels

The “fault recorder” function includes recording of analog and digital signals. These signals are continuously recorded and simultaneously compared with the parameterized trigger criteria. On triggering, all channels are recorded concurrently and with a pre-fault, variable fault progression and post-fault, depending on the parameter settings for recording.

### Recording alternating current and voltage

Three different data acquisition units are available for recording currents and voltages:

- VCDAU with 4 voltage and 4 current inputs,
- CDAU with 8 current inputs or
- VDAU with 8 voltage inputs.

SIMEAS R V3.0: The sampling rate is 256 x system frequency. For a system frequency of 50 Hz, the sampling rate is therefore 12.8 kHz (for 60 Hz, 15.36 kHz per channel).

SIMEAS R-PMU: The sampling rate is constant at 192 samples. For a system frequency of 50 Hz (frequency range 25 to 60 Hz) the sampling rate is constant at 9,600 Hz and for 60 Hz (frequency range 30 to 70 Hz) the sampling rate is constant at 11,520 Hz (see table page 13/52).

### Recording of the process variables

DC signals are measured via the DDAU data acquisition unit, which has 8 signal inputs. The DDAU can be ordered for an input range of -1 V to +1 V, -10 V to +10 V or -20 mA to +20 mA. These inputs can be assigned to one process signal each, e.g. display of temperature in K, speed of rotation in rpm, voltage in kV, current in kA.

### Recording of binary signals

The recording of binary channels is fully synchronized with recording of analog channels. The sampling rate is 2 kHz. A group of 16 binary inputs can record up to 250 state changes per second.

### Flexible triggering

With its numerous settable trigger conditions, SIMEAS R can be precisely adapted to the specific requirements of an application:

- **Triggering on the rms value of an analog channel (min. / max. triggering)**

For triggering, the recorder calculates a measured value corresponding to the rms value of a current or voltage ( $I$ ,  $V$ ) continuously at intervals of half a system cycle. The values sampled over half a system cycle are used to calculate this measured value.

Triggering occurs (i.e. recording is started) when the measured value either exceeds a positive maximum limit or falls below a positive minimum limit.

One practical example of this is triggering on a maximum value of the rms current and on a minimum value of an rms voltage.

- **Triggering on a change in the rms value of an analog channel ( $dM/dt$  triggering)**  
Each time the measured value described above ( $V$ ,  $I$ ) is calculated, the difference is formed between two measured values one system cycle apart. This difference is compared with the set rate-of-change ( $dM/dt$ ) limit, e.g. 10 kV / 20 ms. This permits triggering on a positive or negative change to the rms value of a voltage or current input.

- **Triggering on the rms value of the positive or negative sequence system (min. / max. triggering)**

The recorder can be parameterized to treat the analog inputs of a data acquisition unit as single, independent channels, or assign them to a three-phase system. In the latter case, positive and negative sequence components can be calculated both for current and voltage channels and used for triggering. Calculation of the measured quantities and of the triggering is performed as described under “Triggering on the rms value of an analog channel, min. / max. triggering”.



Fig. 13/63  
SIMEAS R, compact housing



Fig. 13/64  
SIMEAS R, front view.  
A DAU can be seen in the middle slot

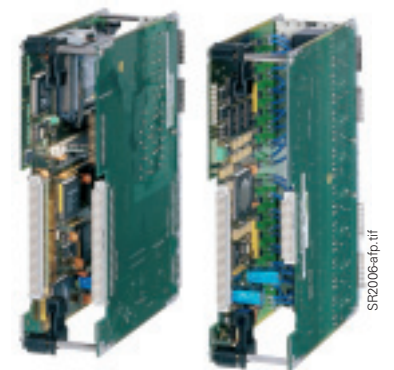

Fig. 13/65  
DAUs

## Functions (cont'd)

### Examples of logic gating:

- Voltage min. trigger threshold, recording reached, and current max.
  - Binary contact channel 1 high recording and current max. trigger reached
  - Binary contact 1, 3, 4 high and 6, 7, 9 low recording
- **Triggering on the limit of a DC channel (min. / max. triggering)**  
Triggering is performed when the sampled value of the DC signal exceeds the max. limit or falls below the min. limit.
  - **Triggering on the gradient of a DC channel (gradient triggering)**  
For the gradient trigger, the difference is calculated between two sampled values of a DC signal in a settable time interval. Triggering can be performed on a positive or negative gradient.
  - **Triggering on binary channels**  
Triggering to state (high or low), or on the positive or negative signal edge or on a binary input change is possible.
  - **Logic gating of trigger conditions**  
Analog and binary trigger conditions can be ANDed. The logic gating of triggers serves, for example, to distinguish a fault from an intentional line disconnection. The logic operation is applied to a settable time window from 0 to 1 s. If the triggering conditions are detected as “true” during this time window, recording starts. A total of 8 patterns with 8 start selectors each can be parameterized as trigger criteria.
  - **Triggering via the front panel (manual trigger)**  
This function is especially useful for commissioning work. It permits testing of the polarity of current and voltage channels and testing of phase angle offsets.
  - **Triggering via PC**  
This triggering is identical with the manual triggering but activated from the PC via the OSCOP P software.

- **Network trigger**

This triggering applies to devices communicating via an Ethernet network. Triggering is performed either from the PC for all connected SIMEAS R recorders, or sent from a SIMEAS R to further devices.

- **External trigger**

A recording start can be triggered externally via a separate binary input. Recording is limited to 10 s and is performed for as long as a voltage is applied to this input. The duration of the recording and the pre- and post-faults can be parameterized. Smart sequence control monitors the trigger conditions during recording. If retriggering is permitted and the maximum fault recording length is reached, a dynamic fault recording length is reached. For external triggering, time synchronization of all SIMEAS R devices in the system is required to ensure the fault records have the same time reference.

- **Cross trigger**

For the SIMEAS R-PMU the cross trigger has been activated for the Transient Analog Recorder (TAR). Recording by the Transient Analog Recorder will be started as soon as the Transient Phasor Recorder (TPR) has been triggered. In this case, the prefault time corresponds to the recording time that has been parameterized for the TAR. An extension (retriggering) of the TAR fault record can only be initiated by the TAR and not by another cross trigger of the TPR.

### SIMEAS R-PMU:

#### Phasor Measurement Unit (PMU)

The SIMEAS R-PMU is equipped with an integrated Phasor Measurement Unit (PMU) according to IEEE C37.118 – 2005. Among other things, this standard defines among others PMU quality criteria and the data formats.

At absolute instants of time, which are defined by the reporting rate, the PMU determines the phasors from the measured values and sends them to a Phasor Data Concentrator (PDC).

The phasor measurement requires a highly precise time synchronization ( $< 5 \mu\text{s}$ ) of the SIMEAS R-PMU device; especially if phasors of different locations are to be compared to each other.

#### Phasor Data Concentrator (PDC)

A PDC continuously receives data from one or several PMU devices. The Phasor Data Concentrator can switch the PMU ON or OFF and read out its configurations and channel descriptions. The data received by the PDC is visualized and may be stored in a database if necessary.

#### Complex phasors

A phasor  $\underline{v}(t) = \underline{V}e^{j\omega t}$  can be displayed as a pointer that rotates anticlockwise with the angular velocity  $\omega$  in the complex plane. The voltage  $v(t) = \text{Re}\{\underline{v}(t)\}$  is a result of the projection of the phasor  $\underline{v}(t)$  on the real axis.

#### Data recording

The phase angle of signal  $X_m$  is calculated in relation to a cosine function with the nominal frequency that has been synchronized with the UTC time reference (UTC = Coordinated Universal Time) (see Fig. 13/67).

**Functions**

The reporting rate defines the number of phasors transferred per second. If the defined sampling interval  $T_0$  is unequal to the integer multiple of the measuring signal cycle duration  $T_m$ , the phasors length remains constant, however, the phase angle is changed (see Fig. 13/68).

If the sampling interval  $T_0$  corresponds to the integer multiple of the measuring signal  $X_m$  cycle duration, a constant phasor is determined during every sampling instant.

**Reporting rate**

The parameterizable reporting rate of the SIMEAS R-PMU defines the number of telegrams that are created and transferred to the PDC per second. It can be set depending on the nominal frequency and equally applies to all data acquisition units (DAU) in the SIMEAS R-PMU. When selecting the reporting rate, the available bandwidth of the data connection to the PDC should always be considered (see Table 1).

**Transient Phasor Recorder (TPR)**

The TPR records the voltage and current curves, the derived values (e. g. active and reactive power) of the fundamental component, binary signals and process values in cycles when a fault occurs. For this purpose, the user defines trigger limits and recording times using the OSCOP P parameterization software. The input signals are analyzed according to the preset trigger conditions and recorded if the limit values are exceeded or not reached. The essential difference to the Transient Analog Recorder is the cycle-based determination of the measured and derived values, as well as a longer recording time. The fault record contains the pre-fault time, the trigger time and the recorded fault. The trigger cause is also stored.

The following trigger functions can be parameterized for the Transient Phasor Recorder:

- Level trigger Min/Max
- Gradient trigger
- Binary trigger
- Cross trigger
- Manual trigger
- External trigger
- Network trigger.

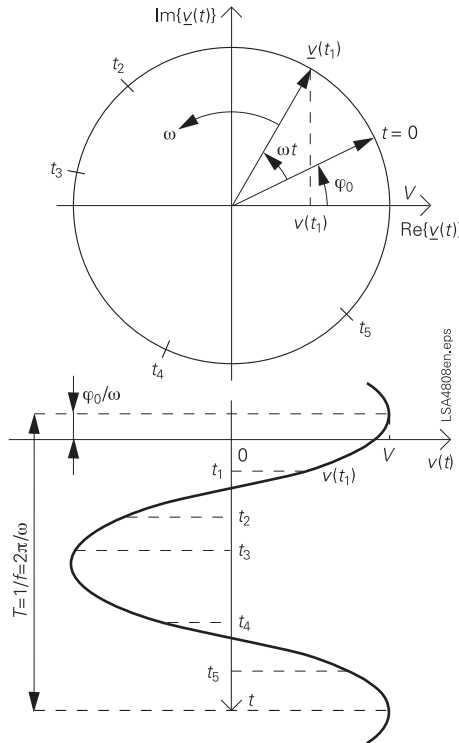

**Fig. 13/66** Geometrical illustration of a phasor

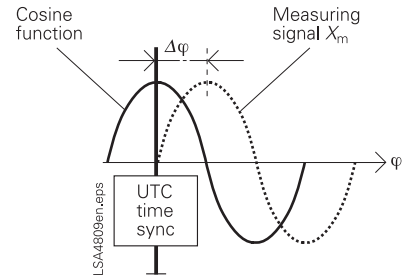

**Fig. 13/67** Determined the phase angle  $\varphi$  of the measuring signal  $X_m$  with regard to the cosine function

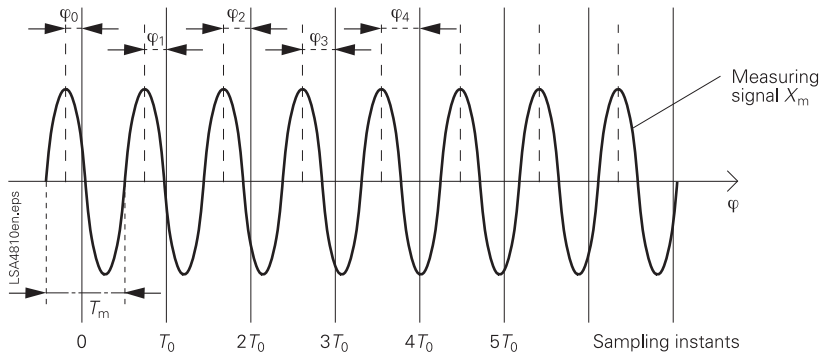

**Fig. 13/68** Sampling of the signal  $X_m$ ;  $T_m$  unequal  $T_0$

Name	Description								
Nominal frequency	$f_n = 50 \text{ Hz}$				$f_n = 60 \text{ Hz}$				
Reporting rate in telegrams/s	10	25	50 <sup>1)</sup>	10	12	15	20	30	60 <sup>1)</sup>
Recording values	VDAU, VCDAU, CDAU: phasors $V$ , $I$ or positive-sequence phasors, binary data DDAU: process values, binary data BDAU: binary data								

**Table 1** PMU-Technical Data

1) The reporting rates of 50 or 60 telegrams/second are not prescribed by the standard but are supported by the SIMEAS R-PMU.

## Functions (cont'd)

### Transient Analog Recorder (TAR)

The TAR records the curves for voltages, currents, process and binary signals in the form of sample values when a fault occurs. For this purpose, the user defines trigger limits and recording times using the OSCOP P parameterization software. The input signals are analyzed according to the preset trigger conditions and recorded if the limit values are exceeded or not reached. The fault record contains the prefault time, the trigger time and the recorded fault.

The trigger cause is also stored. The following trigger functions can be parameterized for the Transient Analog Recorder:

- Level trigger Min/Max
- Gradient trigger
- Binary trigger
- Logical trigger
- Cross trigger
- Manual trigger
- External trigger
- Network trigger.

### SIMEAS R V3.0:

#### Power and frequency recorder

The frequency and power recorder (SIMEAS R V3.0) calculates and stores the active and reactive power and the power factor plus the frequency ( $P$ ,  $Q$ ,  $\text{PF}(\cos \varphi)$  and  $f$ ). This function is used, for example, to record the load conditions before, during and after a fault in a power plant. Power swings in the power system and the frequency curve over a long time can be recorded.

One special application is recording of the properties of primary control in a power plant. For example, if a power plant unit is shut down at another location in a grid, the frequency of the power system will drop. This causes a considerable change in the power output of the power plant in which recording is taking place. Because all channels are recorded simultaneously, the user can establish a power balance, e.g. at the infeed points in substations.

### Recording principle SIMEAS R V3.0

The variables active power, reactive power, power factor and frequency ( $P$ ,  $Q$ ,  $\text{PF}(\cos \varphi)$  and  $f$ ) are continuously calculated at intervals of one system cycle and stored in a buffer. If the parameter “averaging time” is set to “1”, the calculation interval of the frequency and power recorder is one system cycle. The values in the fault recording therefore correspond to the values in the buffer. Other settings of the “averaging time” parameter can reduce the recorder’s calculation interval. For example, if the “averaging time” parameter is set to “4”, a mean value is formed over the 4 values of the variables ( $P$ ,  $Q$ ,  $\text{PF}(\cos \varphi)$ ,  $f$ ) last calculated and written to the buffer after 4 system cycles have elapsed. This means that the calculation interval of the fault recording is 4 system cycles. The “averaging time” parameter can be set in the range 1 to 250. The number of calculated values before the trigger point (pre-fault) can be selected in the range of 0 to 500.

The system frequency is measured via a voltage channel if the unit is equipped with an appropriate module (VDAU, VCDAU); if not, the frequency is measured via a current channel of a CDAU by automatic determination of the current signal with the highest amplitude and the lowest harmonic distortion.

### Power quality recorder and mean value recorder (SIMEAS R V3.0)

The mean value recorder and power quality recorder functions store the signals continuously. The averaging time for the groups listed below can be freely parameterized in the range of 10 s to one hour. The following electrical quantities are measured, stored and displayed in the evaluation program:

- Voltage and current
- Active and reactive power
- Frequency, positive and negative sequence system
- Weighted and unweighted THD
- Current and voltage harmonic
- Process variables
- Voltage dips
- Flicker

With this function it is possible to monitor a substation or part of a substation (e.g. feeder) continuously and to evaluate its power quality. The measurement is used for monitoring the rms current progression as well as the active and reactive power. This enables the energy requirement of a feeder to be averaged over a long period. Moreover, an analysis of the r.m.s. voltage, the current harmonic progression, the THD, the progression of voltage dips and flicker effects ( $P_{st}$  and  $P_{lt}$  value) provides information about the quality of the power supply on a feeder. Existing fault sources can thus be located and countermeasures taken.



## Functions

### Event recorder

With the independent “event recorder” function, SIMEAS R continuously records the status of the binary inputs and stores them in an event memory. This permits analysis of the state changes of the binary inputs over a long time, for example, several months. This is relevant, for example, for examining faults that occur on switching.

The described independent recording functions “analog and binary recorder, frequency and power recorder, mean value and power quality recorder and event recorder” can run in parallel depending on the parameter settings.

### Bulk storage

SIMEAS R features a bulk storage in flash technology to ensure the required high degree of reliability. During commissioning, it is possible to allocate separate areas to the various recorder functions, depending on the importance of the individual functions for the application.

The unit automatically reserves the memory range required for the operating system and firmware. Each memory range for recordings (a to d) is organized as a “circulating memory”. As soon as a memory range is 90 % full after several recordings, the procedure is as follows: the “latest fault record” is written to memory first, then the oldest recordings are deleted until the free capacity in this range reaches 80 % of the allotted memory size.

### Data compression

Even if you are using fast modem cards or a LAN/WAN connection, data compression is essential in a fault recorder to achieve:

- Efficient use of the device’s internal bulk storage as a distributed data archive
- Fast transmission of the fault recordings to a DAKON or an evaluation PC to enable a fault analysis to be performed immediately after the fault
- Acceptable transmission times when using slow transmission media, e.g. an analog modem
- Coping with LAN/WAN “bottlenecks”, which are particularly frequent in large-scale networks.

### Time synchronization (SIMEAS R V3.0)

Time synchronization is achieved via a special input of the processor module to which a synchronization box (7KE6000-8HA\*) is connected externally. Depending on implementation, the synchronization box can pick up the time signal from various receiver types, for example, via a GPS, DCF77 or IRIG-B. Synchronization with a GPS signal is the usual method. This requires special receivers that generally output a modulated telegram (DCF77, IRIG-B). This time telegram is passed on to the synchronization box. (In Germany and neighboring countries the DCF77 signal can be received directly. In this special case, the synchronization box can be connected to a DCF77 receiver with an integrated ferrite antenna.)

When configuring a fault recorder system, it is important to ensure that the right synchronization box is ordered for the receiver type. It decodes the receiver signal and sends a time telegram to the SIMEAS R with an internal protocol.

Independently of this synchronization, it is also possible to synchronize with a minute pulse via a binary input. This feature can be used to reset the second hand of the SIMEAS R’s internal clock to zero on each pulse.

If external synchronization fails, all the data acquisition units (DAUs) of a recorder are synchronized by the internal clock. The time is adjusted automatically on recovery of the synchronization telegram. If two or more recorders are used at a single mounting location, the signal from the synchronization box is wired to the control input of the various recorders in parallel.

If the synchronization signal has to be distributed via optical cables due to a substantial distance between the various SIMEAS R recorders, the following additional components are required:

- Sync FO distributor: converts the 24 V signal of the synchronization box to 8 FO outputs (7KE6000-8AH/8AJ).
- Sync transceiver: converts the FO signal to 24 V (7KE6000-8AK/8AL).

### Time synchronization (SIMEAS R-PMU)

The SIMEAS R-PMU 7KE6100 Phasor Measurement Unit (PMU) requires a norm compliant precise time signal for phasor measurement. GPS receiver Hopf 6875 7XV5664-0AA00 (SIPROTEC version) provides the required precision, when you use the optic fibre output FL2 of the timer module. The electrical outputs must not be used. As an alternative, SIMEAS R can be synchronized via minute impulse. This mode does not provide the accuracy of DCF77 synchronization. In particular PMU cannot be used in this mode. For very complex networks, a passive star coupler has to be used. This device allows you to use 5 fibre optic cables instead of 1.

Note: SIMEAS R-PMU uses the original DCF77 signal for synchronization. A synchronization box 7KE6000-8HAxx is not required and cannot be used for SIMEAS R-PMU. If you use DCF77 synchronization the synchronization input (binary input 1) of the SIMEAS R CPU board has to be designed for 24 V DC (7KE6100-xx xxx 1xxx, 7KE6100-xx xxx 5xxx, 7KE6100-xx xxx 6xxx or 7KE6100-xx xxx 7xxx)

## Functions (cont'd)

### Communication interfaces and components

SIMEAS R features the following communication interfaces:

- COM-S interface**  
 This RS232 interface on the front panel is for direct communication with an evaluation PC. This interface can be used to parameterize and test the recorder during commissioning. It has fixed communication parameters.
- COM1 interface**  
 This serial interface (RS232) is located on the rear of the recorder. This interface enables the recorder to communicate via an external analog or ISDN modem. The recorder can then be connected to a telephone network, but a direct modem-to-modem connection is also possible. The communication parameters of this interface can be set.
- Ethernet interface**  
 This integrated interface is used to connect the recorder to a LAN (local area network) IEEE 802.3 (10 Mbps Ethernet) with the TCP/IP protocol. (Please note that recorders delivered up to about February 2003 have a PCMCIA slot for an Ethernet card at the rear).
- Ethernet structure**  
 The network used to connect to an evaluation PC or a DAKON has star topology. One or more connection nodes (hubs) can be used. To improve the reliability of communication channels, optical cables can be used for the network. The following components can be used to set up an optical network:
  - Transceiver (7KE6000-8AF/8AG)**  
 Converter from 10BASE-T ports with copper cable to 10BASE-FL with optical cable. The unit has an FO and a 10BASE-T network port. Housing: DIN rail mounting.
  - Multipoint repeater, or hub (7KE6000-8AD/8AE)**  
 This hub enables connection to two or more Ethernet cable segments. The unit has one FO and six 10BASE-T network ports. Housing: DIN rail mounting.

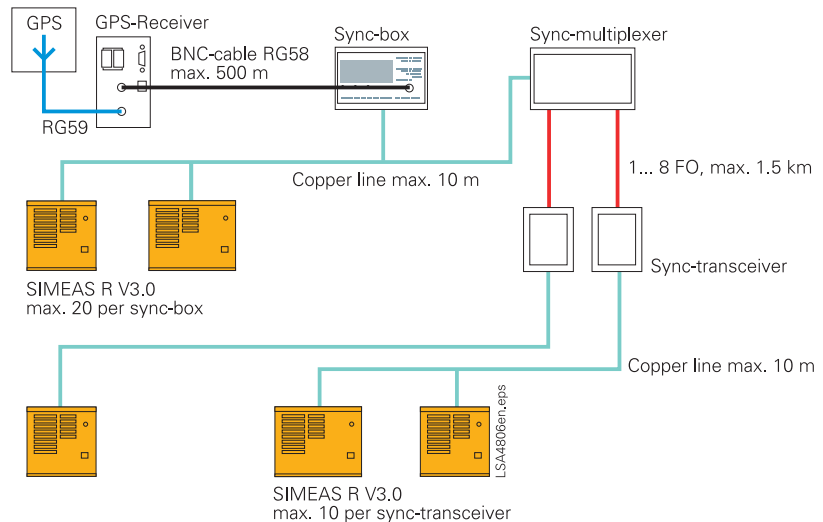

Fig. 13/69 Time synchronization SIMEAS R V3.0

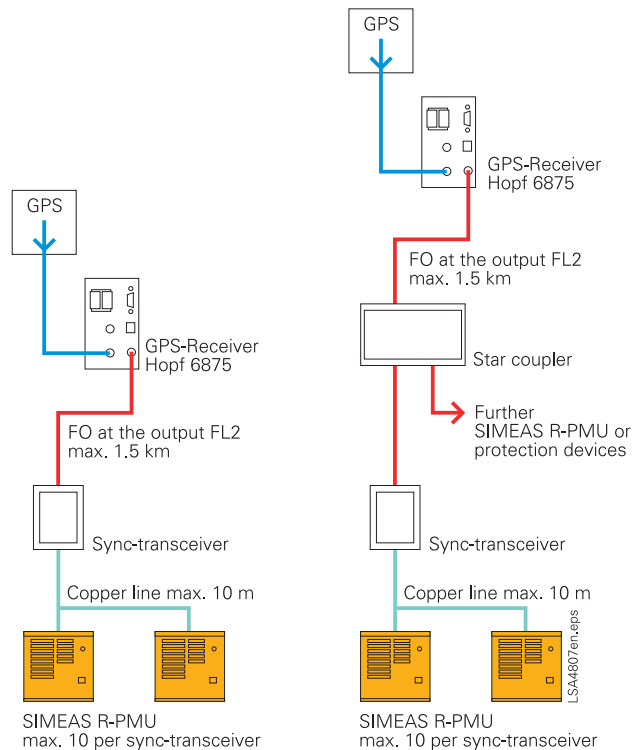

Fig. 13/70 Time synchronization SIMEAS R-PMU

## Hardware

### Housing

Two types of housing are available for SIMEAS R:

- 1/2 19-inch rack with 3 slots and
- 19-inch rack with 6 slots

The first slot is filled by the CPU module, the last slot of each rack by the PSU. The remaining slots can be filled with various data acquisition units (DAUs). The modules are slotted into the rack vertically and the terminals are located at the rear of the rack.

### Central processor

The central processor coordinates the data acquisition units, communication via the interfaces, and manages the database for the various fault records and mean values. It also monitors the entire hardware.

### Power supply

The power supply is drawn from two different units (PSUs), depending on the supply voltage:

- 24 V - 60 V DC
- 110 V - 250 V DC and 115 - 230 V AC

In the event of a sudden power failure, the recorder continues to function, drawing its power from a storage capacitor (for details such as duration, see “Technical Data”). This allows time for a controlled reset if the power supply fails during operation. The PSU can optionally be equipped with a battery. The battery ensures operation for up to 10 minutes. The battery is loaded automatically and its charge state is monitored by an independent circuit. With a weekly automatic load test, the memory effect of the battery is reduced. Use of the battery is especially recommended if the recorder is powered from an AC source without PSU back-up.

### Data Acquisition Units (DAUs)

The following data acquisition units are available for the unit:

- VCAU: 4 current / 4 voltage channels and 16 binary channels
- VDAU: 8 voltage channels and 16 binary channels
- CDAU: 8 current channels and 16 binary channels
- DDAU: 8 channels for process variables and 16 binary channels
- BDAU: 32 binary channels



**Fig. 13/71**  
Layout of a SIMEAS R

- 1 CPU module
- 2 Data acquisition unit DAU
- 3 Power supply unit
- 4 Bus board



**Fig. 13/72**  
Rear view

### Analog-to-digital converters

Each analog channel has a 16-bit analog-to-digital converter (ADC) with an integrated dynamic anti-aliasing filter. This obviates use of an external anti-aliasing filter. The anti-aliasing filter automatically adapts to the network environment because the recorder sampling rate and therefore the sampling rate of the ADC are set with the parameter for the rated system frequency.

**Hardware (cont'd)****Dynamics of the current channels**

The CDAU comprises eight (and the VCDAU four) current channels. Each current channel has two independent ADCs. The first ADC is connected to an inductive current transformer (CT) that is optimized for the current range of 0 to 7 A (r.m.s. value) and dimensioned for very high precision. If a higher current is measured, the recorder automatically switches over to the input of the second CT. This CT is connected to a hall generator that measures the same current as the inductive transformer but is optimized for the 0 to 600 A range (high dynamics). Because the hall generator also transmits DC, its frequency range does not have a lower limit. Use of two different transformer principles ensures that the recorder measures very accurately in the nominal range of the line current and, in the event of a fault, records current curves with high amplitude and sustained DC component without any loss of information.

**Current terminals**

If a CDAU or VCDAU is removed from the rack, the current terminals are automatically shorted out to avoid damaging the connected CT.

**Channels for process signals****SIMEAS R V3.0:**

The sampling rate of a DDAU is a fixed 10 kHz, if other DAU types are used in the recorder. However, if a recorder contains only DDAUs, sampling rates of 10 Hz / 100 Hz / 1 kHz / 10 kHz can be parameterized.

A low sampling rate setting is recommended for monitoring slowly varying process variables (to keep the recorded data volume manageable). These channels can be connected to  $\pm 10$  V,  $\pm 1$  V or  $\pm 20$  mA, depending on the type.

**SIMEAS R-PMU:**

The sampling rate of a DDAU in the SIMEAS R-PMU is fixed to 192 samples per cycle. For a nominal frequency of 50 Hz (frequency range 0 to 500 Hz) the sampling rate is 9,600 Hz and for a nominal frequency of 60 Hz (frequency range 0 to 500 Hz) the sampling rate is 11,520 Hz.

**Configuration notes**

The PCMCIA memory and communication cards used for the modem or Ethernet in PCCARD technology are constantly undergoing further development. Because they are used in substations, where CE markings are prescribed, only cards approved by Siemens may be used in the system. In particular, the system noise immunity stipulated by the applicable IEC regulations and the high ambient temperature range necessitate special cards. The planning department should be consulted about selecting the correct PCs and correctly setting up the overall system.

**Modes**

The SIMEAS R has three operating modes:

**Normal mode**

In normal mode all functions are active.

**Blocked mode**

In blocked mode, the recording functions “dynamic recorder for analog and binary channels” and “power and frequency recorder” are inactive, i.e. no fault records are recorded. If this mode is selected, only the functions “mean value and power quality recorder” and “event recorder” are active. The mode is used, for example, to test equipment connection during commissioning.

**Test mode**

In test mode, all functions are active but recorded events are entered with “test” as their cause. The “event recorded” alarm relay does not pick up. “Test mode” is used to check the functionality of the SIMEAS R. The different modes can be selected on the keyboard. Remote control via OSCOP P is possible at any time.

**LEDs on the front panel of the recorder**

The front panel of the recorder contains 8 red and 8 green parameterizable LEDs assigned as follows:

**SIMEAS R-PMU**

- Recorder in operation
- Operating voltage OK
- Battery capacity OK
- Event being recorded
- Recorder synchronized
- Circulating memory active
- PMU active
- DAU error
- Printer fault
- Data memory fault
- Synchronization fault
- PC not accessible
- Temperature fault
- Spare (freely parameterizable)

and 5 LEDs permanently assigned to the control buttons listed below.



## Hardware

### Control buttons

The recorder has the following control buttons that are located on the front panel:

- Acknowledge group alarm
- Normal mode
- Blocked mode
- Test mode
- Manual trigger

### Control inputs

There are four contact inputs at the rear of the recorder:

- Acknowledge group alarm
- System reset
- External start
- Time synchronization

### Alarm outputs

The recorder has four alarm outputs. The first is permanently connected to the processor watchdog. The other three can be freely parameterized and are pre-assigned as follows:

- Watchdog (permanent, not parameterizable)
- E.g. ready to run (parameterizable)
- E.g. event being recorded (parameterizable)
- E.g. group alarm (parameterizable)

### Group alarm

Here is an example of how the group alarm can be parameterized. Up to 5 signals can be parameterized for the group alarm:

- DAU fault
- Printer fault
- Synchronization fault
- CPU fault
- Data fault



Fig. 13/73 LEDs and control buttons

### SIMEAS R V3.0

#### 8 green LEDs

- Recorder in operation
- Operating voltage OK
- Battery capacity OK
- Event recorded
- Data transmission to the PC
- Circulating memory active
- Two further LEDs freely programmable

#### 8 red LEDs

- Fault DAU(s)
- Fault printer
- Fault time synchronization
- Fault fine synchronization
- Fault data memory
- PC not accessible
- Temperature  $\leq 5^{\circ}\text{C}$
- Temperature  $\geq 55^{\circ}\text{C}$ ,

and 5 LEDs permanently assigned to the control buttons listed below

#### Control buttons

The recorder has the following control buttons that are located on the front panel:

- Acknowledge group alarm
- Normal mode
- Blocked mode
- Test mode
- Manual trigger

#### Control inputs

There are four contact inputs at the rear of the recorder:

- Acknowledge group alarm
- System reset
- External start
- Time synchronization

#### Alarm outputs

The recorder has four alarm outputs. The first is permanently connected to the processor watchdog. The other three can be freely programmed and are pre-assigned as follows:

- Watchdog
- Ready to run
- Event being recorded
- Group alarm

#### Group alarm

- Fault DAU(s)
- Fault printer
- Fault synchronization
- Fault data memory

LSP2624.tif

## Technical data

## Mechanical design

## 1/2 19" version

Dimensions (W x H x D)	223 x 266 x 300 mm
Number of slots	3
<b>Slot 1 - CPU</b>	
<b>Slot 2 DAU</b>	See "Analog and binary in- and outputs"
<b>Slot 3 Power supply unit</b>	

## 19" version

Dimensions (W x H x D)	445 x 266 x 300 mm
Number of slots	6
Slot 1 - CPU	Approx 1.5 mA/input
Slot 2 - 5 DAU	See "Analog and binary in- and outputs"
Slot 6 Power supply	

## Auxiliary voltage

## Low-voltage version

DC voltage	
Rated auxiliary DC voltage $V_{aux}$	24/28/60 V DC
Permissible voltage ranges	19.2 to 72 V DC

## High-voltage version

DC voltage	
Rated auxiliary DC voltage $V_{aux}$	110/125/220/250 V DC
Permissible voltage ranges	88 to 300 V DC
AC voltage 50/60 Hz	
Rated auxiliary DC voltage $V_{aux}$	115/230 V AC
Permissible voltage ranges	92 to 276 V AC

## Voltage stability without back-up battery

Bridging time	Measured times	
	Central unit	
	ZE8/16	ZE32/64

for $V_{aux} = 24$ V DC	$\geq 400$ ms	$\geq 150$ ms
for $V_{aux} = 60$ V DC	$\geq 450$ ms	$\geq 170$ ms
for $V_{aux} = 110$ V DC	$\geq 500$ ms	$\geq 180$ ms
for $V_{aux} = 250$ V DC	$\geq 700$ ms	$\geq 200$ ms
for $V_{aux} = 115$ V AC	$\geq 500$ ms	$\geq 200$ ms
for $V_{aux} = 230$ V AC	$\geq 800$ ms	$\geq 348$ ms

**Optionally with back-up battery** Power failure bridging time up to 10 min with all functions operating

## Power consumption

1/2 19" version		
8 analog / 16 binary channels	24 to 60 V DC	20 W
	110 to 250 V DC	18 W
	115 to 230 V AC	30 VA
19" version		
32 analog / 64 binary channels	24 to 60 V DC	45 W
	110 to 250 V DC	40 W
	115 to 230 V AC	70 VA

## Analog and binary inputs and outputs

Slot 2 (1/2 19" version)	To be equipped according to table "Equipping version"
Slot 2 to 5 (19" version)	To be equipped according to table "Equipping version"
Equipping versions	
VCDAU	8 analog (4 current / 4 voltage) and 16 binary channels
CDAU	8 analog (8 current) and 16 binary channels
VDAU	8 analog (8 voltage) and 16 binary channels
BDAU	32 binary channels
DDAU	8 analog (8 current $\pm 20$ mA or 8 voltage $\pm 1$ V or $\pm 10$ V) and 16 binary channels

## SIMEAS R-PMU

DAU type	Rated frequency	Frequency range	Sampling frequency	Sampling rate
VCDAU; VDAU; CDAU	50 Hz	25 to 60 Hz	9,500 Hz	192
DDAU	50 Hz	0 to 500 Hz		
VCDAU; VDAU; CDAU	60 Hz	30 to 70 Hz	11,520 Hz	
DDAU	60 Hz	0 to 500 Hz		

## SIMEAS R V3.0

VCDAU, CDAU and VDAU	Sampling frequency	Rated frequency	Frequency range
	4.3 kHz	16.7 Hz	12 to 20 Hz
	12.8 kHz	50 Hz	40 to 60 Hz
	15.36 kHz	60 Hz	50 to 70 Hz
	64 times oversampling		

If a recorder contains only DDAUs, it is possible to parameterize the sampling rates 10 Hz / 100 Hz / 1 kHz / 10 kHz. If the recorder also contains other DAUs, the sampling rate of the DC signals is always 10 kHz.

## Voltage input (VDAU or VCDAU)

<b>Measuring range 1</b>	1.5 to 200 $V_{rms}$
Impedance	$> 100$ k $\Omega$
Resolution	15 mV
Overvoltage	Max. 300 $V_{rms}$ for 5 s
Accuracy (at 23 °C 1 °C and rated frequency)	Class 0.3 $\pm 0.25$ % of measured value $\pm 30$ mV
Frequency response	3 to 5500 Hz (5 %)
Number of analog-digital converters per channel	1
<b>Measuring range 2</b>	3 to 400 $V_{rms}$
Impedance	$> 200$ k $\Omega$
Resolution	30 mV
Overvoltage	Max. 600 $V_{rms}$ for 5 s
Accuracy (at 23 °C 1 °C and rated frequency)	Class 0.3 $\pm 0.25$ % of measured value $\pm 30$ mV
Frequency response	3 to 5500 Hz (5 %)
Number of analog-digital converters per channel	
Voltage channel	1
Current channel	2

## Technical data

## Analog and binary inputs and outputs (cont'd)

## Current input (CDAU or VCDAU)

Dynamic AD and converter switching	
Measuring range	5 mA to 400 A <sub>rms</sub>
Accuracy range	5 mA to 7 A <sub>rms</sub>
Resolution	0.5 mA
(at 23 °C ± 1 °C and rated frequency)	Class 0.5
Frequency response	± 0.5 % of measured ± 0.5 mA
	3 to 5500 Hz (5 %)
Range	> 7 A <sub>rms</sub> to 200 A <sub>rms</sub>
Resolution	30 mA
(at 23 °C ± 1 °C and rated frequency)	Class 1.5
Frequency response	± 1.5 % of measured value ± 30 mA
	0 to 5500 Hz (5 %)
Range	> 200 A <sub>rms</sub> to 400 A <sub>rms</sub>
Resolution	30 mA
(at 23 °C ± 1 °C and rated frequency)	Class 3.5
Frequency response	± 3.5 % of measured value
	0 to 5500 Hz (5 %)
Continuous Overload	20 A
	100 A, 30 s
	500 A, 1s
	1200 A, half-wave
Recording Burden	200 A, plus 100 % displacement
	< 0.1 VA

## DC inputs (DDAU)

Input range (depending on the Order No.)	± 20 mA (50 Ω) ± 1 V / ± 10 V (> 40 kΩ / > 400 kΩ)
Accuracy (at 23 °C ± 1 °C)	Class 0.5
Range 1 V	± 0.5 % measured value ± 1 mV
Range 10 V	± 0.5 % measured value ± 10 mV
Range 20 mA	± 0.5 % measured value ± 20 μA
Sampling frequency	10 Hz, 100 Hz, 1 kHz, 10 kHz per module (parameterizable) (if used together with a VCDAU, CDAU, or VDAU, the DC channels are recorded in parallel. Only a sampling rate of 10 kHz per channel is permitted.)
	Processing of higher DC voltages via isolation amplifier (e.g. SIMEAS T)

## Analog and binary inputs and outputs (cont'd)

## Binary inputs (BDAU, VCDAU, DDAU, CDAU und VDAU)

Sampling frequency	2 kHz		
Principle of storage	Only status changes are stored with real time and a resolution of 1 ms		
Storage capacity	250 status changes per 16 inputs, within 1 s, total storage capacity depends on the parameter setting (typically approx. 100,000 status changes)		
Voltage ranges of control inputs according to components installed	Input voltage	L-level	H-level
	V	V	V
	24	≤ 7	≥ 18
	48 to 60	≤ 14	≥ 36
	110 to 125	≤ 28	≥ 75
	220 to 250	≤ 56	≥ 165
	Input current 1 mA		
	Input voltage	Overload	
	V	V	
	24	28.8	
	48 to 60	72	
	110 to 125	150	
	220 to 250	300	

## Binary inputs and outputs

Control inputs	4 inputs		
Input 1	Input for time synchronization for connection to the synchro-box or a station clock with minute pulse 24 to 60 V, filter time > 2 μs > 110 V, filter time < 5 μs		
Input 2	External start, filter time 50 ms		
Input 3	External reset filter time 50 ms		
Input 4	External group alarm Filter time 50 ms		
Voltage ranges of control inputs according to components installed	Input voltage	L-level	H-level
	V	V	V
	24	≤ 7	≥ 18
	48 to 60	≤ 14	≥ 36
	110 to 125	≤ 28	≥ 75
	220 to 250	≤ 56	≥ 165
	Input current 1 mA		
	Input voltage	Input 1 Overload	Input 2 to 4 Overload
	V	V	V
	24	28.8	28.8
	48 to 60	72	72
	110 to 125	150	150
	220 to 250	300	300

## Technical data

Signal outputs	
Switching capacity	4 signal outputs with isolated main contact, signal output 1 hard-wired to watchdog, 3 signals outputs freely allocatable. MAKE 30 W/VA BREAK 20 VA 30 W resistive 25 W for L/R ≤ 50 ms
Switching voltage	250 V
Permissible current	1 A continuous
Allocation of the signal outputs and status of LEDs	SIMEAS R ready for operation Operating voltage OK Normal mode Test mode Locked mode Transmission SIMEAS R - PC active Recording event DAU fault Printer fault Time synchronization error Computer not available Data memory fault Data memory full Cyclic storage active Battery capacity OK Temperature monitoring < -5 °C Temperature monitoring > +55 °C Fine synchronization error Group alarm Relay 1 - not allocatable; watchdog Relay 2 - not allocatable Relay 3 - not allocatable Relay 4 - not allocatable

## Communication interfaces

## Slot 1 - CPU

LPT 1	Printer interface, Centronics, for connection of a laser printer (Emulation Postscript level 2)
COM 2/COM S	RS232 serial interface, on front side for connection of a PC, 19.2 kBd
COM 1	RS232 serial interface, on rear for connection of e.g. an additional modem, 300 Bd to 57.6 Bd or an external ISDN terminal adapter
Ethernet	Compatible acc. to IEEE 802.3 Software TCP/IP Twisted pair (10BaseT), RJ45 connector

## Slot 0 data transmission

Modem	Transmission rate up to 56 kbps Dialing method audio and pulse CCIT V.21, V.22, V.22 to V.23, V.32, V.32 to V.34, V.90 Certified in all European countries
-------	---

Further technical information on  
<http://www.powerquality.de>

## Climatic stress

## Temperatures

Transport and storage	-25 °C to +70 °C
Operation for cubicle/panel flush-mounting	-5 °C to +55 °C (condensation not permissible)
for panel surface-mounting	0 °C to +40 °C

## Humidity

95 % without condensation

## SIMEAS R-PMU

## Mass storage: 1 GB Flash Card

## Available recorder

PMU according to IEEE C37.118 and parallel

Triggered recorder	<b>Transient Analog Rec (TAR):</b> $\underline{U}_{L,N}; \underline{I}_{L,N}; \underline{U}_{1,2,0}; \underline{I}_{1,2,0}; B; D$ <b>Transient Phasor Rec.(TPR):</b> $\underline{U}_{L,N}; \underline{I}_{L,N}; \underline{U}_{1,2,0}; \underline{I}_{1,2,0}; B;$ $D; f; P; Q$
Continuous recorder	<b>Cont. RMS Rec (CRR):</b> $\underline{U}_{L,N}^{(1)}; \underline{I}_{L,N}^{(1)}; \underline{U}_{1,2,0}^{(1)}; \underline{I}_{1,2,0}^{(1)}$ <b>Cont. Q (Power) Rec. (CQR):</b> $Q^{(1)}, P^{(1)}$ <b>Cont. Frequency Rec. (CFR):</b> $f^{(1)}$ <b>Cont. DC Rec. (CDR):</b> $D^{(1)} (\pm 20 \text{ mA}; \pm 1 \text{ V}; \pm 10 \text{ V})$ <b>Event Rec. (ER): B</b> <b>Cont. Phasor Rec. (CPR):</b> $\underline{U}_{L,N}; \underline{I}_{L,N}; f;$

## SIMEAS R V3.0

## Mass storage: 512 MB Flash Card

## Available recorder

Triggered recorder	<b>U, I:</b> $\underline{U}_{L,N}; \underline{I}_{L,N}; B; D$ <b>f, P:</b> $P; Q; \cos\varphi; f$
Continuous recorder	<b>U, I:</b> $\underline{U}_{L,N}^{(1)}; \underline{I}_{L,N}^{(1)}$ <b>P, Q:</b> $Q^{(1)}, P^{(1)}$ <b>f, sym:</b> $f^{(1)}, U^{(1)}_{1,2}; I^{(1)}_{1,2}$ <b>DC:</b> $D^{(1)} (\pm 20 \text{ mA}; \pm 1 \text{ V}; \pm 10 \text{ V})$ <b>ER:</b> B <b>THD:</b> THD (%) <b>Harm:</b> $U, I$ up to 50. <b>V<sub>Dip</sub>:</b> threshold violation <b>Flicker</b>

1) Root mean square values



## Selection and ordering data

Description	Order No.
<i>SIMEAS RV3.0 central unit ZE8/16 with integrated Ethernet port</i>	7KE6000-0□□□□ - □□□□
With one slot for data acquisition unit (DAU); ½ x 19" rack	
<i>Housing</i>	
For panel flush mounting (perforated housing)	D
For surface mounting (perforated housing)	E
For 19" assembly (perforated housing)	F
<i>Measurement at</i>	
16.7 Hz network	C
50 Hz network	D
60 Hz network	E
<i>Communication Port to a DAKON or evaluation PC</i>	
Standard: Ethernet & COM1 Port	4
<i>Terminals</i>	
Standard	1
US design (not possible with surface mounting housing)	2
<i>Signal voltages of the CPU and the binary inputs</i>	
24 V DC	1
48 - 60 V DC	2
110 - 125 V DC	3
220 - 250 V DC	4
48 - 60 V DC, control input 1 24 V DC <sup>1)</sup>	5
110 - 125 V DC, control input 1 24 V DC <sup>1)</sup>	6
220 - 250 V DC, control input 1 24 V DC <sup>1)</sup>	7
<i>Data acquisition unit DAU</i>	
VDAU ( 8 U / 16 binary inputs)	A
CDAU (8 I / 16 binary inputs)	B
VCDAU (4 U / 4 I / 16 binary inputs)	C
BDAU (32 binary inputs)	D
DDAU 20 mA	F
DDAU 1 V	G
DDAU 10 V	H
<i>Auxiliary power</i>	
24 to 60 V DC without battery	G
24 to 60 V DC with battery	H
50/60 Hz, 115/230 V AC or 110 V to 250 V DC without battery	J
50/60 Hz, 115/230 V AC or 110 V to 250 V DC with battery	K
<i>Manual</i>	
German	1
English	2
French	3
Spanish	4
Italian	5
Portuguese	7

1) For connecting a synchronization unit 7KE6000-8HA.. the control input 1 of the CPU has to be dimensioned for 24 V DC.

## Selection and ordering data

Description	Order No.
<b>SIMEAS R-PMU</b>	<b>7KE6100-0□□□□ - □□□□</b>
With one slot for data acquisition unit (DAU); ½ x 19" rack	
<b>Housing</b>	
For panel flush mounting (perforated housing)	D
For surface mounting (perforated housing)	E
For 19" assembly (perforated housing)	F
<b>Measurement at</b>	
50 Hz network	D
60 Hz network	E
<b>Communication Port to a DAKON or evaluation PC</b>	
Standard: Ethernet & COM1 Port	4
<b>Terminals</b>	
Standard	1
US design (not possible with surface mounting housing)	2
<b>Signal voltages of the CPU and the binary inputs</b>	
24 V DC	1
48 - 60 V DC	2
110 - 125 V DC	3
220 - 250 V DC	4
48 - 60 V DC, control input 1 24 V DC <sup>1)</sup>	5
110 - 125 V DC, control input 1 24 V DC <sup>1)</sup>	6
220 - 250 V DC, control input 1 24 V DC <sup>1)</sup>	7
<b>Data acquisition unit DAU</b>	
VDAU ( 8 U / 16 binary inputs)	A
CDAU (8 I / 16 binary inputs)	B
VCDAU (4 U / 4 I / 16 binary inputs)	C
BDAU (32 binary inputs)	D
DDAU 20 mA	F
DDAU 1 V	G
DDAU 10 V	H
<b>Auxiliary power</b>	
24 to 60 V DC without battery	G
24 to 60 V DC with battery	H
50/60 Hz, 115/230 V AC or 110 V to 250 V DC without battery	J
50/60 Hz, 115/230 V AC or 110 V to 250 V DC with battery	K
<b>Manual</b>	
German	1
English	2
French	3
Spanish	4
Italian	5

1) For connecting a synchronization unit 7KE6000-8HA.. the control input 1 of the CPU has to be dimensioned for 24 V DC.

## Selection and ordering data

Description	Order No.
<i>SIMEAS RV3.0 central unit ZE32/64 with integrated Ethernet port</i>	7KE6000-1□□□□ - □□□□
With four (4) slots for data acquisition units (DAUs); 19" rack	
<i>Housing</i>	
For panel flush mounting (perforated housing)	D
For surface mounting (perforated housing) <sup>1)</sup>	E
For 19" assembly (perforated housing)	F
<i>Measurement at</i>	
16.7 Hz network	C
50 Hz network	D
60 Hz network	E
<i>Communication Port to a DAKON or evaluation PC</i>	
Standard: Ethernet & COM1 Port	4
<i>Terminals</i>	
Standard	1
US design (not possible with surface mounting housing)	2
<i>Signal voltages of the CPU and the binary inputs for units without free assembly of the DAUs</i>	
24 V DC	1
48 - 60 V DC	2
110 - 125 V DC	3
220 - 250 V DC	4
48 - 60 V DC, control input 1 24 V DC <sup>2)</sup>	5
110 - 125 V DC, control input 1 24 V DC <sup>2)</sup>	6
220 - 250 V DC, control input 1 24 V DC <sup>2)</sup>	7
<i>Data acquisition unit DAU</i>	
Note: The fitting of the DAUs is from left to right	
VCDAU; 2 units ( 8 U / 8 I / 32 binary inputs)	A
VCDAU; 4 units (16 U / 16 I / 64 binary inputs)	B
VCDAU; 1 unit (4 U / 4 I / 16 binary inputs) and CDAU; 3 units (24 I / 48 binary inputs)	C
Data acquisition units (DAUs) for free assembly	D
Note: You need to select the required DAU units according to the 7KE6000-4** instructions. By these instructions, the type of the data acquisition units and the binary inputs will be defined.	
<i>Auxiliary power</i>	
24 to 60 V DC without battery	G
24 to 60 V DC with battery	H
50/60 Hz, 115/230 V AC or 110 V to 250 V DC without battery	J
50/60 Hz, 115/230 V AC or 110 V to 250 V DC with battery	K
<i>Manual</i>	
German	1
English	2
French	3
Spanish	4
Italian	5
Portuguese	7

- 1) The number of the possible measuring channels of surface mounting must be evaluated by the factory.
- 2) For connecting a synchronization unit 7KE6000-8HA.. the control input 1 of the CPU has to be dimensioned for 24 V DC.

## Selection and ordering data

Description	Order No.
<b>SIMEAS R-PMU</b>	<b>7KE6100-1□□□□ - □□□□</b>
With four (4) slots for data acquisition units (DAUs); 19" rack	
<b>Housing</b>	
For panel flush mounting (perforated housing)	D
For surface mounting (perforated housing) <sup>1)</sup>	E
For 19" assembly (perforated housing)	F
<b>Measurement at</b>	
50 Hz network	D
60 Hz network	E
<b>Communication Port to a DAKON or evaluation PC</b>	
Standard: Ethernet & COM1 Port	4
<b>Terminals</b>	
Standard	1
US design (not possible with surface mounting housing)	2
<b>Signal voltages of the CPU and the binary inputs for units without free assembly of the DAUs</b>	
24 V DC	1
48 - 60 V DC	2
110 - 125 V DC	3
220 - 250 V DC	4
48 - 60 V DC, control input 1 24 V DC <sup>2)</sup>	5
110 - 125 V DC, control input 1 24 V DC <sup>2)</sup>	6
220 - 250 V DC, control input 1 24 V DC <sup>2)</sup>	7
<b>Data acquisition unit DAU</b>	
Note: The fitting of the DAUs is from left to right	
VCDAU; 2 units ( 8 U / 8 I / 32 binary inputs)	A
VCDAU; 4 units (16 U / 16 I / 64 binary inputs)	B
VCDAU; 1 unit (4 U / 4 I / 16 binary inputs) and CDAU; 3 units (24 I / 48 binary inputs)	C
Data acquisition units (DAUs) for free assembly	D
Note:	
You need to select the required DAU units according to the 7KE6000-4** instructions.	
By these instructions, the type of the data acquisition units and the binary inputs will be defined.	
<b>Auxiliary power</b>	
24 to 60 V DC without battery	G
24 to 60 V DC with battery	H
50/60 Hz, 115/230 V AC or 110 V to 250 V DC without battery	J
50/60 Hz, 115/230 V AC or 110 V to 250 V DC with battery	K
<b>Manual</b>	
German	1
English	2
French	3
Spanish	4
Italian	5

1) The number of the possible measuring channels of surface mounting must be evaluated by the factory.

2) For connecting a synchronization unit 7KE6000-8HA.. the control input 1 of the CPU has to be dimensioned for 24 V DC.



## Selection and ordering data

Description	Order No.
<i>SIMEAS R assembly of the central unit ZE32/64<sup>1)</sup></i>	<i>7KE6000-4□□66-6□□0</i>
Also available for 7KE6000-1 and 7KE6100-1	
<i>Slot 1</i>	
VCDAU to be equipped in the factory <sup>2)</sup>	J
CDAU to be equipped in the factory <sup>2)</sup>	K
VDAU to be equipped in the factory <sup>2)</sup>	L
BDAU to be equipped in the factory <sup>2)</sup>	M
DDAU to be equipped in the factory <sup>2)</sup>	N
– not prepared / plate only	P
VCDAU prepared for a VCDAU for future use	Q
CDAU prepared for a CDAU for future use	R
VDAU prepared for a VDAU for future use	S
BDAU prepared for a BDAU for future use	T
DDAU prepared for a DDAU for future use	U
<i>Slot 2</i>	
VCDAU to be equipped in the factory <sup>2)</sup>	A
CDAU to be equipped in the factory <sup>2)</sup>	B
VDAU to be equipped in the factory <sup>2)</sup>	C
BDAU to be equipped in the factory <sup>2)</sup>	D
DDAU to be equipped in the factory <sup>2)</sup>	E
– not prepared / plate only	F
VCDAU prepared for a VCDAU for future use	G
CDAU prepared for a CDAU for future use	H
VDAU prepared for a VDAU for future use	J
BDAU prepared for a BDAU for future use	K
DDAU prepared for a DDAU for future use	L
<i>Slot 3</i>	
VCDAU to be equipped in the factory <sup>2)</sup>	A
CDAU to be equipped in the factory <sup>2)</sup>	B
VDAU to be equipped in the factory <sup>2)</sup>	C
BDAU to be equipped in the factory <sup>2)</sup>	D
DDAU to be equipped in the factory <sup>2)</sup>	E
– not prepared / plate only	F
VCDAU prepared for a VCDAU for future use	G
CDAU prepared for a CDAU for future use	H
VDAU prepared for a VDAU for future use	J
BDAU prepared for a BDAU for future use	K
DDAU prepared for a DDAU for future use	L
<i>Slot 4</i>	
VCDAU to be equipped in the factory <sup>2)</sup>	A
CDAU to be equipped in the factory <sup>2)</sup>	B
VDAU to be equipped in the factory <sup>2)</sup>	C
BDAU to be equipped in the factory <sup>2)</sup>	D
DDAU to be equipped in the factory <sup>2)</sup>	E
– not prepared / plate only	F
VCDAU prepared for a VCDAU for future use	G
CDAU prepared for a CDAU for future use	H
VDAU prepared for a VDAU for future use	J
BDAU prepared for a BDAU for future use	K
DDAU prepared for a DDAU for future use	L

1) Please apply only for free fitting.  
The central unit includes 4 slots for free fitting with data acquisition units (DAUs). Preparation of the slots with the corresponding terminals and fitting with DAUs.

2) Please specify and order the unit 7KE6000-2.

## Selection and ordering data

Description	Order No.
<i>SIMEAS R, data acquisition units for free fitting of the central unit ZE32/64 or as spare parts</i>	7KE6000 - 2□□□□
Also available for 7KE6000-0; 7KE6100-0; 7KE6000-1; 7KE6100-1	
VDAU (8 U / 16 binary inputs)	A
CDAU (8 I / 16 binary inputs)	B
VCDAU (4 U / 4 I / 16 binary inputs)	C
BDAU (32 binary inputs)	D
<i>Signal voltages of the binary inputs</i>	
24 V DC	A
48 to 60 V DC	B
110 to 125 V DC	C
220 to 250 V DC	D
<i>Terminals</i>	
Standard	1
US design	2
Without terminals as the central unit is already equipped with terminals	3
<i>System frequency</i>	
No frequency information in case of order number position 9 = D	0
16.7 Hz (not for 7KE6100-0 and 7KE6100-1)	1
50 Hz	2
60 Hz	3
<i>SIMEAS R, acquisition units for free fitting or as spare parts</i>	
	7KE6000 - 2□□□□
Also available for 7KE6000-0; 7KE6100-0; 7KE6000-1; 7KE6100-1	
DDAU (8 DC / 16 binary inputs)	E
<i>Terminals</i>	
Standard	A
US design	B
Without terminals, as the central unit is already equipped with terminals	C
<i>Analog channels</i>	
20 mA	1
1 V	2
10 V	3
<i>Signal voltages for binary inputs</i>	
24 V	1
48 to 60 V DC	2
110 to 125 V DC	3
220 to 250 V DC	4

## Selection and ordering data

Description	Order No.
<i>SIMEAS R Spare parts</i>	
<i>Spare flash memory for CPU-486 with firmware 2.1.xx<sup>1)</sup></i>	
PCMCIA Flash memory with PC card format and firmware 2.1.xx <sup>1)</sup> with standard parameterization	<i>7KE6000-3HA</i>
<i>Spare flash memory for CPU-486 with firmware 2.3.xx<sup>2)</sup></i>	
PCMCIA Flash memory with PC card format with pre-installed firmware 2.3.xx <sup>2)</sup> with additional functions „recording of flicker and voltage sags“ with <u>standard</u> parameterization Valid only for units with RAM memory of 32 MB Further information on our Web site: <a href="http://www.powerquality.de">http://www.powerquality.de</a>	<i>7KE6000-3HB</i>
<i>512 MB Flash memory for ELAN CPU + firmware 3.0.xx</i>	
IDE flash memory 2.5" and firmware 3.0.xx with standard parameterization Further information on our Web site: <a href="http://www.powerquality.de">http://www.powerquality.de</a>	<i>7KE6000-3HC1</i>
<i>Spare Memory Card 1 GB for ELAN CPU + firmware 4.0.xx (PMU)</i>	
IDE flash memory 2.5" and firmware 4.0.xx with standard parameterization	<i>7KE6100-3HC3</i>

1) Current version of firmware 2.1

2) Current version of firmware 2.3

## Selection and ordering data

Description	Order No.
<b>SIMEAS R V3.0 Spare parts</b>	
<i>Central processor unit (ELAN-CPU)</i>	7KE6000 - 2L□□
<i>Mass storage and firmware</i> With 512 MB IDE-flash memory 2.5" format and current firmware with standard parameterization	1
<i>Input signal voltage</i>	
24 V DC	A
48 to 60 V DC	B
110 to 125 V DC	C
220 to 250 V DC	D
48 to 60 V DC, control input 1 DC 24 V (see note)	E
110 to 125 V DC, control input 1 DC 24 V (see note)	F
220 to 250 V DC, control input 1 DC 24 V (see note)	G
Note: The control input 1 of CPU has to be dimensioned for 24 V DC on connection of the 7KE6000-8HA** synchronization box.	
<i>Power supply for central processor unit</i>	7KE6000-2G□
24 to 60 V DC without battery	G
24 to 60 V with battery	H
50/60 Hz, 115/230 V AC or 110 to 250 V DC without battery	J
50/60 Hz, 115/230 V AC or 110 to 250 V DC with battery	K
<i>Modems</i>	7KE6000-2J□
Analog modem, external	D
ISDN modem, external	F
<b>SIMEAS R-PMU Spare parts</b>	
<i>Central processor unit (ELAN-CPU)</i>	7KE6100 - 2L□□
<i>Mass storage and firmware</i> With 1 GB IDE-flash memory 2.5" format and current firmware with standard parameterization	1
<i>Input signal voltage</i>	
24 V DC	A
48 to 60 V DC	B
110 to 125 V DC	C
220 to 250 V DC	D
48 to 60 V DC, control input 1 DC 24 V (see note)	E
110 to 125 V DC, control input 1 DC 24 V (see note)	F
220 to 250 V DC, control input 1 DC 24 V (see note)	G
Note: Connection of a sync-box for SIMEAS R-PMU is not possible.	

## Selection and ordering data

Description	Order No.
<b>Synchronization unit</b> <sup>1)</sup>	<b>7KE6000 - 8HA□□</b>
In housing with snap-on attachment for 35 mm top-hat rail according to EN 50 022 with connection cable for ZE (central unit)	
<b>Receiver/decoder module</b>	
Decoder for DCF77 signal (to connect to a GPS receiver with DCF77 output signal f. example to a HOPF 6875 GPS receiver. This is the best choice for all applications worldwide)	2
Decoder for Meinberg or ZERA signal	3
Decoder for Patek - Philippe signal	4
Decoder for IRIG B signal (e.g. of GPS receiver) <sup>2)</sup>	5
Decoder for telenorma signal	6
Decoder for demodulated IRIG B signal, TTL level	7
Decoder for demodulated DCF77 signal, open collector connection	8
<b>Auxiliary power</b>	
24 to 60 V DC	1
110 to 250 V DC or 115 to 230 V AC 50/60 Hz	2
<b>GPS-time synchronization unit</b>	<b>7XV5664 - 0AA00</b>
with GPS-antenna and 25 m antenna cable time-receiver with 2 optical outputs (programable) ST-plugs for 62.5/125 μm multi-mode fibre. Output: IRIG-B or DCF77 time telegram auxiliary voltage 24 – 48 V DC for other auxiliary voltage ranges 7XV5810-0BA00 is required	
<b>DC-AC/DC converter</b>	<b>7XV5810 - 0□A00</b>
Input: 24 – 250 V DC, 115/230 V AC Output: 24 V DC	B
<b>Rugged switch RSG2100</b>	<b>7KE6000 - 8AP□0 - □AB</b>
12 x 10BaseFL ports with ST plug 2 x 100BaseFX ports 2 x 10/100BaseFT ports with RJ45 plug (uplink function)	
<b>Power supply</b>	
24 V DC	0
48 V DC	1
88 to 300 V DC or 85 to 264 V AC	2
<b>FO option for 2x100BaseFX ports</b>	
1310 nm, multi-mode, 2 km with ST plug	0
1310 nm, single mode, 15 km with LC plug	1
<b>Components for Ethernet communication</b>	
<b>HUB LV</b> <sup>3)</sup>	<b>7KE6000-8AD</b>
<b>HUB HV</b> <sup>4)</sup>	<b>7KE6000-8AE</b>
<b>Transceiver LV</b> <sup>3)</sup>	<b>7KE6000-8AF</b>
<b>Transceiver HV</b> <sup>4)</sup>	<b>7KE6000-8AG</b>
<b>Components for time synchronization</b>	
<b>Sync.-FO cable converter LV</b> <sup>3)</sup>	<b>7KE6000-8AH</b>
<b>Sync.-FO cable converter HV</b> <sup>4)</sup>	<b>7KE6000-8AJ</b>
<b>Sync.-transceiver LV</b> <sup>3)</sup>	<b>7KE6000-8AK</b>
<b>Sync.-transceiver HV</b> <sup>4)</sup>	<b>7KE6000-8AL</b>

1) For connecting a synchronization unit 7KE6000-8HA.. the control input 1 of the CPU has to be dimensioned for 24 V DC.

2) The IRIG-B signal has the following disadvantages: the year is not indicated, there is no switchover for daylight saving time, there is no relative time (not orientated towards time zones). It is strongly recommended to use a GPS receiver with a DCF77 output. The DCF77 signal can then be adapted to the DCF77 signal for SIMEAS R and DAKON via a synchronisation box.

3) LV  $\triangleq$  24 - 60 V DC

4) HV  $\triangleq$  110 - 230 V DC/AC, 45 - 65 Hz

## Selection and ordering data

Description	Order No.
<i>Communication cable COM1 - to external modem</i> Modem side 25-pole / pin, length 10 m	7KE6000-8AC
<i>Communication cable COM1 to PC</i> Incl. adapter set	7KE6000-8B <input type="checkbox"/>
COM1 or 2 - PC, length 10 m	A
COM1 or 2 - PC, length 5 m	B
<i>Printer cable, Centronics</i> Length 3 m, ZE or PC - printer	7KE6000-8DA
<i>Ethernet patch cable with double shield (SFTP), LAN connector on both sides SIMEAS R ↔ HUB, HUB ↔ PC</i>	
Length 0.5 m	7KE6000-8GD00-0AA5
Length 1 m	7KE6000-8GD00-1AA0
Length 2 m	7KE6000-8GD00-2AA0
Length 3 m	7KE6000-8GD00-3AA0
Length 5 m	7KE6000-8GD00-5AA0
Length 10 m	7KE6000-8GD01-0AA0
Length 15 m	7KE6000-8GD01-5AA0
Length 20 m	7KE6000-8GD02-0AA0
<i>Ethernet patch cable with double shield (SFTP), cross-over connection, LAN connector on both sides HUB ↔ HUB, SIMEAS R ↔ PC</i>	
Length 0.5 m	7KE6000-8GE00-0AA5
Length 1 m	7KE6000-8GE00-1AA0
Length 2 m	7KE6000-8GE00-2AA0
Length 3 m	7KE6000-8GE00-3AA0
Length 5 m	7KE6000-8GE00-5AA0
Length 10 m	7KE6000-8GE01-0AA0
Length 15 m	7KE6000-8GE01-5AA0
Length 20 m	7KE6000-8GE02-0AA0



## Selection and ordering data

Description	Order No.
<i>Connection cable for current inputs</i> 8-core flexible cable, 2.5 mm <sup>2</sup> , for 4 current channels Please note: Minimum length 2 m	7KE6000-8GA00-0□□□
Without pre-assembled cables	A
With end sleeve ferrule	B
With end sleeve ferrule on both sides	C
Without core identification	A
With core identification	B
Cable length in m (X = 2 ... 8, 9 = special length)	X
<i>Connection cable for voltage inputs</i> 8-core flexible cable, 0.75 mm <sup>2</sup> , for 4 voltage channels Please note: Minimum length 2 m	7KE6000-8GB00-0□□□
Without pre-assembled cables	A
With end sleeve ferrule on one side	B
With end sleeve ferrule on both sides	C
Without core identification	A
With core identification	B
Cable length in m (X = 2 ... 8, 9 = special length)	X
<i>Connection cable for binary inputs</i> 32-core flexible cable, 0.25 mm <sup>2</sup> Please note: Minimum length 2 m	7KE6000-8GC00-0□□□
Without pre-assembled cables	A
With end sleeve ferrule on one side	B
With end sleeve ferrule on both sides	C
Without core identification	A
With core identification	B
Cable length in m (X = 2 ... 8, 9 = special length)	X
<i>Manual</i>	
<i>for firmware version 3.xx</i>	
English	E50417-B1076-C209-A2
German	E50417-B1000-C209-A4
French	E50417-B1077-C209-A1
Spanish	E50417-B1078-C209-A1
Italian	E50417-B1072-C209-A1
Portuguese	E50417-B1079-C209-A1
<i>for firmware version PMU (V4)</i>	
English	E50417-B1076-C360-A1
German	E50417-B1000-C360-A1
French	E50417-B1077-C360-A2
Spanish	E50417-B1078-C360-A2
Italian	E50417-B1072-C360-A2

## Selection and ordering data

Description	Order No.
<p><b>DAKON XP (SIMATIC Rack PC)</b></p> <p>PENTIUM 4 / 2,4 GHz / 533 MHz FSB            512 MB DDR SDRAM (1 X 512 MB)            RAID1 2 x 60 GB EIDE HDD (removable &amp; mirrored hard disk)            1,44 MB FDD            CD-R/W            AGP-graphics card            2 x LAN (RJ45)            4 x Serial ports (COM1 - COM4) + 5 COM ports on an additional card            1 x Parallel port (LPT)            2 x USB 2.0 port (front)            2 x USB 2.0 port (rear)            2 x PS/2 port            6 x PCI / 4 free slots            Temperature &amp; fan monitoring            Power supply 110/230 V AC            European power connector            WINDOWS XP Professional Multi Language (EN, DE, FR, IT, SP), SP2</p> <p><u>Attention:</u>            OSCOP P is not included and must be ordered separately.            DAKON XP is only available with AC power supply</p>	<p><b>7KE6020-0BB00</b></p>
<p><b>USB Alarm Box</b></p> <p>Monitoring unit for DAKON XP with USB connection,            own watchdog and 7 alarm contacts</p>	<p><b>7KE6020-1AA00</b></p>

Dimension drawings in mm / inch

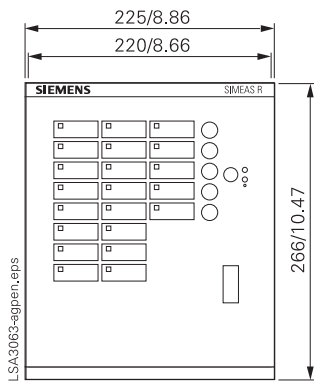

Front view

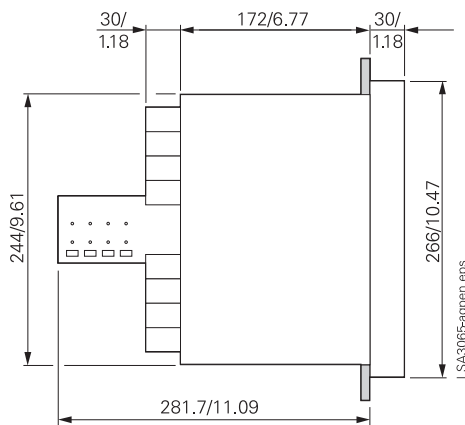

Side view

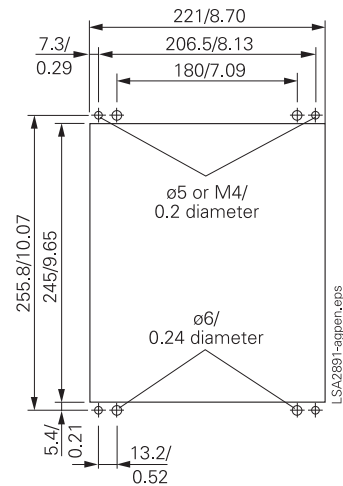

Panel cutout

Fig. 17/40

7KE6000 SIMEAS R  
1/2 x 19" with 7XP20 housing for panel flush mounting

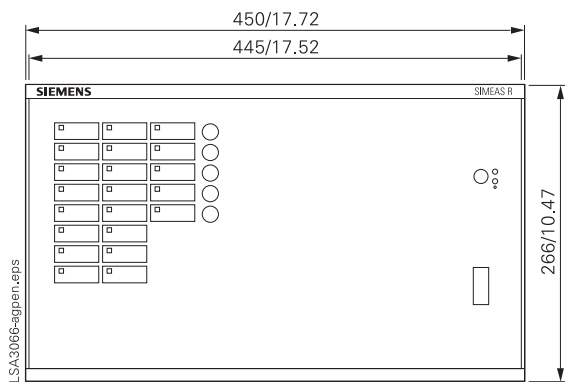

Front view

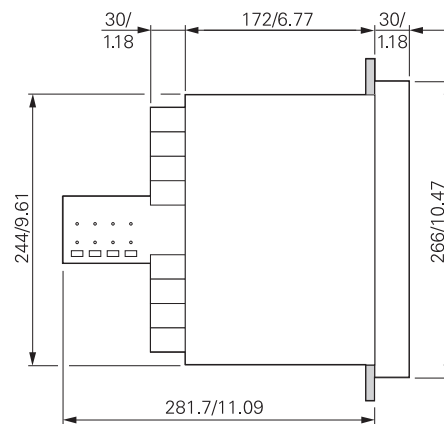

Side view

Fig. 17/41

7KE6000-1 SIMEAS R  
1/1 x 19" unit in 7XP20 housing  
for panel flush mounting

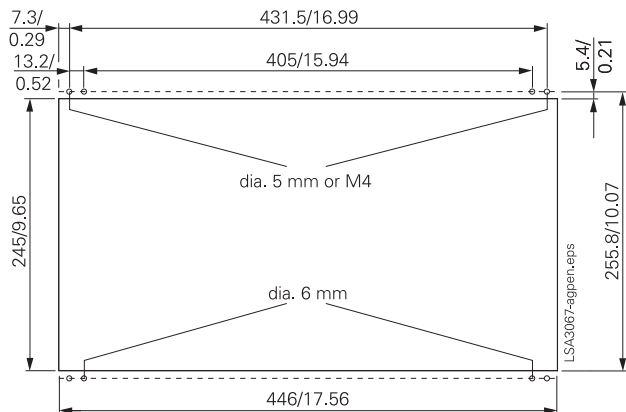

Panel cutout

Dimension drawings in mm / inch

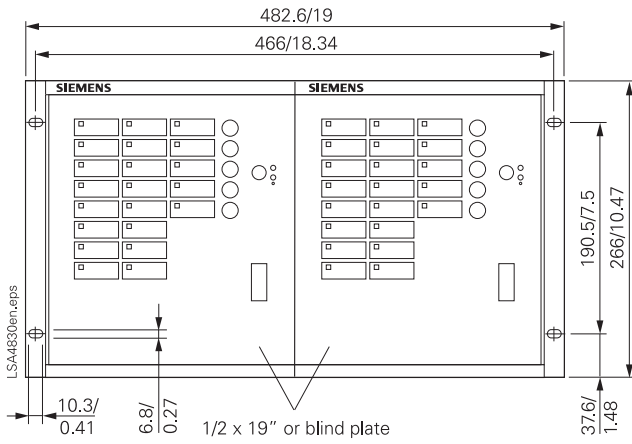

Front view

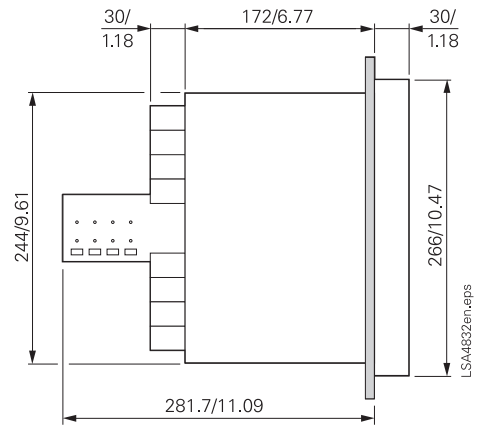

Side view

**Fig. 17/42**

7KE6000-0 SIMEAS R V3.0 / 7KE6100-0 SIMEAS R-PMU  
19" frame mounting

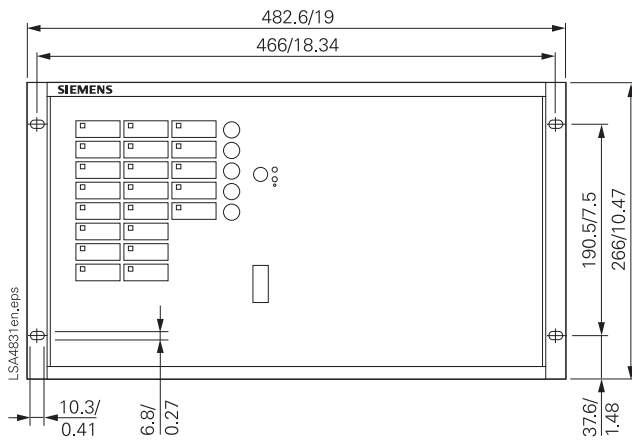

Front view

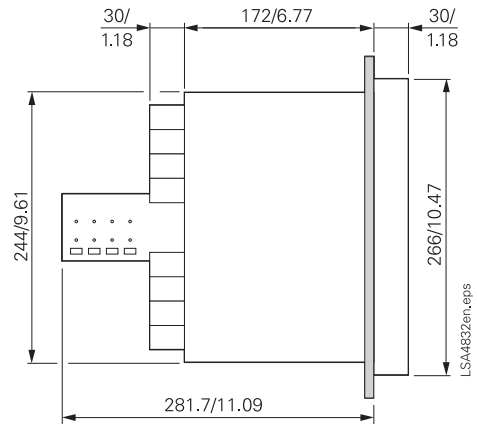

Side view

**Fig. 17/43**

7KE6000-0 SIMEAS R V3.0 / 7KE6100-0 SIMEAS R-PMU  
19" frame mounting

## Notes

---

If not stated otherwise on the individual pages of this catalog, we reserve the right to include modifications, especially regarding the stated values, dimensions and weights.

Drawings are not binding.

All product designations used are trademarks or product names of Siemens AG or other suppliers.

If not stated otherwise, all dimensions in this catalog are given in mm.

Responsible for

Technical contents:

Erik Pfähler / Saša Desnica  
Siemens AG  
Energy Sector, PTD EA 13  
Nuernberg

General editing:

Siemens AG  
Energy Sector, E CC MCC R  
Erlangen

---

**Siemens AG**  
Energy Sector  
Energy Automation  
Postfach 48 06  
90026 Nuernberg  
Germany

[www.siemens.com/simeas](http://www.siemens.com/simeas)  
[www.siemens.com/energy](http://www.siemens.com/energy)

For questions concerning  
Power Transmission and Distribution:  
You can contact our Customer Support  
Center 24 hours a day, 365 days a year.  
Tel.: +49 180/524 70 00  
Fax: +49 180/524 24 71  
(Charges depending on provider)  
E-Mail: [support.energy@siemens.com](mailto:support.energy@siemens.com)  
[www.siemens.com/energy-support](http://www.siemens.com/energy-support)

Subject to change without notice  
Order No.: E50001-K4400-B111-A1-7600  
Printed in Germany  
Dispo 31900  
KG 06.08 2.0 28 En  
103244 6101/13199