

# SIEMENS

## Panel Kit 800/1200A

Installation  
Instructions

# SENTRON HCP SWITCH CATALOG NO. F6162D



ITEM	DESCRIPTION	QTY.
1	MTG. BRKT.	1
2	MTG. BRKT.	1
3	INSULATION	1
4	LONG CONNECTOR	2
5	MIDDLE CONNECTOR	2
6	SHORT CONNECTOR	2
7	1-3/8" INSULATOR	3
8	3/8-16 X 3/4" HEX HEAD MACHINE SCREW	3
9	3/8" LOCKWASHER	3
10	3/8" FLAT WASHER	3
11	3/8-16 X 3/4" ROUND HEAD SQ. NECK BOLT	3
12	STRAP BUS HARDWARE KIT	2
13	1/4-28 X 3/8" SHWHWSW	4
14	5/16-18 THREADED INSERT	6
15	5/16-18 X 1" SLOTTED ROUND HEAD MACHINE SCREW	6
16	5/16 LOCKWASHER	6
17	5/16 FLAT WASHER	6
18	1/4-20 X 1" SLOTTED ROUND HEAD MACHINE SCREW	2
▲ 19	GROUND STRAP ASSEMBLY	1
20	10-32 X 1/4" HEX WASHER HEAD MACHINE SCREW	2

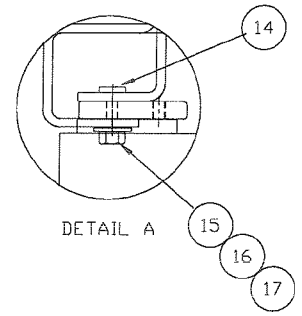
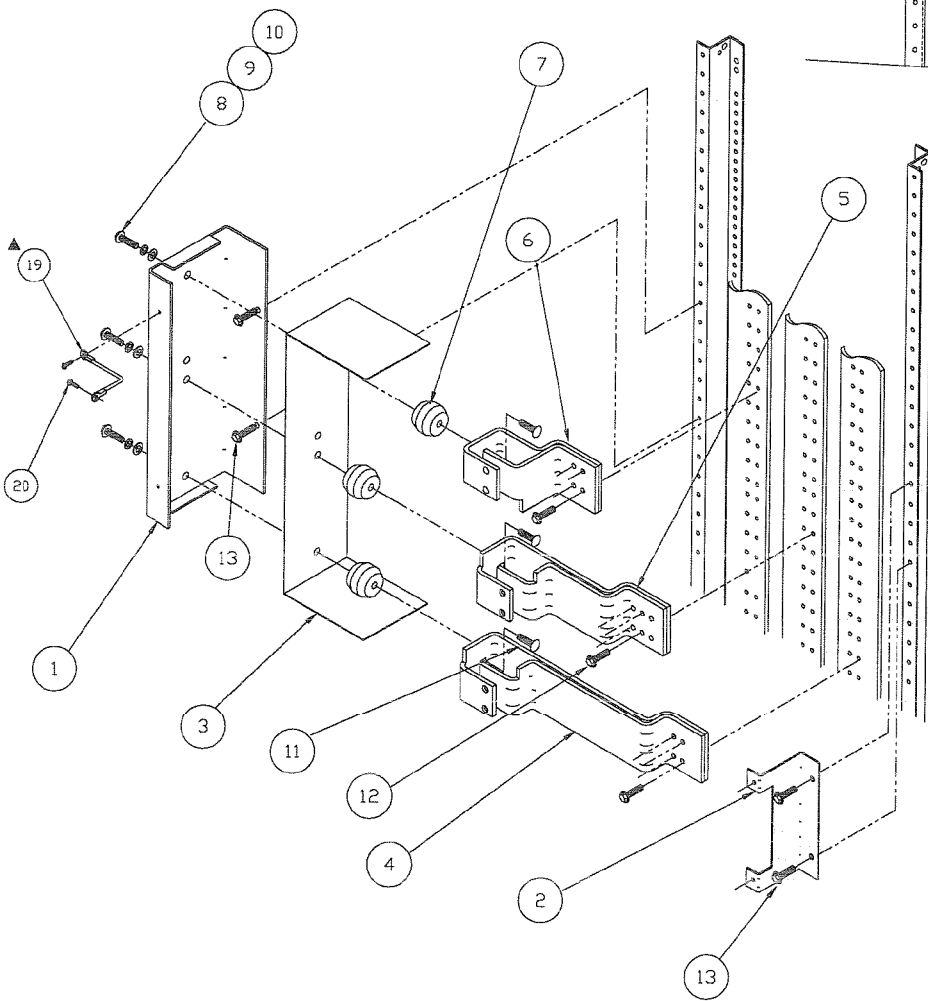
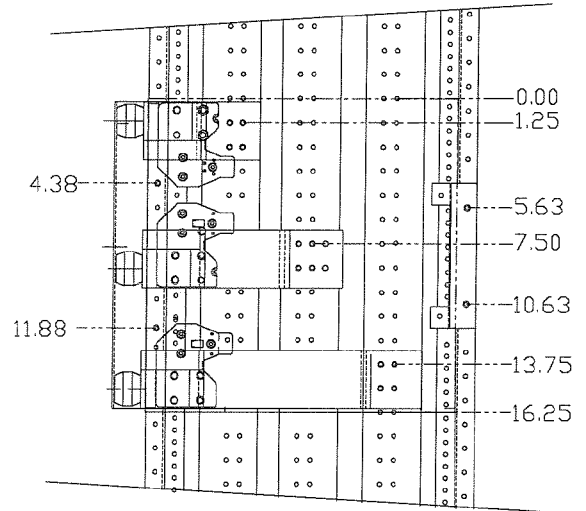
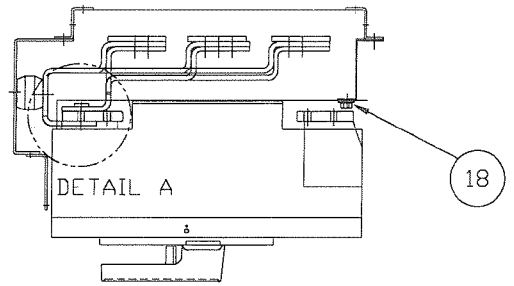

# Installation Instructions

The following instructions are for the installation of the Siemens Sentron type HCP switch rated 800 and 1200 amp in a Type S5, CDP6, SPP panelboard or FCI, FCII, SB1, SB2 and SB3 switchboard distribution sections. The kit may also be applied on other panels or switchboards. Consult your local Siemens sales office for information. The switch is not included with this kit and must be purchased separately. Be sure to choose the appropriate switch for the system in use.

	<b>! DANGER</b>
	<p>High voltage. Will cause severe injury or death. Only qualified personnel should work on this equipment. Lock off power supplying this equipment before working inside.</p>

This kit is good for the  
800 and 1200 amp - Sentron HCP switch

1. **For installation of a switch as a branch.** Only qualified personnel should work on this equipment. Disconnect and lock off all sources of electrical power supplying this equipment before working on it.

To install this kit, determine the location of the switch in the interior. 16.25 inches of clear, continuous space in the interior will be required. Measure the distance from the top dead front support to the beginning of the 16.25" space. After removal of the dead front, transfer this dimension to the interior "Z" rail, also measured from the dead front support. This location will be the 0.00" dimension shown in the orthographic assembly drawing.

Prior to assembling the connectors ( items 4, 5, & 6) to the section bus, assemble the threaded inserts (item 14) to each connector. This is accomplished by tapping the insert into the under-side of the connector with a hammer. Do not strike hard enough to damage the threads.

To assemble the connectors to the section bus note the dimensional drawing and attach with the screws provided in the connector hardware kits. The hardware used to attach the connectors varies due to the number of laminations of the bus bar in the interior. Using the wrong screws could reduce required clearances or cause a loose assembly leading to overheating or fires. Start but do not tighten the screws at this time.

2. **Attaching the switch supports:** Attach the switch supports (item 1 & 2) to the Z- rail as shown on the assembly drawing. Noting the dimension view place the supports on the Z- rail and attach with two 1/4-20 x 3/8 hex washer head thread forming screws (item 13) provided.

3. **Positioning the connectors:** Place the 3/8-16 x 3/4" carriage bolts (item 11) through the connectors, into the 1 3/8" insulators (item 7) and tighten the insulators

to the connectors. Position the insulation (item 3) between the support (item 1) and the 1 3/8" insulators. Using the 3/8-16 x 3/4" hex head bolts and 3/8" lock and flatwashers (item 8, 9, 10), secure the 1 3/8" insulators to the supports. Insure that the holes in the connectors are aligned. Tighten the screws left loose in step 2 that hold the connectors to the section bus. Torque all connections to the recommended torque values marked on the product.

4. **Attaching the switch:** Position the switch so that the connectors are above and below the stabs of the switch and the holes are aligned. Attach the switch to the connectors using the 5/16-18 x 1" hex head machine screws (item 15), 5/16" lockwashers (item 16) and 5/16" flatwashers (item 17). Leave these screws loose at this time.

Attach the switch to the support (item 2) using two 1/4-20 x 1" slotted round head machine screws (item 18). Tighten the 5/16" screws left loose above. Torque connections to values specified on the equipment.

5. **Grounding the switch:** It is important that the switch enclosure be electrically attached to the switchboard ground bus. To accomplish this, attach ground strap (item 19) to the connector support (item 1) and the switch enclosure with the #10-32 screws (item 20).
6. **Connect the cables to the switch and torque connections to values specified on the device or if no values are specified on the device refer to the installation and maintenance instruction affixed to the rear of the dead front of the panel or on labeling on the switchboard.**
7. **Re-assemble the dead front on the distribution section.**

