

Instructions

52-HMA4G

April, 2001
Supersedes 52-HMA5G Issue of
January, 2000

Compact Pilot Light
Class 52
52MA4G

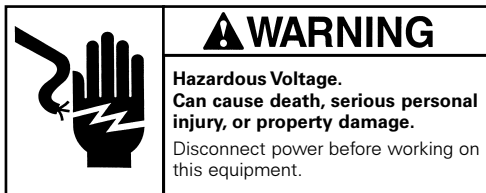
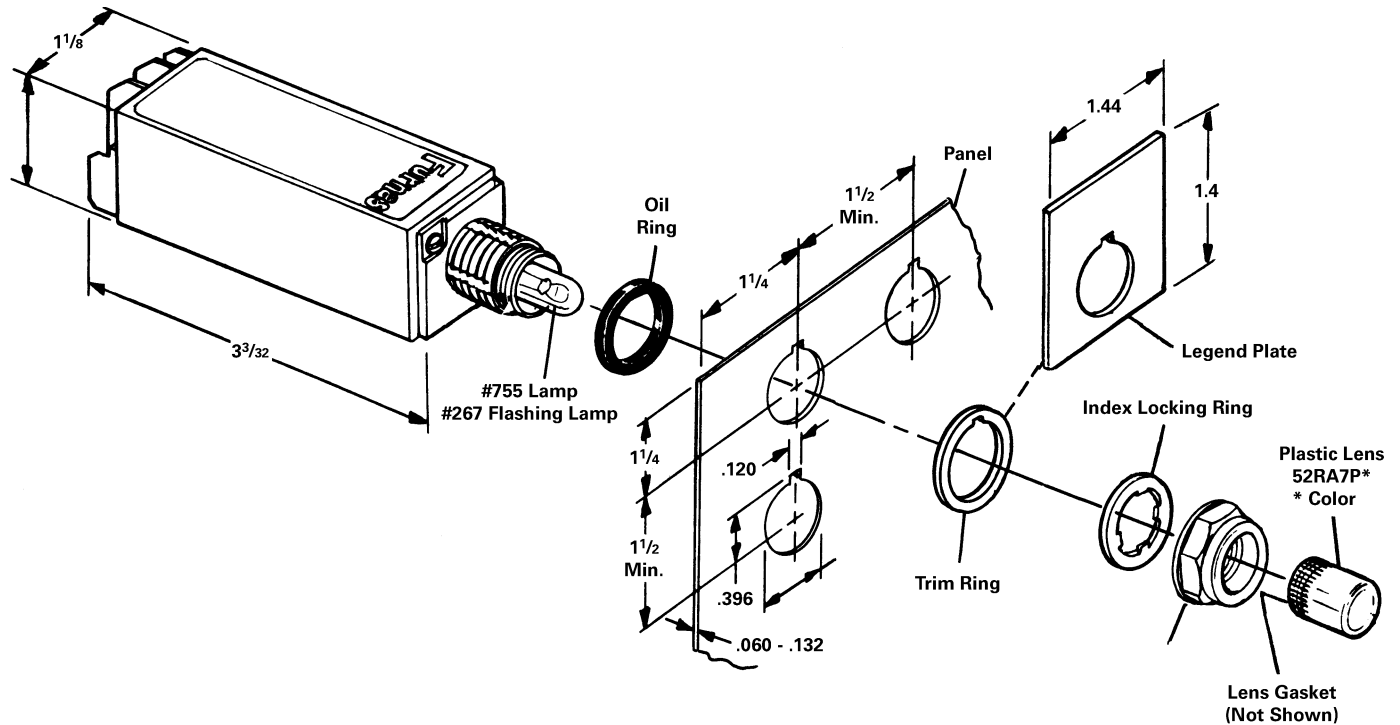

INSTALLATION

Units are assembled as shown

1. Assemble oil ring.
2. Mount unit on panel as shown in the illustration.
3. Position trim ring or legend plate (trim ring is discarded when legend plate is used).
4. Position index locking ring on unit as shown in illustration.
5. Assemble and tighten lock nut to 8 ft.-lbs.
6. Assemble lens to pilot light with lens gasket inside lens.

These instructions do not purport to cover all details or variations in equipment, nor to provide for every possible contingency to be met in connection with installation, operation or maintenance. Should further information be desired or should particular problems arise which are not covered sufficiently for the purchaser's purposes, the matter should be referred to the local Siemens sales office.

The contents of this instruction manual shall not become part of or modify any prior or existing agreement, commitment or relationship. The sales contract contains the entire obligation of Siemens. The warranty contained in the contract between the parties is the sole warranty of Siemens. Any statements contained herein do not create new warranties or modify the existing warranty.

(For Engineering Reference Only - Rev. A)