



3/2	Introduction
3/4	SIRIUS SC semiconductor switching devices General data
3/7	Semiconductor relays General data
3/8	22.5 mm semiconductor relays
3/13	45 mm semiconductor relays
3/16	Semiconductor contactors SIRIUS SC semiconductor contactors
3/25	Function modules General data
3/26	Converters
3/27	Load monitoring
3/28	Output regulators
3/29	Semiconductor relays and contactors, function modules Project planning aids

Introduction

Overview

Products at a glance



3RF21



3RF20



3RF23



3RW30/31



3RW34



	Order No.	Page
SIRIUS SC semiconductor switching devices		
Semiconductor relays		
22.5 mm semiconductor relays 45 mm semiconductor relays <ul style="list-style-type: none"> • Construction width of 22.5 mm and 45 mm • Compact and space-saving design • "Zero-point switching" version • Mounting onto existing heat sinks 	3RF21, 3RF20	3/12 3/15
Semiconductor contactors		
SIRIUS SC semiconductor contactors <ul style="list-style-type: none"> • Complete units consisting of a semiconductor relay and an optimized heat sink, "ready to use" • Compact and space-saving design • Versions for resistive loads "zero-point switching" and inductive loads "instantaneous switching" • Special designs "Low Noise" and "Short-Circuit Resistant" 	3RF23	3/22
Function modules		
Converters <ul style="list-style-type: none"> • The converter is used to convert an analog input signal to an on/off ratio 	3RF29 00-0EA18	3/26
Load monitors <ul style="list-style-type: none"> • Load monitoring of one or more loads (partial loads) 	3RF29	3/27
Output regulators <ul style="list-style-type: none"> • The output regulator supplies the current by means of a semiconductor switching device depending on a setpoint value. Closed-loop control: Full wave control or generalized phase control 	3RF29	3/28
SIRIUS/SIKOSTART soft starters		
For standard applications		
SIRIUS soft starters <ul style="list-style-type: none"> • SIRIUS 3RW30/31 soft starters for soft starting and smooth ramp-down of three-phase asynchronous motors • Service range <ul style="list-style-type: none"> - Pumps - Compressors - Conveyors 	3RW30, 3RW31	
SIKOSTART soft starters <ul style="list-style-type: none"> • SIKOSTART 3RW34 soft starters for soft starting and smooth ramp-down of three-phase asynchronous motors • Methods of connection <ul style="list-style-type: none"> - Inline circuit - Inside-delta circuit • Service range <ul style="list-style-type: none"> - Pumps - Compressors - Fans - Conveyors 	3RW34	

SIRIUS SC Semiconductor Switching Devices

General data

Overview

SIRIUS SC semiconductor switching devices

- Semiconductor relays
- Semiconductor contactors
- Function modules

SIRIUS SC – for almost unending activity

Conventional electromechanical switching devices are often overtaxed by the rise in the number of switching operations. A high switching frequency results in frequent failure and short replacement cycles. However, this does not have to be the case, because with the latest generation of our SIRIUS SC semiconductor switching devices we provide you with semiconductor relays and contactors with a particularly long service life – for almost unending activity even under the toughest conditions and under high mechanical load, but also in noise-sensitive areas.

Proved time and again in service

SIRIUS SC semiconductor switching devices have become firmly established in industrial use. They are used above all in applications where loads are switched frequently – mainly with resistive load controllers, with the control of electrical heat or the control of valves and motors in conveyor systems. In addition to its use in areas with high switching frequencies, thanks to its silent switching SIRIUS SC is also ideally suited to noise-sensitive areas such as offices or hospitals.

The most reliable solution for any application

Compared with mechanical switching devices, our SIRIUS SC semiconductor switching devices stand out because of their considerably higher service life. Thanks to the high product quality, their switching is extremely precise, reliable and above all unsusceptible to faults. With its variable connection methods and a wide spread of control voltages, the SIRIUS SC family is universally applicable. Depending on the individual requirements of the application, our modular switching devices can also be quite easily expanded by the addition of standardized function modules.

Always on the sunny side with SIRIUS SC

Because SIRIUS SC offers even more:

- The space-saving and compact side-by-side mounting ensure reliable operation up to an ambient temperature of +60 °C.
- Thanks to fast project planning and the ease of installation and start-up you save not only time but also expense.

Type	Semiconductor relays		Semiconductor contactors	Function modules			Power controllers
	22.5 mm	45 mm		Converters	Load monitors Basic	Extended	
Use							
Simple use of existing semiconductor relays	○	✓	○				
Complete "Ready to use"	○	○	✓				
Space-saving	✓		✓	✓	✓		
Can be extended with modular function modules	✓		✓				
Frequent switching and monitoring of loads and semiconductor relays/semiconductor contactors	✓		✓		✓	✓	
Monitoring of more than 6 partial loads	✓		✓			✓	
Control of the heating power via an analog input	✓		✓	✓			✓
Power control	✓		✓				✓
Mounting							
Mounting on standard mounting rail or mounting plate			✓				
Snapped directly onto semiconductor relay or contactor				✓	✓	✓	✓
For use with coolplate	✓	✓					
Cable routing							
Connection of load circuit as for controlgear	✓		✓				
Connection of load circuit from above		✓		✓	✓	✓	✓

- ✓ Function is available
○ Function is possible

Benefits

- Considerable space savings thanks to a width of only 22.5 mm
- Variety of connection techniques: screw connection, spring-type connection or ring terminal end, there is no problem - they are all finger-safe
- Flexible for all applications with function modules for retrofitting
- Possibility of fuseless short-circuit resistant design

Advantages:

- Saves time and costs with fast installation and commissioning, short setting-up times and easy wiring
- Extremely long life, low maintenance, rugged and reliable
- Space-saving and safe thanks to side-by-side mounting up to an ambient temperature of +60 °C
- Modular design: standardized function modules and heat sinks can be used in conjunction with semiconductor relays to satisfy individual requirements
- Safety due to lifelong, vibration-resistant and shock-resistant spring-loaded terminal connection system even under tough conditions

Area of application

Applications

Example plastic machine industry:

Thanks to their high switching endurance, SIRIUS SC semiconductor switching devices are ideally suited for use in the control of electroheat. This is because the more precise the temperature regulation process has to be, the higher the switching frequency. The accurate regulation of electroheat is used for example in many processes in the plastic machine industry:

- Band heaters heat the extrudate to the correct temperature in plastic extruders
- Heat emitters heat plastic blanks to the correct temperature
- Heat drums dry plastic granules
- Heating channels keep molds at the correct temperature in order to manufacture different plastic parts without defects.

The powerful SIRIUS SC semiconductor relays and contactors can be used to control several heating loads at the same time. By using a load monitoring module the individual partial loads can easily be monitored, and in the event of a failure a signal is generated to be sent to the controller.

Protecting the semiconductor relays and semiconductor contactors with miniature circuit-breakers (B MCB)

Short-circuit protection and line protection with miniature circuit-breakers is easy to achieve with SIRIUS SC semiconductor relays and semiconductor contactors in comparison with designing load feeders with fuses. A special version of the semiconductor contactors can be protected against damage in the case of a short-circuit with a miniature circuit-breaker with type B tripping characteristic. This allows the low-cost and simple design of fuseless load feeders with full protection of the switching device.

Design

There is no typical design of a load feeder with semiconductor relays or semiconductor contactors; instead, the great variety of connection systems and control voltages offers universal application opportunities. SIRIUS SC semiconductor relays and semiconductor contactors can be installed in fuseless or fused feeders, as required.

There are special versions with which it is even possible to achieve short-circuit strength in a fuseless design.

Functions

Connection

All SIRIUS SC semiconductor switching devices are characterized by the great variety of connection methods. You can choose between the following connection techniques:

SIGUT connection system

The SIGUT connection system is the standard among industrial switching devices. Open terminals and a plus-minus screw are just two features of this technology. Two conductors of up to 6 mm² can be connected in just one terminal. As a result, loads of up to 50 A can be connected.

Spring-loaded connection system

This innovative technology manages without any screw connection. This means that very high vibration resistance is achieved. Two conductors of up to 2.5 mm² can be connected to each terminal. As a result, loads of up to 20 A can be dealt with.

Ring terminal end connection

The ring terminal end connection is equipped with an M5 screw. Ring terminal ends of up to 25 mm² can be connected. In this way it is possible to connect even high powers with current intensities of up to 88 A safely. Finger safety is provided in this case too with a special cover.

Switching functions

In order to guarantee an optimized control method for different loads, the functionality of our semiconductor switching devices can be adapted accordingly.

The "**zero-point switching**" method has proved to be ideal for resistive loads, i.e. where the power semiconductor is activated at zero voltage.

For inductive loads, on the other hand, for example in the case of valves, it is better to go with "**instantaneous switching**". By distributing the ON point over the entire sine curve of the mains voltage, disturbances are reduced to a minimum.

Performance characteristics

The performance of the semiconductor switching devices is substantially determined by the type of power semiconductor used and the internal design. In the case of the SIRIUS SC semiconductor contactors and semiconductor relays, only thyristors are used in place of less powerful Triacs.

Two of the most important features of thyristors are the blocking voltage and the maximum load integral:

Blocking voltage

Thyristors with a high blocking voltage can also be operated without difficulty in power systems with high interference voltages. Separate protective measures, such as a protective circuit with a varistor, are not necessary in most cases.

With SIRIUS SC, for example, thyristors with 800 V blocking voltage are fitted for operation in power systems up to 230 V. Thyristors with up to 1600 V are used for power systems with higher voltages.

Maximum load integral

One of the purposes of specifying the maximum load integral (Pt) is to determine the rating of the short-circuit protection. Only a large power semiconductor with a correspondingly high Pt value can be given appropriate protection against destruction from a short-circuit by means of a protective device matched to the application. However, SIRIUS SC is also characterized by the optimum matching of the thyristors (Pt value) with the rated currents. The rated currents specified on the devices in conformance with EN 60947-4-3 were confirmed by extensive testing.

Further information is available on the Internet at:

www.siemens.de/siriussc

SIRIUS SC Semiconductor Switching Devices

General data

Further information

Notes on integration in the load feeders

The SIRIUS SC semiconductor switching devices are very easy to integrate into the load feeders thanks to their industrial connection technology and design.

Particular attention must however be paid to the circumstances of the installation and ambient conditions, as the performance of the semiconductor switching devices is largely dependent on these. Depending on the version, certain restrictions must be observed. Detailed information, for example in relation to semiconductor contactors about the minimum spacing and to semiconductor relays about the choice of heat sink, is given in the product data sheets and the technical specifications in the A&D Mall.

Despite the rugged power semiconductors that are used, semiconductor switching devices respond more sensitively to short-circuits in the load feeder. Consequently, special precautions have to be taken against destruction, depending on the type of design.

Siemens generally recommends using SITOP semiconductor protection fuses. These fuses also provide protection against destruction in the event of a short-circuit even when the semiconductor contactors and semiconductor relays are fully utilized.

Alternatively, if there is lower loading, protection can also be provided by standard fuses or miniature circuit-breakers. This protection is achieved by overdimensioning the semiconductor switching devices accordingly. The technical specifications in the A&D Mall and the product data sheets contains details both about the semiconductor fuse protection itself and about use of the SIRIUS SC devices with conventional protection equipment.

The SIRIUS SC semiconductor switching devices are suitable for interference-free operation in industrial power systems without further measures. If they are used in public power systems, it may be necessary for conducted interference to be reduced by means of filters. This does not include the special type 3RF23 20-.CA.. "low noise" semiconductor contactors. These comply with the class B limit values up to a rated current of 16 A. If other versions are used, and at currents of over 16 A, standard filters can be used in order to comply with the limit values. The decisive factors when it comes to selecting the filters are essentially the current loading and the other parameters (operational voltage, design type, etc.) in the load feeder.

Suitable filters can be ordered from EPCOS AG (see Appendix -> External Partners).
For more information go to www.epcos.com

Selection and ordering data

Accessories

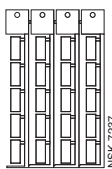
Designation	Labeling area/color	DT	Order No.	PS*	Weight per PU approx.
	W x H mm x mm				kg
Blank identification plates					
	Item code labels for "SIRIUS"¹⁾				
	10 x 7 pastel turquoise	D	3RT19 00-1SB10	816 units	0.030
	20 x 7 pastel turquoise	A	3RT19 00-1SB20	340 units	0.067
	"SIRIUS" labels for sticking				
19 x 6 pastel turquoise	D	3RT19 00-1SB60	4700 units	0.003	
19 x 6 zinc yellow	C	3RT19 00-1SD60	4700 units	0.003	

Item code labels
1 frame = 20 labels

1) Computer labeling system for individual labeling of item code labels available from:
murrplastik Systemtechnik GmbH (see Appendix -> External Partners).

SIRIUS SC Semiconductor Switching Devices

Semiconductor Relays

General data

Overview

Semiconductor relays

SIRIUS SC semiconductor relays are suitable for surface mounting on existing cooling surfaces. Installation is quick and easy, involving just two screws. The special technology of the power semiconductor ensures there is excellent thermal contact with the heat sink. Depending on the nature of the heat sink, the capacity reaches up to 88 A on resistive loads. The 3RF21 semiconductor relays can be expanded with various function modules to adapt them to individual applications.

The semiconductor relays are available in 2 different widths:

- 3RF21 semiconductor relay with a width of 22.5 mm
- 3RF20 semiconductor relay with a width of 45 mm

Both variants are only available in the "zero-point switching" version. This standard version is ideally suited for operation with resistive loads.

Further information

Notes on selection

These notes are intended for general orientation and will no doubt be sufficient for most applications. If the installation conditions differ significantly from the examples described here, you can contact our Technical Assistance team for further help.

Telephone: +49 9131 7 43833
Fax: +49 9131 7 42899
e-mail: nst.technical-assistance@siemens.com

For more information on the Internet go to
www.siemens.de/lowvoltage/technical-assistance

Selecting semiconductor relays

When selecting semiconductor relays, in addition to information about the power system, the load and the ambient conditions it is also necessary to know details of the planned design. The semiconductor relays can only conform to their specific technical specifications if they are mounted with appropriate care on an adequately dimensioned heat sink. The following procedure is recommended:

- Determine the rated current of the load and the mains voltage
- Select the relay design and choose a semiconductor relay with higher rated current than the load
- Determine the thermal resistance of the proposed heat sink
- Check the correct relay size with the aid of the diagrams

For more information on the Internet go to
www.siemens.com/siriussc

3

SIRIUS SC Semiconductor Switching Devices

Semiconductor Relays

22.5 mm semiconductor relays

Overview

22.5 mm semiconductor relays

With its compact design, which stays the same even at currents of up to 88 A, the 3RF21 semiconductor relay is the ultimate in space-saving construction, at a width of 22.5 mm. The logical connection arrangement, with the power infeed from above and connection of the load from below, ensures tidy installation in the control cabinet.

Technical specifications

Type		3RF21 ..-1....	3RF21 ..-2....	3RF21 ..-3....
General data				
Ambient temperature				
during operation, derating from 40 °C	°C	-25 ... +60		
when stored	°C	-55 ... +80		
Site altitude	m	0 ... 1000; derating from 1000		
Shock resistance	g/ms	15/11		
acc. to IEC 60068-2-27				
Vibration resistance	g	2		
acc. to IEC 60068-2-6				
Degree of protection		IP20		
Electromagnetic compatibility (EMC)				
Emitted interference				
• Conducted interference voltage		Class A for industrial applications		
acc. to IEC 60947-4-3				
• Emitted, high-frequency interference		Class A for industrial applications		
voltage acc. to IEC 60947-4-3				
Noise immunity				
• Electrostatic discharge	kV	Contact discharge 4; air discharge 8; behavior criterion 2		
acc. to IEC 61000-4-2				
(corresponds to degree of severity 3)				
• Induced RF fields acc. to IEC 61000-4-6	MHz	0.15 ... 80; 140 dBµV; behavior criterion 1		
• Burst acc. to IEC 61000-4-4	kV	2/5.0 kHz; behavior criterion 1		
• Surge acc. to IEC 61000-4-5	kV	Conductor - ground 2; conductor - conductor 1; behavior criterion 2		
Connection technique				
		Screw-type connection	Spring-loaded connection	Ring cable connection
Main contact connection				
Conductor cross-section				
Solid	mm ²	2 × (1.5 ... 2.5), 2 × (2.5 ... 6)	2 × (0.5 ... 2.5)	-
Finely stranded with end sleeve	mm ²	2 × (1.5 ... 2.5), 2 × (2.5 ... 6), 1 × 10	2 × (0.5 ... 1.5)	-
Finely stranded without end sleeves	mm ²		2 × (0.5 ... 2.5)	-
Solid or stranded AWG conductors	AWG	2 × (14 ... 10)	2 × (18 ... 14)	-
Insulation stripping length	mm	10	10	-
Terminal screw		M 4	-	M 5
• Tightening torque	Nm	2 ... 2.5	-	2 ... 2.5
	lb.in	18 ... 22	-	18 ... 22
Cable lug				
• DIN		-	-	DIN 46234
				-5-2.5, -5-6, -5-10, -5-16, -5-25
• JIS		-	-	JIS C 2805 R 2-5, 5.5-5, 8-5, 14-5
Auxiliary/control contact connections				
Conductor cross-section	mm ²	1x (0.5 ... 2.5); 2x (0.5 ... 1)	0.5 ... 1.5	1x (0.5 ... 2.5); 2x (0.5 ... 1)
	AWG	20 ... 12	20 ... 12	20 ... 12
Insulation stripping length	mm	7	10	7
Terminal screw		M 3	-	M 3
• Tightening torque	Nm	0.5 ... 0.6	-	0.5 ... 0.6
	lb.in	4.5 ... 5.3	-	4.5 ... 5.3
Main circuit				
Rated operational voltage U_e	V	24 ... 230	230 ... 460	400 ... 600
• Tolerance	%	-15 / +10		
• Rated frequency	Hz	50/60		
Rated insulation voltage U_i	V	600		
Blocking voltage	V	800	1200	1600
Rate of voltage rise	V/µs	1000		

SIRIUS SC Semiconductor Switching Devices

Semiconductor Relays

22.5 mm semiconductor relays

3

Order No.	$I_{\max}^{1)}$ at $R_{\text{thha}}/T_u = 40\text{ °C}$		I_e to IEC 60947-4-3 at $R_{\text{thha}}/T_u = 40\text{ °C}$		I_e to UL/CSA at $R_{\text{thha}}/T_u = 50\text{ °C}$		Power loss for I_{\max}	Minimum load current	Leakage current
	A	K/W	A	K/W	A	K/W			
Main circuit									
3RF21 20-.....	20	2.0	20	2.0	20	1.7	28.6	0.5	10
3RF21 30-1....	30	1.1	30	1.1	30	0.88	44.2	0.5	10
3RF21 50-1....	50	0.68	50	0.68	50	0.53	66	0.5	10
3RF21 50-2....	50	0.68	20	4.2	20	3.3	66	0.5	10
3RF21 50-3....	50	0.68	50	0.68	50	0.53	66	0.5	10
3RF21 70-1....	70	0.4	50	0.95	50	0.8	94	0.5	10
3RF21 90-1....	88	0.33	50	1.25	50	1.02	118	0.5	10
3RF21 90-2....	88	0.33	20	5.0	20	4.0	118	0.5	10
3RF21 90-3....	88	0.33	88	0.33	83	0.29	118	0.5	10

1) I_{\max} provides information about the performance of the semiconductor relay. The actual permitted operational current I_e can be smaller depending on the connection method and cooling conditions.

Order No.	Rated impulse withstand capacity I_{ISM}	I^2t value
Main circuit		
3RF21 20-.....	200	200
3RF21 30-..AA.2	300	450
3RF21 30-..AA.4	300	450
3RF21 30-..AA.6	400	800
3RF21 50-.....	600	1800
3RF21 70-..AA.2	1200	7200
3RF21 70-..AA.4	1200	7200
3RF21 70-..AA.6	1150	6600
3RF21 90-.....	1150	6600

Type		3RF21 ..-....0	3RF21 ..-....2
Control circuit			
Method of operation		DC operation	AC operation
Rated control supply voltage U_s	V	24 to EN 61131-2	110 ... 230
Max. rated control voltage	V	30	253
Rated control current at U_s	mA	15	6
Rated frequency of the control supply voltage	Hz	-	50/60
Response voltage for tripping current	V mA	15 2	90 2
Drop-out voltage	V	5	40
Operating times			
closing time	ms	1 additionally max. one half-wave	40 additionally max. one half-wave
opening time	ms	1 additionally max. one half-wave	40 additionally max. one half-wave

SIRIUS SC Semiconductor Switching Devices

Semiconductor Relays

22.5 mm semiconductor relays

3

Order No.	Accessories		
	Converters	Load monitors Basic	Extended
Type current = 20 A			
3RF21 2-1..02	3RF29 00-0EA18	3RF29 20-0FA08	3RF29 20-0GA13
3RF21 2-1..04	3RF29 00-0EA18	3RF29 20-0FA08	3RF29 20-0GA16
3RF21 2-1..22	-	-	3RF29 20-0GA33
3RF21 2-1..24	-	-	3RF29 20-0GA36
3RF21 2-2..02	3RF29 00-0EA18	-	-
3RF21 2-2..04	3RF29 00-0EA18	-	-
3RF21 2-3..02	3RF29 00-0EA18	-	3RF29 20-0GA13
3RF21 2-3..04	3RF29 00-0EA18	-	3RF29 20-0GA16
3RF21 2-3..22	-	-	3RF29 20-0GA33
3RF21 2-3..24	-	-	3RF29 20-0GA36
Type current = 30 A			
3RF21 3-1..02	3RF29 00-0EA18	3RF29 20-0FA08	3RF29 50-0GA13
3RF21 3-1..04	3RF29 00-0EA18	3RF29 20-0FA08	3RF29 50-0GA16
3RF21 3-1..06	3RF29 00-0EA18	3RF29 20-0FA08	3RF29 50-0GA16
3RF21 3-1..22	-	-	3RF29 50-0GA33
3RF21 3-1..24	-	-	3RF29 50-0GA36
3RF21 3-1..26	-	-	3RF29 50-0GA36
Type current = 50 A			
3RF21 5-1..02	3RF29 00-0EA18	3RF29 20-0FA08	3RF29 50-0GA13
3RF21 5-1..04	3RF29 00-0EA18	3RF29 20-0FA08	3RF29 50-0GA16
3RF21 5-1..06	3RF29 00-0EA18	3RF29 20-0FA08	3RF29 50-0GA16
3RF21 5-1..22	-	-	3RF29 50-0GA33
3RF21 5-1..24	-	-	3RF29 50-0GA36
3RF21 5-1..26	-	-	3RF29 50-0GA36
3RF21 5-2..02	3RF29 00-0EA18	-	-
3RF21 5-2..04	3RF29 00-0EA18	-	-
3RF21 5-2..06	3RF29 00-0EA18	-	-
3RF21 5-3..02	3RF29 00-0EA18	-	3RF29 50-0GA13
3RF21 5-3..06	3RF29 00-0EA18	-	3RF29 50-0GA16
3RF21 5-3..04	3RF29 00-0EA18	-	3RF29 50-0GA16
3RF21 5-3..22	-	-	3RF29 50-0GA33
3RF21 5-3..24	-	-	3RF29 50-0GA36
3RF21 5-3..26	-	-	3RF29 50-0GA36
Type current = 70 A			
3RF21 7-1..02	3RF29 00-0EA18	3RF29 20-0FA08	3RF29 90-0GA13
3RF21 7-1..04	3RF29 00-0EA18	3RF29 20-0FA08	3RF29 90-0GA16
3RF21 7-1..06	3RF29 00-0EA18	3RF29 20-0FA08	3RF29 90-0GA16
3RF21 7-1..22	-	-	3RF29 90-0GA33
3RF21 7-1..24	-	-	3RF29 90-0GA36
3RF21 7-1..26	-	-	3RF29 90-0GA36
Type current = 90 A			
3RF21 9-1..02	3RF29 00-0EA18	3RF29 20-0FA08	3RF29 90-0GA13
3RF21 9-1..04	3RF29 00-0EA18	3RF29 20-0FA08	3RF29 90-0GA16
3RF21 9-1..06	3RF29 00-0EA18	3RF29 20-0FA08	3RF29 90-0GA16
3RF21 9-1..22	-	-	3RF29 90-0GA33
3RF21 9-1..24	-	-	3RF29 90-0GA36
3RF21 9-1..26	-	-	3RF29 90-0GA36
3RF21 9-2..02	3RF29 00-0EA18	-	-
3RF21 9-2..06	3RF29 00-0EA18	-	-
3RF21 9-2..04	3RF29 00-0EA18	-	-
3RF21 9-3..02	3RF29 00-0EA18	-	3RF29 90-0GA13
3RF21 9-3..04	3RF29 00-0EA18	-	3RF29 90-0GA16
3RF21 9-3..06	3RF29 00-0EA18	-	3RF29 90-0GA16
3RF21 9-3..22	-	-	3RF29 90-0GA33
3RF21 9-3..26	-	-	3RF29 90-0GA36
3RF21 9-3..24	-	-	3RF29 90-0GA36

SIRIUS SC Semiconductor Switching Devices

Semiconductor Relays

22.5 mm semiconductor relays

Fused design with semiconductor protection (similar to type of coordination "2")¹⁾

The semiconductor protection for the SIRIUS SC controlgear can be implemented with different protective devices. This allows protection by means of LV HRC fuses of operational class gL/gG or miniature circuit-breakers. Siemens recommends the use of special SITOR semiconductor fuses. The table below lists the maximum permissible fuses for each SIRIUS SC controlgear.

If a fuse is used with a higher rated current than specified, semiconductor protection is no longer guaranteed. However, smaller fuses with a lower rated current for the load can be used without problems. For protective devices with operational class gL/gG and for 3NE1 SITOR full range fuses, the minimum cross-sections for the conductors to be protected must be taken into account.

Order No.	All-range fuse LV design gR/SITOR 3NE1	Semiconductor protection fuse Cylindrical design			Cable and line protection fuse				DIAZED quick 5SB
		10 × 38 mm aR/SITOR 3NC1 0	14 × 51 mm aR/SITOR 3NC1 4	22 × 58 mm aR/SITOR 3NC2 2	LV design gL/gG/3NA	Cylindrical design			
					10 × 38 mm gL/gG/3NW	14 × 51 mm gL/gG/3NW	22 × 58 mm gL/gG/3NW		
3RF21 2-.....2	3NE1 814-0	3NC1 020	3NC1 420	3NC2 220	3NA2 803	3NW6 001-1	3NW6 101-1	-	5SB1 71
3RF21 2-.....4	3NE1 813-0	3NC1 016	3NC1 420	3NC2 220	3NA2 801	-	3NW6 101-1	-	5SB1 41
3RF21 3-.....2	3NE1 815-0	3NC1 032	3NC1 432	3NC2 232	3NA2 803	-	3NW6 103-1	-	5SB3 11
3RF21 3-.....4	3NE1 815-0	3NC1 025	3NC1 432	3NC2 232	3NA2 803	-	3NW6 101-1	-	5SB1 71
3RF21 3-.....6	3NE1 815-0	3NC1 032	3NC1 432	3NC2 232	3NA2 803-6	-	-	-	-
3RF21 5-.....2	3NE1 817-0	-	3NC1 450	3NC2 250	3NA2 810	-	3NW6 107-1	3NW6 207-1	5SB3 21
3RF21 5-.....4	3NE1 802-0	-	3NC1 450	3NC2 250	3NA2 807	-	-	3NW6 205-1	5SB3 11
3RF21 5-.....6	3NE1 803-0	-	3NC1 450	3NC2 250	3NA2 807-6	-	-	-	-
3RF21 7-.....2²⁾	3NE1 820-0	-	-	3NC2 280	3NA2 817	-	-	3NW6 217-1	5SB3 31
3RF21 7-.....4²⁾	3NE1 020-2	-	-	3NC2 280	3NA2 812	-	-	3NW6 212-1	5SB3 21
3RF21 7-.....6²⁾	3NE1 020-2	-	-	3NC2 280	3NA2 812-6	-	-	-	-
3RF21 9-.....2²⁾	3NE1 021-2	-	-	3NC2 200	3NA2 817	-	-	3NW6 217-1	5SB3 31
3RF21 9-.....4²⁾	3NE1 021-2	-	-	3NC2 280	3NA2 812	-	-	3NW5 212-1	5SB3 21
3RF21 9-.....6²⁾	3NE1 020-2	-	-	3NC2 280	3NA2 812-6	-	-	-	-

- 1) Type of coordination "2" acc. to EN 60947-4-1:
In the event of a short-circuit, the controlgear in the load feeder must not endanger persons or the installation. They must be suitable for further operation. For fused configurations, the protective device must be replaced.
- 2) These versions can also be protected against short-circuit with miniature circuit-breakers as described on page 3/16.

SIRIUS SC Semiconductor Switching Devices

Semiconductor Relays

22.5 mm semiconductor relays

Selection and ordering data

3



3RF21 20-1AA02



3RF21 20-2AA02



3RF21 20-3AA02

Type current ¹⁾	Maximum achievable power for type current and $U_e =$			DT	Screw connection ²⁾	PS	Weight per PU approx.	DT	Spring-loaded connection ³⁾	PS	Weight per PU approx.	DT	Ring cable connection	PS	Weight per PU approx.	
	115 V	230 V	400 V													
A	kW	kW	kW		Order No.		kg		Order No.		kg		Order No.		kg	
Zero-point switching, rated operational voltage $U_e = 24$ V to 230 V																
20	2.3	4.6	-	A	3RF21 20-1AA□2	1 unit	0.052	B	3RF21 20-2AA□2	1 unit	0.052	B	3RF21 20-3AA□2	1 unit	0.052	
30	3.5	6.9	-	A	3RF21 30-1AA□2	1 unit	0.052	-	-	-	-	-	-	-	-	
50	5.8	11.5	-	A	3RF21 50-1AA□2	1 unit	0.052	B	3RF21 50-2AA□2	1 unit	0.052	B	3RF21 50-3AA□2	1 unit	0.052	
70	8.1	16.1	-	A	3RF21 70-1AA□2	1 unit	0.052	-	-	-	-	-	-	-	-	
88	10.4	20.7	-	A	3RF21 90-1AA□2	1 unit	0.052	B	3RF21 90-2AA□2	1 unit	0.052	B	3RF21 90-3AA□2	1 unit	0.052	
Zero-point switching, rated operational voltage $U_e = 230$ V to 460 V																
20	-	4.6	8	A	3RF21 20-1AA□4	1 unit	0.052	B	3RF21 20-2AA□4	1 unit	0.052	B	3RF21 20-3AA□4	1 unit	0.052	
30	-	6.9	12	A	3RF21 30-1AA□4	1 unit	0.052	-	-	-	-	-	-	-	-	
50	-	11.5	20	A	3RF21 50-1AA□4	1 unit	0.052	B	3RF21 50-2AA□4	1 unit	0.052	B	3RF21 50-3AA□4	1 unit	0.052	
70	-	16.1	28	A	3RF21 70-1AA□4	1 unit	0.052	-	-	-	-	-	-	-	-	
88	-	20.7	36	A	3RF21 90-1AA□4	1 unit	0.052	B	3RF21 90-2AA□4	1 unit	0.052	B	3RF21 90-3AA□4	1 unit	0.052	
Zero-point switching, rated operational voltage $U_e = 400$ V to 600 V																
30	-	-	12	B	3RF21 30-1AA□6	1 unit	0.052	-	-	-	-	-	-	-	-	
50	-	-	20	B	3RF21 50-1AA□6	1 unit	0.052	B	3RF21 50-2AA□6	1 unit	0.052	B	3RF21 50-3AA□6	1 unit	0.052	
70	-	-	28	B	3RF21 70-1AA□6	1 unit	0.052	-	-	-	-	-	-	-	-	
88	-	-	36	B	3RF21 90-1AA□6	1 unit	0.052	B	3RF21 90-2AA□6	1 unit	0.052	B	3RF21 90-3AA□6	1 unit	0.052	

Order No. extension for rated control supply voltage U_c

DC 24 V acc. to EN 61131-2
AC 110 V ... 230 V

0
2

0
2

0
2

Other rated control supply voltages on request.

- The type current provides information about the performance of the semiconductor relay. The actual permitted operational current I_e can be smaller depending on the connection method and cooling conditions.
- Please note that this version can only be used for a rated current of up to 50 A and a conductor cross-section of 10 mm².

- Please note that this version can only be used for a rated current of up to 20 A and a conductor cross-section of 2.5 mm².

Version	DT	Order No.	PS	Weight per PU approx.
				kg

Accessories



3RF29 00-3PA88

Screwdriver for spring-loaded connection system

A

8WA2 880

1 unit

0.034

Terminal cover for 3RF21 semiconductor relays and 3RF23 semiconductor contactors with ring terminal end (after simple adaptation, this terminal cover can also be used for screw connection).

A

3RF29 00-3PA88

10 units

0.010

SIRIUS SC Semiconductor Switching Devices

Semiconductor Relays

45 mm semiconductor relays

3

Overview

45 mm semiconductor relays

The semiconductor relays with a width of 45 mm provide for connection of the power supply lead and the load from above. This makes it easy to replace existing semiconductor relays in existing arrangements. The connection of the control cable also saves space in much the same way as the 22.5 mm design, as it is simply plugged on.

Technical specifications

Type	3RF20		
General data			
Ambient temperature			
during operation, derating at 40 °C	°C	-25 ... +60	
when stored	°C	-55 ... +80	
Site altitude	m	0 ... 1000; derating from 1000	
Shock resistance	g/ms	15/11	
acc. to IEC 60068-2-27			
Vibration resistance	g	2	
acc. to IEC 60068-2-6			
Degree of protection		IP20	
Electromagnetic compatibility (EMC)			
Emitted interference			
• Conducted interference voltage IEC acc. to 60947-4-3		Class A for industrial applications	
• Emitted, high-frequency interference voltage acc. to IEC 60947-4-3		Class A for industrial applications	
Noise immunity			
• Electrostatic discharge acc. to IEC 61000-4-2 (corresponds to degree of severity 3)	kV	Contact discharge 4; air discharge 8; behavior criterion 2	
• Induced RF fields acc. to IEC 61000-4-6	MHz	0,15 ... 80; 140 dB μ V; behavior criterion 1	
• Burst acc. to IEC 61000-4-4	kV	2/5,0 kHz; behavior criterion 1	
• Surge acc. to IEC 61000-4-5	kV	Conductor - ground 2; conductor - conductor 1; behavior criterion 2	
Connection, main contacts, screw connection			
Conductor cross-section			
Solid	mm ²	2 × (1,5 ... 2,5); 2 × (2,5 ... 6)	
Finely stranded with end sleeve	mm ²	2 × (1,5 ... 2,5); 2 × (2,5 ... 6); 1 × 10	
Solid or stranded AWG conductors	AWG	2 × (14 ... 10)	
Insulation stripping length	mm	10	
Terminal screw		M 4	
• Tightening torque	Nm	2 ... 2,5	
	lb.in	18 ... 22	
Connection, auxiliary/control contacts, screw connection			
Conductor cross-section			
	mm ²	1x (0,5 ... 2,5); 2x (0,5 ... 1,0); AWG 20 ... 12	
Insulation stripping length	mm	7	
Terminal screw		M 3	
• Tightening torque	Nm	0,5 ... 0,6	
	lb.in	4,5 ... 5,3	
Type	3RF20 .0-1AA.2	3RF20 .0-1AA.4	3RF20 .0-1AA.6
Main circuit			
Rated operational voltage U_e	V	24 ... 230	400 ... 600
• Tolerance	%	-15/+10	
• Rated frequency	Hz	50/60	
Rated insulation voltage U_i	V	600	
Blocking voltage	V	800	1200
Rage of voltage rise	V/ μ s	1000	

SIRIUS SC Semiconductor Switching Devices

Semiconductor Relays

45 mm semiconductor relays

3

Order No.	$I_{max}^{1)}$ at $R_{thha}/T_u = 40\text{ °C}$		I_e to IEC 60947-4-3 at $R_{thha}/T_u = 40\text{ °C}$		I_e to UL/CSA at $R_{thha}/T_u = 50\text{ °C}$		Power loss for I_{max}	Minimum load current	Leakage current
	A	K/W	A	K/W	A	K/W			
Main circuit									
3RF20 20-1AA..	20	2.0	20	2.0	20	1.7	28.6	0.5	10
3RF20 30-1AA..	30	1.1	30	1.1	30	0.88	44.2	0.5	10
3RF20 50-1AA..	50	0.68	50	0.68	50	0.53	66	0.5	10
3RF20 70-1AA..	70	0.4	50	0.95	50	0.8	94	0.5	10
3RF20 90-1AA..	88	0.33	50	1.25	50	1.02	118	0.5	10

1) I_{max} provides information about the performance of the semiconductor relay. The actual permitted operational current I_e can be smaller depending on the connection method and cooling conditions.

Order No.	Rated impulse withstand capacity I_{ISM}	I^2t value
Main circuit		
3RF20 20-1AA..	200	200
3RF20 30-1AA.2	300	450
3RF20 30-1AA.4	300	450
3RF20 30-1AA.6	400	800
3RF20 50-1AA..	600	1800
3RF20 70-1AA.2	1200	7200
3RF20 70-1AA.4	1200	7200
3RF20 70-1AA.6	1150	6600
3RF20 90-1AA..	1150	6600

Type		3RF20 .0-1AA0.	3RF20 .0-1AA2.
Control circuit			
Method of operation		DC operation	AC operation
Rated control supply voltage U_s	V	24 acc. to EN 61131-2	110 ... 230
Max. rated control voltage	V	30	253
Rated control current at U_s	mA	15	6
Rated frequency of the control supply voltage	Hz	-	50/60
Response voltage for tripping current	V mA	15 2	90 2
Drop-out voltage	V	5	40
Operating times			
closing time	ms	1 additional max. one half-wave	40 additional max. one half-wave
opening time	ms	1 additional max. one half-wave	40 additional max. one half-wave

SIRIUS SC Semiconductor Switching Devices

Semiconductor Relays

45 mm semiconductor relays

Fused design with semiconductor protection (similar to type of coordination "2")¹⁾

The semiconductor protection for the SIRIUS SC control gear can be used with different protective devices. This allows protection by means of LV HRC fuses of operational class gL/gG or miniature circuit-breakers. Siemens recommends the use of special SITOR semiconductor fuses. The table below lists the maximum permissible fuses for each SIRIUS SC controlgear.

If a fuse is used with a higher rated current than specified, semiconductor protection is no longer guaranteed. However, smaller fuses with a lower rated current for the load can be used without problems. For protective devices with operational class gL/gG and for SITOR full range fuses 3NE1, the minimum cross-sections for the conductor to be connected must be taken into account.

Order No.	All-range fuse LV design gR/SITOR 3NE1	Semiconductor protection fuse Cylindrical design			Cable and line protection fuse				DIAZED quick 5SB
		10 × 38 mm aR/SITOR 3NC1 0	14 × 51 mm aR/SITOR 3NC1 4	22 × 58 mm aR/SITOR 3NC2 2	LV design gL/gG/3NA	Cylindrical design			
					10 × 38 mm gL/gG 3NW	14 × 51 mm gL/gG 3NW	22 × 58 mm gL/gG 3NW		
3RF20 20-1AA.2 3RF20 20-1AA.4	3NE1 814-0 3NE1 813-0	3NC1 020 3NC1 016	3NC1 420 3NC1 420	3NC2 220 3NC2 220	3NA2 803 3NA2 801	3NW6 001-1 -	3NW6 101-1 3NW6 101-1	- -	5SB1 71 5SB1 41
3RF20 30-1AA.2 3RF20 30-1AA.4 3RF20 30-1AA.6	3NE1 815-0 3NE1 815-0 3NE1 815-0	3NC1 032 3NC1 025 3NC1 032	3NC1 432 3NC1 432 3NC1 432	3NC2 232 3NC2 232 3NC2 232	3NA2 803 3NA2 803 3NA2 803-6	- - -	3NW6 103-1 3NW6 101-1 -	- - -	5SB3 11 5SB1 71 -
3RF20 50-1AA.2 3RF20 50-1AA.4 3RF20 50-1AA.6	3NE1 817-0 3NE1 802-0 3NE1 803-0	- - -	3NC1 450 3NC1 450 3NC1 450	3NC2 250 3NC2 250 3NC2 250	3NA2 810 3NA2 807 3NA2 807-6	- - -	3NW6 107-1 - -	3NW6 207-1 3NW6 205-1 -	5SB3 21 5SB3 11 -
3RF20 70-1AA.2 ²⁾ 3RF20 70-1AA.4 ²⁾ 3RF20 70-1AA.6 ²⁾	3NE1 820-0 3NE1 020-2 3NE1 020-2	- - -	- - -	3NC2 280 3NC2 280 3NC2 280	3NA2 817 3NA2 812 3NA2 812-6	- - -	- - -	3NW6 217-1 3NW6 212-1 -	5SB3 31 5SB3 21 -
3RF20 90-1AA.2 ²⁾ 3RF20 90-1AA.4 ²⁾ 3RF20 90-1AA.6 ²⁾	3NE1 021-2 3NE1 021-2 3NE1 020-2	- - -	- - -	3NC2 200 3NC2 280 3NC2 280	3NA2 817 3NA2 812 3NA2 812-6	- - -	- - -	3NW6 217-1 3NW6 212-1 -	5SB3 31 5SB3 21 -

1) Type of coordination "2" acc. to EN 60947-4-1:

In the event of a short-circuit, the control gear in the load feeder must not endanger persons or the installation. They must be suitable for further operation. For fused configurations, the protective device must be replaced.

2) These versions can also be protected against short-circuit with miniature circuit-breakers as described on page 3/16.

Selection and ordering data

Type current ¹⁾	Maximum achievable power for type current and $U_e =$			DT	Order No. ²⁾	PS	Weight per PU approx.
	115 V	230 V	400 V				
A	kW	kW	kW				kg
Zero-point switching, rated operational voltage $U_e = 24 \text{ V to } 230 \text{ V}$							
	20	2.3	4.6	-	A	3RF20 20-1AA□2	1 unit 0.062
	30	3.5	6.9	-	A	3RF20 30-1AA□2	1 unit 0.062
	50	5.8	11.5	-	A	3RF20 50-1AA□2	1 unit 0.062
	70	8.1	16.1	-	A	3RF20 70-1AA□2	1 unit 0.062
	88	10.4	20.7	-	A	3RF20 90-1AA□2	1 unit 0.062
Zero-point switching, rated operational voltage $U_e = 230 \text{ V to } 460 \text{ V}$							
	20	-	4.6	8	A	3RF20 20-1AA□4	1 unit 0.062
	30	-	6.9	12	A	3RF20 30-1AA□4	1 unit 0.062
	50	-	11.5	20	A	3RF20 50-1AA□4	1 unit 0.062
	70	-	16.1	28	A	3RF20 70-1AA□4	1 unit 0.062
	88	-	20.7	36	A	3RF20 90-1AA□4	1 unit 0.062
Zero-point switching, rated operational voltage $U_e = 400 \text{ V to } 600 \text{ V}$							
	30	-	-	12	B	3RF20 30-1AA□6	1 unit 0.062
	50	-	-	20	B	3RF20 50-1AA□6	1 unit 0.062
	70	-	-	28	B	3RF20 70-1AA□6	1 unit 0.062
	88	-	-	36	B	3RF20 90-1AA□6	1 unit 0.062

Order No. extension for rated control supply voltage U_s

DC 24 V acc. to EN 61131-2
AC 110 V ... 230 V

0
2

Other rated control supply voltages on request.

1) The type current provides information about the performance of the semiconductor relay. The actual permitted operational current I_o can be smaller depending on the connection method and cooling conditions.

2) Please note that this version can only be used for a rated current of up to 50 A and a conductor cross-section of 10 mm².

SIRIUS SC Semiconductor Switching Devices

Semiconductor Contactors

SIRIUS SC semiconductor contactors

Overview

The complete self-contained units consist of a semiconductor relay plus optimized heat sink, and are therefore ready to use. They offer defined rated currents to make selection as easy as possible. Depending on the version, current intensities of up to 88 A are achieved. Like all of our semiconductor switching devices, one of their particular advantages is their compact and space-saving design. With their insulated mounting foot they can easily be snapped onto a standard mounting rail, or they can be mounted on carrier plates with fixing screws. This insulation enables them to be used in circuits with protective extra-low voltage (PELV) or safety extra-low voltage (SELV) in building engineering. For other applications, such as for extended personal safety, the heat sink can be grounded through a screw connection.

Version for resistive loads, "zero-point switching"

This standard version is often used for switching space heaters on and off.

Version for inductive loads, "instantaneous switching"

In this version the semiconductor contactor is specifically matched to inductive loads. Whether it is a matter of frequent actuation of the valves in a filling plant or starting and stopping small drives in packet distribution systems, operation is carried out safely and noiselessly.

Special "low noise" version

Thanks to a special control circuit, this special design can be used in public networks up to 16 A without any additional measures such as interference suppressor filters. As a result it conforms to limit value curve class B in accordance with EN 60947-4-3 in terms of emitted interference.

Special "short-circuit" version

Skilful matching of the power semiconductor with the performance of the semiconductor contactor means that "short-circuit strength" can be achieved with a standard miniature circuit-breaker. In combination with a B-type MCB or a conventional fuse, the result is a short-circuit resistant feeder.

In order to achieve problem-free short-circuit protection by means of miniature circuit-breakers, however, certain boundary conditions must be observed. As the magnitude and duration of the short-circuit current are determined not only by the short-circuit breaking response of the miniature circuit-breaker but also the properties of the wiring system, such as the internal

resistance of the input to the network and damping by switching devices and cables, particular attention must also be paid to these parameters. The necessary cable lengths are therefore shown for the main factor, the conductor resistance, in the table below.

The following miniature circuit-breakers with a B characteristic and 10 kA breaking capacity protect the 3RF2320-.DA.. semiconductor contactors in the event of short-circuits on the load and the specified conductor cross-sections and lengths:

Rated current of miniature circuit-breakers	Example of type	Max. conductor cross-section	Min. cable length from contactor to load
6 A	5SY4 106-6	1 mm ²	5 m
10 A	5SY4 110-6	1.5 mm ²	8 m
16 A	5SY4 116-6	1.5 mm ²	12 m
16 A	5SY4 116-6	2.5 mm ²	20 m
20 A	5SY4 120-6	2.5 mm ²	20 m

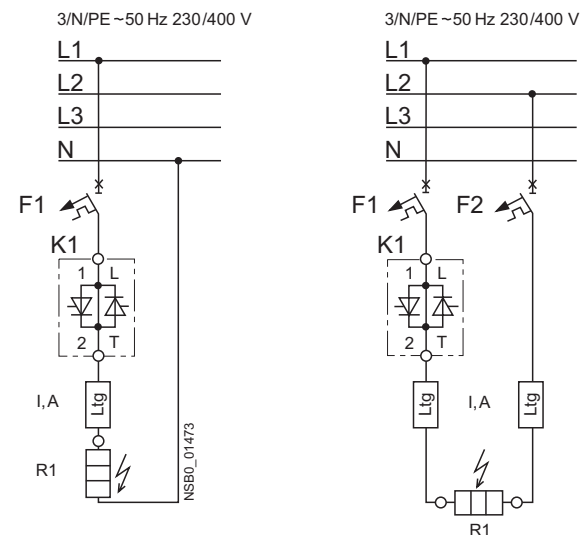

The setup and installation above can also be used for the semiconductor relays with a I^2t value of at least 6600 A²s.

Technical specifications

Order No.	3RF23 ...A...	3RF23 ...B...	3RF23 ...C...	3RF23 ...D...			
General data							
Ambient temperature							
during operation, derating at 40 °C	°C	-25 ... +60					
when stored	°C	-55 ... +80					
Site altitude	m	0 ... 1000; derating from 1000					
Shock resistance acc. to IEC 60068-2-27	g/ms	15/11					
Vibration resistance acc. to IEC 60068-2-6	g	2					
Degree of protection	IP20						
Electromagnetic compatibility (EMC)							
Emitted interference acc. to IEC 60947-4-3							
<ul style="list-style-type: none"> Conducted interference voltage Emitted high-frequency interference voltage 							
<table border="1"> <tr> <td>Class A for industrial applications</td> <td>Class A for industrial applications; Class B for residential/business/commercial areas up to 16 A, AC51 Low Noise</td> <td>Class A for industrial applications</td> </tr> </table>					Class A for industrial applications	Class A for industrial applications; Class B for residential/business/commercial areas up to 16 A, AC51 Low Noise	Class A for industrial applications
Class A for industrial applications	Class A for industrial applications; Class B for residential/business/commercial areas up to 16 A, AC51 Low Noise	Class A for industrial applications					
Noise immunity							
<ul style="list-style-type: none"> Electrostatic discharge acc. to IEC 61000-4-2 (corresponds to degree of severity 3) Induced RF fields acc. to IEC 61000-4-6 Burst acc. to IEC 61000-4-4 Surge acc. to IEC 61000-4-5 							
	kV	Contact discharge 4; air discharge 8; behavior criterion 2					
	MHz	0.15 ... 80; 140 dBµV; behavior criterion 1					
	kV	2/5.0 kHz; behavior criterion 1					
	kV	Conductor - ground 2; conductor - conductor 1; behavior criterion 2					

SIRIUS SC Semiconductor Switching Devices Semiconductor Contactors

SIRIUS SC semiconductor contactors

3

Order No.		3RF23 ..-1....	3RF23 ..-2....	3RF23 ..-3....
General data				
Connection technique		Screw connection	Spring-loaded connection	Ring cable connection
Main contact connection				
Conductor cross-section				
Solid	mm ²	2 × (1.5 ... 2.5), 2 × (2.5 ... 6)	2 × (0.5 ... 2.5)	-
Finely stranded with end sleeve	mm ²	2 × (1.5 ... 2.5), 2 × (2.5 ... 6), 1 × 10	2 × (0.5 ... 1.5)	-
Finely stranded without end sleeves	mm ²		2 × (0.5 ... 2.5)	-
Solid or stranded AWG conductors	AWG	2 × (14 ... 10)	2 × (18 ... 14)	-
Insulation stripping length	mm	10	10	-
Terminal screw		M 4	-	M 5
• Tightening torque	Nm	2 ... 2.5	-	2 ... 2.5
• Tightening torque	lb.in	18 ... 22	-	18 ... 22
Cable lug		-	-	DIN 46234
• DIN		-	-	-5-2.5, -5-6, -5-10, -5-16, -5-25
• JIS		-	-	JIS C 2805 R 2-5, 5.5-5, 8-5, 14-5
Auxiliary/control contact connections				
Conductor cross-section	mm ²	1x (0.5 ... 2.5); 2x (0.5 ... 1.0)	0.5 ... 1.5	1x (0.5 ... 2.5); 2x (0.5 ... 1.0)
	AWG	20 ... 12	20 ... 12	20 ... 12
Insulation stripping length	mm	7	10	7
Terminal screw		M 3	-	M 3
• Tightening torque	Nm	0.5 ... 0.6	-	0.5 ... 0.6
	lb.in	4.5 ... 5.3	-	4.5 ... 5.3

Type		3RF23 ..-...2	3RF23 ..-...4	3RF23 ..-...6
Main circuit				
Rated operational voltage U_e	V	24 ... 230	230 ... 460	400 ... 600
• Tolerance	%	-15/+10		
• Rated frequency	Hz	50/60 Hz		
Rated insulation voltage U_i	V	600		
Blocking voltage	V	800	1200	1600
Rate of voltage rise	V/ μ s	1000		

Order No.	Type current AC-51 ¹⁾			Power loss at I_{max}	Minimum load current	Leakage current	Rated impulse withstand capacity I_{tsm}	I^2t value
	I_{max} at 40 °C	acc. to IEC 60947-4-3 at 40 °C	UL/CSA at 50 °C					
	A	A	A	W	A	mA	A	A ² s
Main circuit								
3RF23 1.-.A..2	10.5	7.5	9.6	11	0.5	10	200	200
3RF23 1.-.A..4							200	200
3RF23 1.-.A..6							400	800
3RF23 2.-.A..2	20	13.2	17.6	20	0.5	10	600	1800
3RF23 2.-.C..2							600	1800
3RF23 2.-.D..2							1150	6600
3RF23 2.-.A..4							10	1800
3RF23 2.-.C..4							25	600
3RF23 2.-.D..4							10	1150
3RF23 2.-.A..6	10	600	1800					
3RF23 3.-.A..2	30	22	27	33	0.5	10	600	1800
3RF23 3.-.A..4								
3RF23 3.-.A..6								
3RF23 4.-.A..2	40	33	36	44	0.5	10	1200	7200
3RF23 4.-.A..4							1200	7200
3RF23 4.-.A..6							1150	6600
3RF23 5.-.A..2	50	36	45	54	0.5	10	1150	6600
3RF23 5.-.A..4								
3RF23 5.-.A..6								
3RF23 7.-.A..2	70	70	62	83	0.5	10	1150	6600
3RF23 7.-.A..4								
3RF23 7.-.A..6								
3RF23 9.-.A..2	88	88	80	117	0.5	10	1150	6600
3RF23 9.-.A..4								
3RF23 9.-.A..6								

1) The type current provides information about the performance of the semiconductor contactor. The actual permitted operational current I_o can be smaller depending on the connection method and start-up conditions. Derating acc. to curves from page 3/30!

SIRIUS SC Semiconductor Switching Devices

Semiconductor Contactors

SIRIUS SC semiconductor contactors

3

Order No.	Type current AC-51 ¹⁾		UL/CSA at 50 °C	AC-15 Parameters		Power loss at I_{max}	Minimum load current	Leakage current	Rated impulse withstand capacity I_{tsm}	I^2t value
	I_{max} at 40 °C	acc. to IEC 60947- 4-3 at 40 °C		A	A					
Main circuit										
3RF23 1.-.B..2 3RF23 1.-.B..4 3RF23 1.-.B..6	10.5	7.5	9.6	6	1200 1/h 50 % ED	11	0.5	10	200 200 400	200 200 800
3RF23 2.-.B..2 3RF23 2.-.B..4 3RF23 2.-.B..6	20	13.2	17.6	12	1200 1/h 50 % ED	20	0.5	10	600	1800
3RF23 3.-.B..2 3RF23 3.-.B..4 3RF23 3.-.B..6	30	22	27	15	1200 1/h 50 % ED	33	0.5	10	600	1800
3RF23 4.-.B..2 3RF23 4.-.B..4 3RF23 4.-.B..6	40	33	36	20	1200 1/h 50 % ED	44	0.5	10	1200 1200 1150	7200 7200 6600
3RF23 5.-.B..2 3RF23 5.-.B..4 3RF23 5.-.B..6	50	36	45	25	1200 1/h 50 % ED	54	0.5	10	1150	6600
3RF23 7.-.B..2 3RF23 7.-.B..4 3RF23 7.-.B..6	70	70	62	27.5	1200 1/h 50 % ED	83	0.5	10	1150	6600
3RF23 9.-.B..2 3RF23 9.-.B..4 3RF23 9.-.B..6	88	88	80	30	1200 1/h 50 % ED	117	0.5	10	1150	6600

1) The type current provides information about the performance of the semiconductor contactor. The actual permitted operational current I_o can be smaller depending on the connection method and start-up conditions. Derating acc. to curves from page 3/30!

Type		3RF23 ...0.	3RF23 ...2.
Control circuit			
Method of operation		DC operation	AC operation
Rated control supply voltage U_s	V	24 to EN 61131-2	110 ... 230
Max. rated control voltage	V	30	253
Rated control current at U_s	mA	15	6
Rated frequency of the control supply voltage	Hz		50/60
Response voltage for tripping current	V mA	15 2	90 2
Drop-out voltage	V	5	40
Operating times			
closing time	ms	1 additional max. one half-wave	40 additional max. one half-wave
opening time	ms	1 additional max. one half-wave	40 additional max. one half-wave

SIRIUS SC Semiconductor Switching Devices Semiconductor Contactors

SIRIUS SC semiconductor contactors

3

Order No.	Accessories			
	Converters	Load monitors		Power controllers
		Basic	Extended	
Type current = 10.5 A				
3RF23 1.-1A.02	3RF29 00-0EA18	3RF29 20-0FA08	3RF29 20-0GA13	-
3RF23 1.-1A.04	3RF29 00-0EA18	3RF29 20-0FA08	3RF29 20-0GA16	-
3RF23 1.-1A.06	3RF29 00-0EA18	3RF29 20-0FA08	3RF29 20-0GA16	-
3RF23 1.-1A.22	-	-	3RF29 20-0GA33	-
3RF23 1.-1A.24	-	-	3RF29 20-0GA36	-
3RF23 1.-1A.26	-	-	3RF29 20-0GA36	-
3RF23 1.-1B.02	3RF29 00-0EA18	3RF29 20-0FA08	3RF29 20-0GA13	3RF29 20-0HA13
3RF23 1.-1B.04	3RF29 00-0EA18	3RF29 20-0FA08	3RF29 20-0GA16	3RF29 20-0HA16
3RF23 1.-1B.06	3RF29 00-0EA18	3RF29 20-0FA08	3RF29 20-0GA16	3RF29 20-0HA16
3RF23 1.-1B.22	-	-	3RF29 20-0GA33	3RF29 20-0HA33
3RF23 1.-1B.24	-	-	3RF29 20-0GA36	3RF29 20-0HA36
3RF23 1.-1B.26	-	-	3RF29 20-0GA36	3RF29 20-0HA36
3RF23 1.-2A.02	3RF29 00-0EA18	-	-	-
3RF23 1.-2A.04	3RF29 00-0EA18	-	-	-
3RF23 1.-2A.06	3RF29 00-0EA18	-	-	-
3RF23 1.-2A.22	-	-	-	-
3RF23 1.-2A.24	-	-	-	-
3RF23 1.-2A.26	-	-	-	-
3RF23 1.-3A.02	3RF29 00-0EA18	-	3RF29 20-0GA13	-
3RF23 1.-3A.04	3RF29 00-0EA18	-	3RF29 20-0GA16	-
3RF23 1.-3A.06	3RF29 00-0EA18	-	3RF29 20-0GA16	-
3RF23 1.-3A.22	-	-	3RF29 20-0GA33	-
3RF23 1.-3A.24	-	-	3RF29 20-0GA36	-
3RF23 1.-3A.26	-	-	3RF29 20-0GA36	-
Type current = 20 A				
3RF23 2.-1A.02	3RF29 00-0EA18	3RF29 20-0FA08	3RF29 20-0GA13	-
3RF23 2.-1A.04	3RF29 00-0EA18	3RF29 20-0FA08	3RF29 20-0GA16	-
3RF23 2.-1A.06	3RF29 00-0EA18	3RF29 20-0FA08	3RF29 20-0GA16	-
3RF23 2.-1A.22	-	-	3RF29 20-0GA33	-
3RF23 2.-1A.24	-	-	3RF29 20-0GA36	-
3RF23 2.-1A.26	-	-	3RF29 20-0GA36	-
3RF23 2.-1B.02	3RF29 00-0EA18	3RF29 20-0FA08	3RF29 20-0GA13	3RF29 20-0HA13
3RF23 2.-1B.04	3RF29 00-0EA18	3RF29 20-0FA08	3RF29 20-0GA16	3RF29 20-0HA16
3RF23 2.-1B.06	3RF29 00-0EA18	3RF29 20-0FA08	3RF29 20-0GA16	3RF29 20-0HA16
3RF23 2.-1B.22	-	-	3RF29 20-0GA33	3RF29 20-0HA33
3RF23 2.-1B.24	-	-	3RF29 20-0GA36	3RF29 20-0HA36
3RF23 2.-1B.26	-	-	3RF29 20-0GA36	3RF29 20-0HA36
3RF23 2.-1C.02	3RF29 00-0EA18	3RF29 20-0FA08	3RF29 20-0GA13	-
3RF23 2.-1C.04	3RF29 00-0EA18	3RF29 20-0FA08	3RF29 20-0GA16	-
3RF23 2.-1C.22	-	-	3RF29 20-0GA33	-
3RF23 2.-1C.24	-	-	3RF29 20-0GA36	-
3RF23 2.-1D.02	3RF29 00-0EA18	3RF29 20-0FA08	3RF29 20-0GA13	-
3RF23 2.-1D.04	3RF29 00-0EA18	3RF29 20-0FA08	3RF29 20-0GA16	-
3RF23 2.-1D.22	-	-	3RF29 20-0GA33	-
3RF23 2.-1D.24	-	-	3RF29 20-0GA36	-
3RF23 2.-2A.02	3RF29 00-0EA18	-	-	-
3RF23 2.-2A.04	3RF29 00-0EA18	-	-	-
3RF23 2.-2A.06	3RF29 00-0EA18	-	-	-
3RF23 2.-2A.22	-	-	-	-
3RF23 2.-2A.24	-	-	-	-
3RF23 2.-2A.26	-	-	-	-
3RF23 2.-2C.02	3RF29 00-0EA18	-	-	-
3RF23 2.-2C.04	3RF29 00-0EA18	-	-	-
3RF23 2.-2C.22	-	-	-	-
3RF23 2.-2C.24	-	-	-	-
3RF23 2.-2D.22	-	-	-	-
3RF23 2.-2D.24	-	-	-	-
3RF23 2.-3A.02	3RF29 00-0EA18	-	3RF29 20-0GA13	-
3RF23 2.-3A.04	3RF29 00-0EA18	-	3RF29 20-0GA16	-
3RF23 2.-3A.06	3RF29 00-0EA18	-	3RF29 20-0GA16	-
3RF23 2.-3A.22	-	-	3RF29 20-0GA33	-
3RF23 2.-3A.24	-	-	3RF29 20-0GA36	-
3RF23 2.-3A.26	-	-	3RF29 20-0GA36	-
3RF23 2.-3D.02	3RF29 00-0EA18	-	3RF29 20-0GA13	-
3RF23 2.-3D.04	3RF29 00-0EA18	-	3RF29 20-0GA16	-
3RF23 2.-3D.22	-	-	3RF29 20-0GA33	-
3RF23 2.-3D.24	-	-	3RF29 20-0GA36	-

SIRIUS SC Semiconductor Switching Devices

Semiconductor Contactors

SIRIUS SC semiconductor contactors

Order No.	Accessories			
	Converters	Load monitors		Power controllers
		Basic	Extended	
Type current = 30 A				
3RF23 3.-1A.02	3RF29 00-0EA18	3RF29 20-0FA08	3RF29 50-0GA13	-
3RF23 3.-1A.04	3RF29 00-0EA18	3RF29 20-0FA08	3RF29 50-0GA16	-
3RF23 3.-1A.06	3RF29 00-0EA18	3RF29 20-0FA08	3RF29 50-0GA16	-
3RF23 3.-1A.22	-	-	3RF29 50-0GA33	-
3RF23 3.-1A.24	-	-	3RF29 50-0GA36	-
3RF23 3.-1A.26	-	-	3RF29 50-0GA36	-
3RF23 3.-1B.02	3RF29 00-0EA18	3RF29 20-0FA08	3RF29 50-0GA13	3RF29 50-0HA13
3RF23 3.-1B.04	3RF29 00-0EA18	3RF29 20-0FA08	3RF29 50-0GA16	3RF29 50-0HA16
3RF23 3.-1B.06	3RF29 00-0EA18	3RF29 20-0FA08	3RF29 50-0GA16	3RF29 50-0HA16
3RF23 3.-1B.22	-	-	3RF29 50-0GA33	3RF29 50-0HA33
3RF23 3.-1B.24	-	-	3RF29 50-0GA36	3RF29 50-0HA36
3RF23 3.-1B.26	-	-	3RF29 50-0GA36	3RF29 50-0HA36
3RF23 3.-3A.02	3RF29 00-0EA18	-	3RF29 50-0GA13	-
3RF23 3.-3A.04	3RF29 00-0EA18	-	3RF29 50-0GA16	-
3RF23 3.-3A.06	3RF29 00-0EA18	-	3RF29 50-0GA16	-
3RF23 3.-3A.22	-	-	3RF29 50-0GA33	-
3RF23 3.-3A.24	-	-	3RF29 50-0GA36	-
3RF23 3.-3A.26	-	-	3RF29 50-0GA36	-
Type current = 40 A				
3RF23 4.-1A.02	3RF29 00-0EA18	-	3RF29 50-0GA13	-
3RF23 4.-1A.04	3RF29 00-0EA18	-	3RF29 50-0GA16	-
3RF23 4.-1A.06	3RF29 00-0EA18	-	3RF29 50-0GA16	-
3RF23 4.-1A.22	-	-	3RF29 50-0GA33	-
3RF23 4.-1A.24	-	-	3RF29 50-0GA36	-
3RF23 4.-1A.26	-	-	3RF29 50-0GA36	-
3RF23 4.-1B.02	3RF29 00-0EA18	-	3RF29 50-0GA13	3RF29 50-0HA13
3RF23 4.-1B.04	3RF29 00-0EA18	-	3RF29 50-0GA16	3RF29 50-0HA16
3RF23 4.-1B.06	3RF29 00-0EA18	-	3RF29 50-0GA16	3RF29 50-0HA16
3RF23 4.-1B.22	-	-	3RF29 50-0GA33	3RF29 50-0HA33
3RF23 4.-1B.24	-	-	3RF29 50-0GA36	3RF29 50-0HA36
3RF23 4.-1B.26	-	-	3RF29 50-0GA36	3RF29 50-0HA36
3RF23 4.-3A.02	3RF29 00-0EA18	-	3RF29 50-0GA13	-
3RF23 4.-3A.04	3RF29 00-0EA18	-	3RF29 50-0GA16	-
3RF23 4.-3A.06	3RF29 00-0EA18	-	3RF29 50-0GA16	-
3RF23 4.-3A.22	-	-	3RF29 50-0GA33	-
3RF23 4.-3A.24	-	-	3RF29 50-0GA36	-
3RF23 4.-3A.26	-	-	3RF29 50-0GA36	-
Type current = 50 A				
3RF23 5.-1A.02	3RF29 00-0EA18	-	3RF29 50-0GA13	-
3RF23 5.-1A.04	3RF29 00-0EA18	-	3RF29 50-0GA16	-
3RF23 5.-1A.06	3RF29 00-0EA18	-	3RF29 50-0GA16	-
3RF23 5.-1A.22	-	-	3RF29 50-0GA33	-
3RF23 5.-1A.24	-	-	3RF29 50-0GA36	-
3RF23 5.-1A.26	-	-	3RF29 50-0GA36	-
3RF23 5.-1B.02	3RF29 00-0EA18	-	3RF29 50-0GA13	3RF29 50-0HA13
3RF23 5.-1B.04	3RF29 00-0EA18	-	3RF29 50-0GA16	3RF29 50-0HA16
3RF23 5.-1B.06	3RF29 00-0EA18	-	3RF29 50-0GA16	3RF29 50-0HA16
3RF23 5.-1B.22	-	-	3RF29 50-0GA33	3RF29 50-0HA33
3RF23 5.-1B.24	-	-	3RF29 50-0GA36	3RF29 50-0HA36
3RF23 5.-1B.26	-	-	3RF29 50-0GA36	3RF29 50-0HA36
3RF23 5.-3A.02	3RF29 00-0EA18	-	3RF29 50-0GA13	-
3RF23 5.-3A.04	3RF29 00-0EA18	-	3RF29 50-0GA16	-
3RF23 5.-3A.06	3RF29 00-0EA18	-	3RF29 50-0GA16	-
3RF23 5.-3A.22	-	-	3RF29 50-0GA33	-
3RF23 5.-3A.24	-	-	3RF29 50-0GA36	-
3RF23 5.-3A.26	-	-	3RF29 50-0GA36	-
Type current = 70 A				
3RF23 7.-1B.02	3RF29 00-0EA18	-	3RF29 90-0GA13	3RF29 90-0HA13
3RF23 7.-1B.04	3RF29 00-0EA18	-	3RF29 90-0GA16	3RF29 90-0HA16
3RF23 7.-1B.06	3RF29 00-0EA18	-	3RF29 90-0GA16	3RF29 90-0HA16
3RF23 7.-1B.22	-	-	3RF29 90-0GA33	3RF29 90-0HA33
3RF23 7.-1B.24	-	-	3RF29 90-0GA36	3RF29 90-0HA36
3RF23 7.-1B.26	-	-	3RF29 90-0GA36	3RF29 90-0HA36
3RF23 7.-3A.02	3RF29 00-0EA18	-	3RF29 90-0GA13	-
3RF23 7.-3A.04	3RF29 00-0EA18	-	3RF29 90-0GA16	-
3RF23 7.-3A.06	3RF29 00-0EA18	-	3RF29 90-0GA16	-
3RF23 7.-3A.22	-	-	3RF29 90-0GA33	-
3RF23 7.-3A.24	-	-	3RF29 90-0GA36	-
3RF23 7.-3A.26	-	-	3RF29 90-0GA36	-

SIRIUS SC Semiconductor Switching Devices Semiconductor Contactors

SIRIUS SC semiconductor contactors

3

Order No.	Accessories			
	Converters	Load monitors		Power controllers
		Basic	Extended	

Type current = 70 A

3RF23 7.-3B.02	3RF29 00-0EA18	-	3RF29 90-0GA13	3RF29 90-0HA13
3RF23 7.-3B.04	3RF29 00-0EA18	-	3RF29 90-0GA16	3RF29 90-0HA16
3RF23 7.-3B.06	3RF29 00-0EA18	-	3RF29 90-0GA16	3RF29 90-0HA16
3RF23 7.-3B.22	-	-	3RF29 90-0GA33	3RF29 90-0HA33
3RF23 7.-3B.24	-	-	3RF29 90-0GA36	3RF29 90-0HA36
3RF23 7.-3B.26	-	-	3RF29 90-0GA36	3RF29 90-0HA36

Type current = 90 A

3RF23 9.-1B.02	3RF29 00-0EA18	-	3RF29 90-0GA13	3RF29 90-0HA13
3RF23 9.-1B.04	3RF29 00-0EA18	-	3RF29 90-0GA16	3RF29 90-0HA16
3RF23 9.-1B.06	3RF29 00-0EA18	-	3RF29 90-0GA16	3RF29 90-0HA16
3RF23 9.-1B.22	-	-	3RF29 90-0GA33	3RF29 90-0HA33
3RF23 9.-1B.24	-	-	3RF29 90-0GA36	3RF29 90-0HA36
3RF23 9.-1B.26	-	-	3RF29 90-0GA36	3RF29 90-0HA36
3RF23 9.-3A.02	3RF29 00-0EA18	-	3RF29 90-0GA13	-
3RF23 9.-3A.04	3RF29 00-0EA18	-	3RF29 90-0GA16	-
3RF23 9.-3A.06	3RF29 00-0EA18	-	3RF29 90-0GA16	-
3RF23 9.-3A.22	-	-	3RF29 90-0GA33	-
3RF23 9.-3A.24	-	-	3RF29 90-0GA36	-
3RF23 9.-3A.26	-	-	3RF29 90-0GA36	-
3RF23 9.-3B.02	3RF29 00-0EA18	-	3RF29 90-0GA13	3RF29 90-0HA13
3RF23 9.-3B.04	3RF29 00-0EA18	-	3RF29 90-0GA16	3RF29 90-0HA16
3RF23 9.-3B.06	3RF29 00-0EA18	-	3RF29 90-0GA16	3RF29 90-0HA16
3RF23 9.-3B.22	-	-	3RF29 90-0GA33	3RF29 90-0HA33
3RF23 9.-3B.24	-	-	3RF29 90-0GA36	3RF29 90-0HA36
3RF23 9.-3B.26	-	-	3RF29 90-0GA36	3RF29 90-0HA36

Fused design with semiconductor protection (similar to type of coordination "2")¹⁾

The semiconductor protection for the SIRIUS SC controlgear can be used with different protective devices. This allows protection by means of LV HRC fuses of operational class gL/gG or miniature circuit-breakers. Siemens recommends the use of special SITOR semiconductor fuses. The table below lists the maximum permissible fuses for each SIRIUS SC control gear.

If a fuse is used with a higher rated current than specified, semiconductor protection is no longer guaranteed. However, smaller fuses with a lower rated current for the load can be used without problems.

For protective devices with operational class gL/gG and for SITOR full range fuses 3NE1, the minimum cross-sections for the conductor to be connected must be taken into account.

Order No.	All-range fuse LV HRC design gR/SITOR 3NE1	Semiconductor protection fuse Cylindrical design			Cable and line protection fuse				DIAZED quick 5SB
		10 x 38 mm aR/SITOR 3NC1 0	14 x 51 mm aR/SITOR 3NC1 4	22 x 58 mm aR/SITOR 3NC2 2	LV HRC design gL/gG 3NA	Cylindrical design			
						10 x 38 mm gL/gG 3NW	14 x 51 mm gL/gG 3NW	22 x 58 mm gL/gG 3NW	
3RF23 1.-....2	3NE1 813-0	3NC1 010	3NC1 410	3NC2 220	3NA2 803	3NW6 001-1	3NW6 101-1	-	5SB1 41
3RF23 1.-....4	3NE1 813-0	3NC1 010	3NC1 410	3NC2 220	3NA2 801	3NW6 001-1	3NW6 101-1	-	5SB1 41
3RF23 1.-....6	3NE1 813-0	3NC1 010	3NC1 410	3NC2 220	3NA2 803-6	-	-	-	-
3RF23 2.-....2	3NE1 814-0	3NC1 020	3NC1 420	3NC2 220	3NA2 807	3NW6 007-1	3NW6 107-1	3NW6 207-1	5SB1 71
3RF23 2.-....4	3NE1 814-0	3NC1 020	3NC1 420	3NC2 220	3NA2 807	3NW6 005-1	3NW6 105-1	3NW6 205-1	5SB1 71
3RF23 2.-....6	3NE1 814-0	3NC1 020	3NC1 420	3NC2 220	3NA2 807-6	-	-	-	-
3RF23 3.-....2	3NE1 803-0	3NC1 032	3NC1 432	3NC2 232	3NA2 810	-	3NW6 107-1	3NW6 207-1	5SB3 11
3RF23 3.-....4	3NE1 803-0	3NC1 032	3NC1 432	3NC2 232	3NA2 807	-	3NW6 105-1	3NW6 205-1	5SB3 11
3RF23 3.-....6	3NE1 803-0	3NC1 032	3NC1 432	3NC2 232	3NA2 807-6	-	-	-	-
3RF23 4.-....2	3NE1 802-0	-	3NC1 440	3NC2 240	3NA2 817	-	3NW6 117-1	3NW6 217-1	5SB3 21
3RF23 4.-....4	3NE1 802-0	-	3NC1 440	3NC2 240	3NA2 812	-	3NW6 112-1	3NW6 212-1	5SB3 21
3RF23 4.-....6	3NE1 802-0	-	3NC1 440	3NC2 240	3NA2 812-6	-	-	-	-
3RF23 5.-....2	3NE1 817-0	-	3NC1 450	3NC2 250	3NA2 817	-	3NW6 117-1	3NW6 217-1	5SB3 21
3RF23 5.-....4	3NE1 817-0	-	3NC1 450	3NC2 250	3NA2 812	-	-	3NW6 210-1	5SB3 21
3RF23 5.-....6	3NE1 817-0	-	3NC1 450	3NC2 250	3NA2 812-6	-	-	-	-
3RF23 7.-....2	3NE1 820-0	-	-	3NC2 280	3NA2 817	-	-	3NW6 217-1	5SB3 31
3RF23 7.-....4	3NE1 020-2	-	-	3NC2 280	3NA2 812	-	-	3NW6 210-1	5SB3 21
3RF23 7.-....6	3NE1 020-2	-	-	3NC2 280	3NA2 812-6	-	-	-	-
3RF23 9.-....2	3NE1 021-2	-	-	3NC2 200	3NA2 817	-	-	3NW6 217-1	5SB3 31
3RF23 9.-....4	3NE1 021-2	-	-	3NC2 280	3NA2 812	-	-	3NW6 210-1	5SB3 21
3RF23 9.-....6	3NE1 020-2	-	-	3NC2 280	3NA2 812-6	-	-	-	-

1) Type of coordination "2" acc. to EN 60947-4-1:

In the event of a short-circuit, the controlgear in the load feeder must not endanger persons or the installation. They must be suitable for further operation. For fused configurations, the protective device must be replaced.

SIRIUS SC Semiconductor Switching Devices

Semiconductor Contactors

SIRIUS SC semiconductor contactors

Further information

Notes on selection

These notes are intended for general orientation and will no doubt be sufficient for most applications. If the installation conditions differ significantly from the examples described here, you can contact our Technical Assistance team for further help.

Telephone: +49 9131 7 43833
Fax: +49 9131 7 42899
e-mail: nst.technical-assistance@siemens.com

For more information on the Internet go to
www.siemens.com/lowvoltage/technical-assistance

Selecting semiconductor contactors

The semiconductor contactors are selected on the basis of details of the power system, the load and the ambient conditions. As the semiconductor contactors are already equipped with an optimally matched heat sink, the selection process is considerably simpler than that for semiconductor relays.

The following procedure is recommended:

- Determine the rated current of the load and the mains voltage
- Select a semiconductor contactor with the same or higher rated current than the load
- Check the correct contactor size with the aid of the rated current diagram, taking account of the design conditions

SIRIUS SC Semiconductor Switching Devices

Function Modules

General data

3

Overview

Function modules for SIRIUS SC semiconductor switching devices

A great variety of applications demand an expanded range of functionality. With our function modules, these requirements can be met really easily. The modules are mounted simply by clicking them into place; straight away the necessary connections are made with the semiconductor relay or contactor.

The plug-in connection to control the semiconductor switching devices can simply remain in use.

The following function modules are available:

- Converters
- Load monitors
- Power controllers

Technical specifications

Type		3RF29 ...-E...	3RF29 ...-F...	3RF29 ...-G...	3RF29 ...-H...
General data					
Ambient temperature					
during operation, derating at 40 °C	°C	-25 ... +60			
when stored	°C	-55 ... +80			
Site altitude	m	0 ... 1000; derating from 1000			
Shock resistance acc. to IEC 60068-2-27	g/ms	15/11			
Vibration resistance acc. to IEC 60068-2-6	g	2			
Degree of protection		IP20			
Electromagnetic compatibility (EMC)					
Emitted interference					
• Conducted interference voltage acc. to IEC 60947-4-3					
• Emitted, high-frequency interference voltage acc. to IEC 60947-4-3					
Class A for industrial applications ¹⁾					
Noise immunity					
• Electrostatic discharge acc. to IEC 61000-4-2 (corresponds to degree of severity 3)					
• Induced RF fields acc. to IEC 61000-4-6					
• Burst acc. to IEC 61000-4-4					
• Surge acc. to IEC 61000-4-5					
Contact discharge 4; air discharge 8; behavior criterion 2					
0.15 ... 80; 140 dBµV; behavior criterion 1					
2 kV/5.0 kHz; behavior criterion 1					
Conductor - ground 2; conductor - conductor 1; behavior criterion 2					
Connection, auxiliary/control contacts, screw connection					
Conductor cross-section	mm ²	1x (0.5 ... 2.5); 2x (0.5 ... 1) AWG 20 ... 12			
• Insulation stripping length	mm	7			
Terminal screw		M3			
• Tightening torque	Nm	0.5 ... 0.6			
Converter diameter of hole	mm	-	7	17	

1) Note limitations for power controller function module on page 3/28.

Type		3RF29 ...-E..8	3RF29 ...-F..8	3RF29 ...-G..3	3RF29 ...-G..6	3RF29 ...-H..3	3RF29 ...-H..6
Main circuit							
Rated operational voltage U_e	V	1 ¹⁾		110 ... 230	400 ... 600	110 ... 230	400 ... 600
• Tolerance	%	-		-15 / +10			
• Rated frequency	Hz	-		50/60			
Rated insulation voltage U_i	V	-		600			
Voltage detection							
Measuring range	V	-		93.5 ... 253	340 ... 660	93.5 ... 253	340 ... 660
Mains voltage fluctuation compensation	%	-		20			

1) Versions do not depend on main circuit.

Type		3RF29 ...-...0.	3RF29 ...-...1.	3RF29 ...-...3.
Control circuit				
Method of operation		DC operation	AC/DC operation	AC operation
Rated control supply voltage U_s	V	24	24	110
Rated operating current	mA	15	15	15
Max. rated control voltage	V	30	30	121
Rated control current at maximum voltage	mA	15	15	15
Rated frequency of the control supply voltage	Hz	-	50/60	50/60
Response voltage for tripping current	V	15	15	90
	mA	2	2	2
Drop-out voltage	V	5	5	-

Type		3RF29 2.-.F...	3RF29 2.-.G...	3RF29 2.-.H...	3RF29 5.-.G...	3RF29 5.-.H...	3RF29 9.-.G...	3RF29 9.-.H...
Current detection								
Rated operational current I_e	A	20			50	90		
Measuring range	A	4 ... 22			4 ... 55	4 ... 99		
Number of partial loads		6	12	-	12	-	12	-

Characteristics

SIRIUS SC semiconductor relays

Dependence of the device current I_e on the ambient temperature T_a

SIRIUS SC semiconductor relay with 20 A type current (3RF21 20/3RF20 20)¹⁾

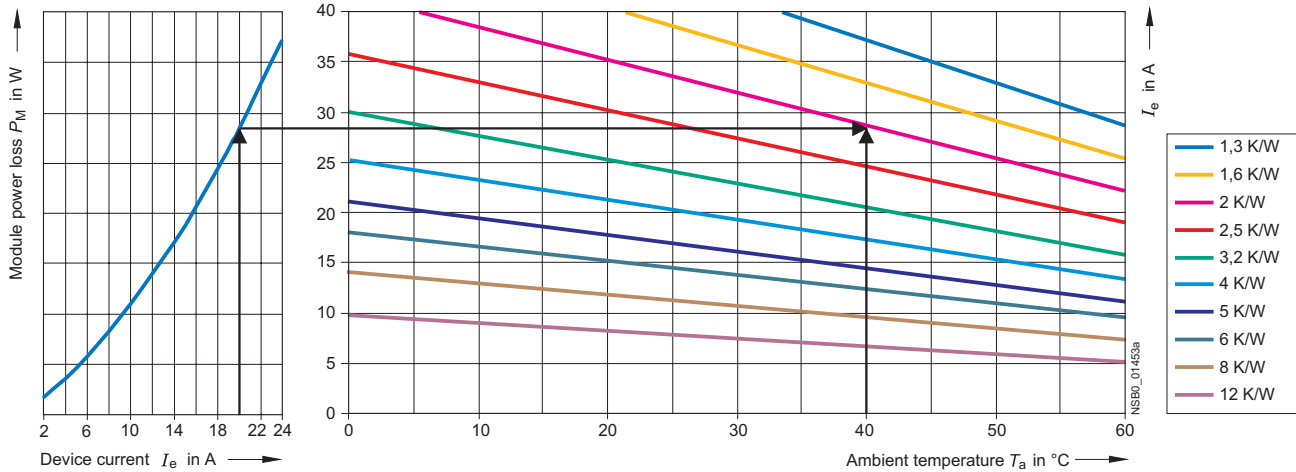

SIRIUS SC semiconductor relay with 30 A type current (3RF21 30/3RF20 30)

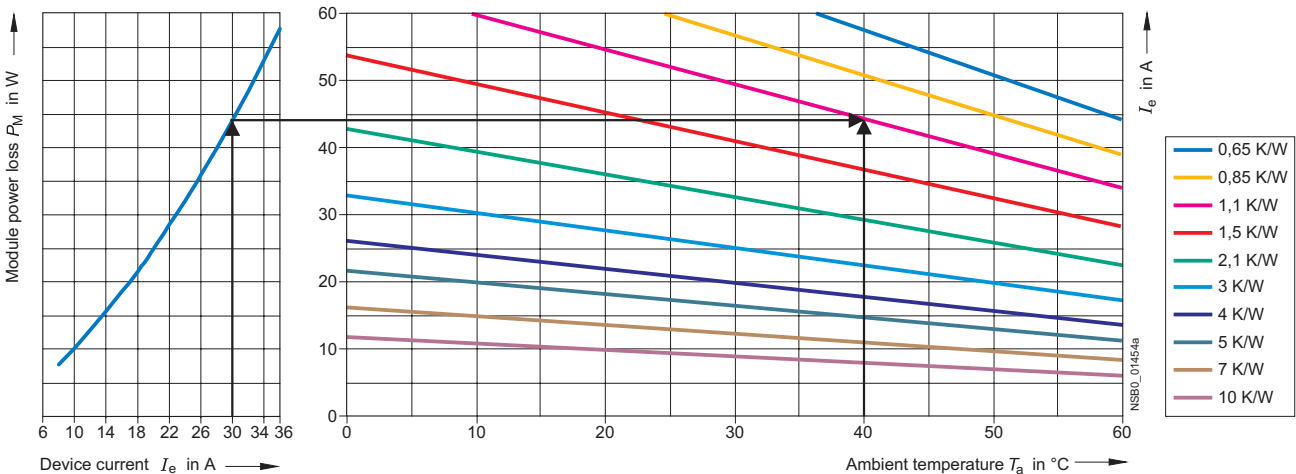

SIRIUS SC semiconductor relay with 50 A type current (3RF21 50/3RF20 50)

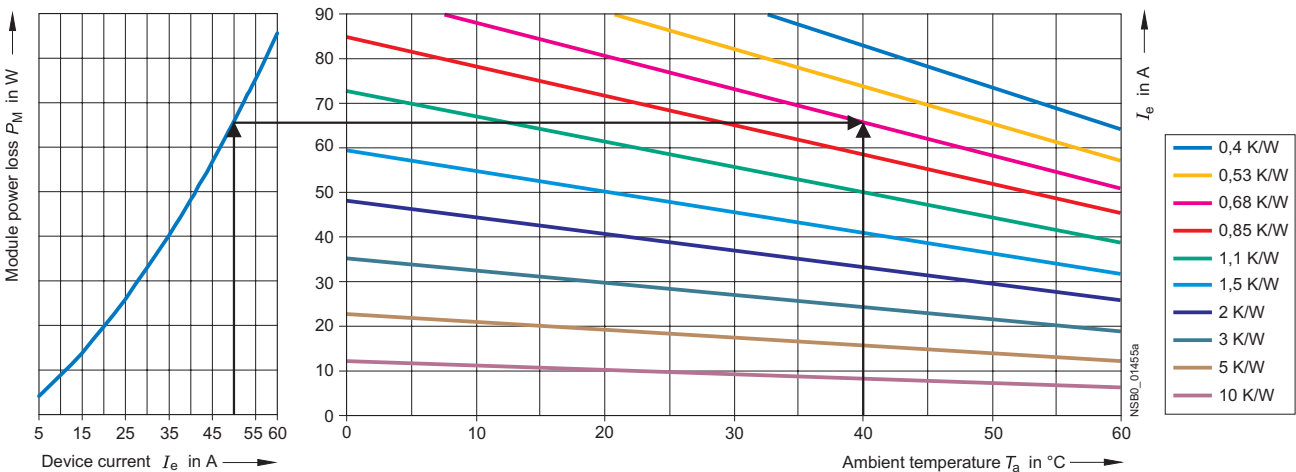

1) Arrangement example for $I_e = 20$ A and $T_a = 40$ °C:
The task is to find the thermal resistance R_{thha} and the heat-sink overtemperature dT_{ha} . From the diagram on the left $\rightarrow P_M = 28$ W, from the diagram on the right $\rightarrow R_{thha} = 1.7$ K/W.

This results in: $dT_{ha} = R_{thha} \times P_M = 1.7 \text{ K/W} \times 28 \text{ W} = 47.6 \text{ K}$. At $dT_{ha} = 47.6 \text{ K}$ the heat sink must therefore have an $R_{thha} = 1.7 \text{ K/W}$.

SIRIUS SC Semiconductor Switching Devices

Semiconductor Relays and Contactors, Function Modules

Project planning aids

Dependence of the device current I_e on the ambient temperature T_a

SIRIUS SC semiconductor relay with 70 A type current (3RF21 70/3RF20 70)

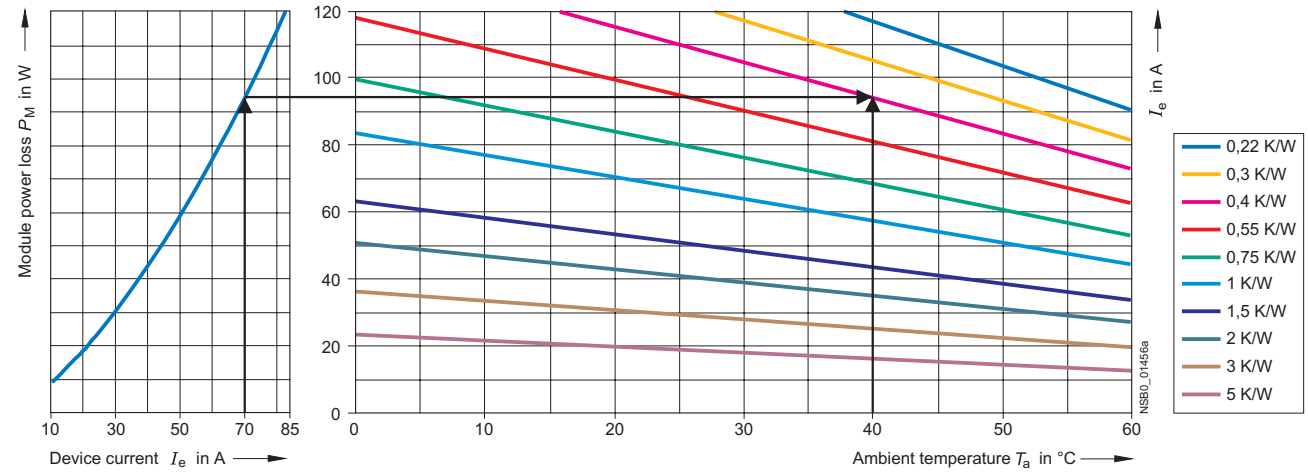

SIRIUS SC semiconductor relay with 88 A type current (3RF21 90/3RF20 90)

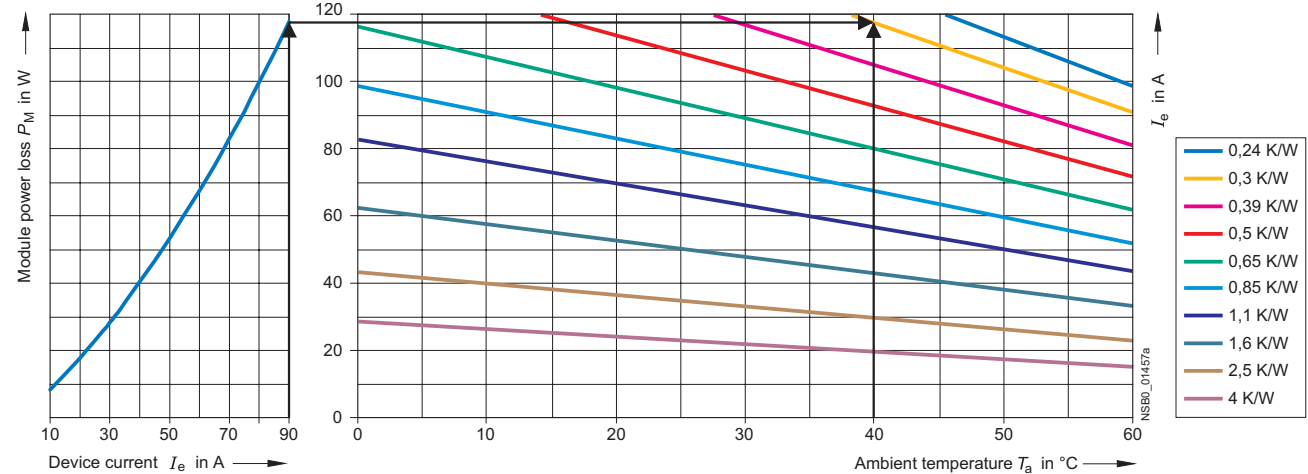

SIRIUS SC semiconductor contactors

Derating curves

SIRIUS SC semiconductor contactor with 10 A type current (3RF23 10)

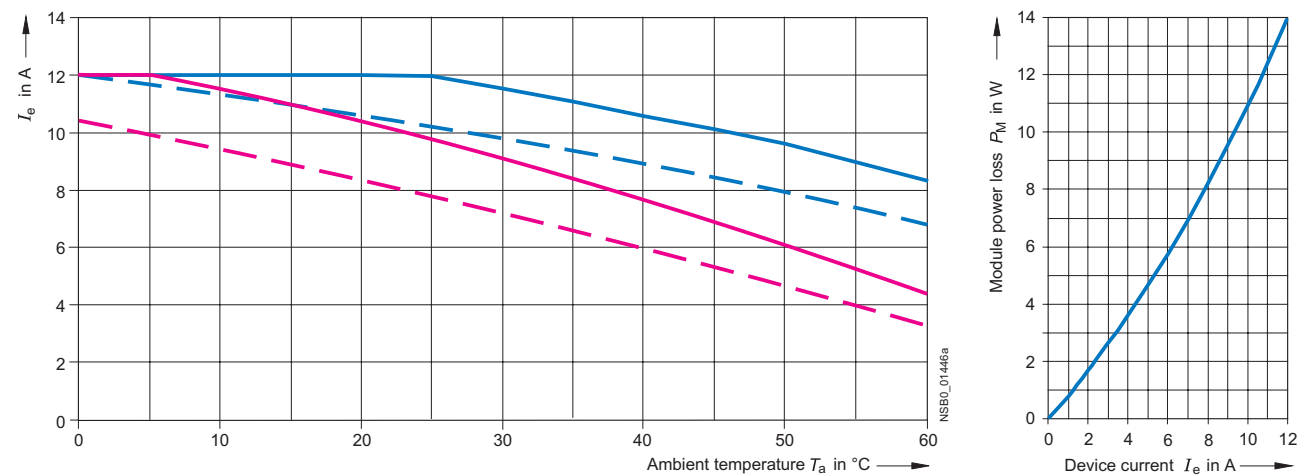

SIRIUS SC Semiconductor Switching Devices

Semiconductor Relays and Contactors, Function Modules

Project planning aids

3

Derating curves

SIRIUS SC semiconductor contactor with 20 A type current (3RF23 20)

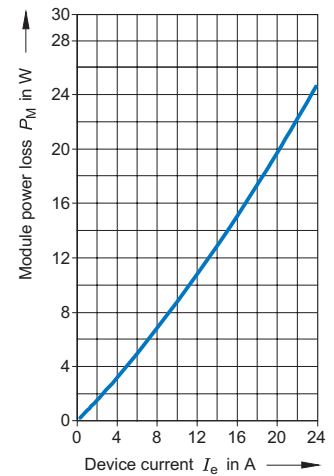
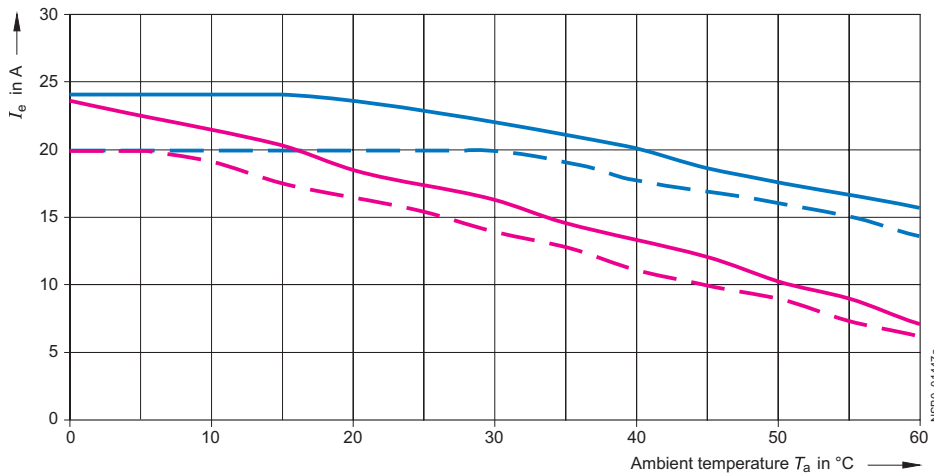

SIRIUS SC semiconductor contactor with 30 A type current (3RF23 30)

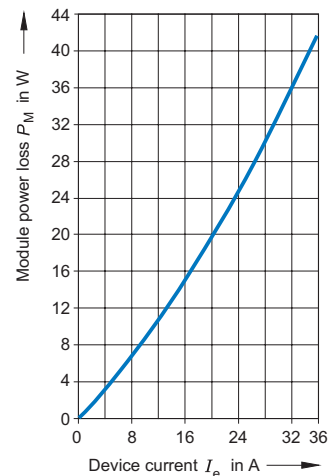
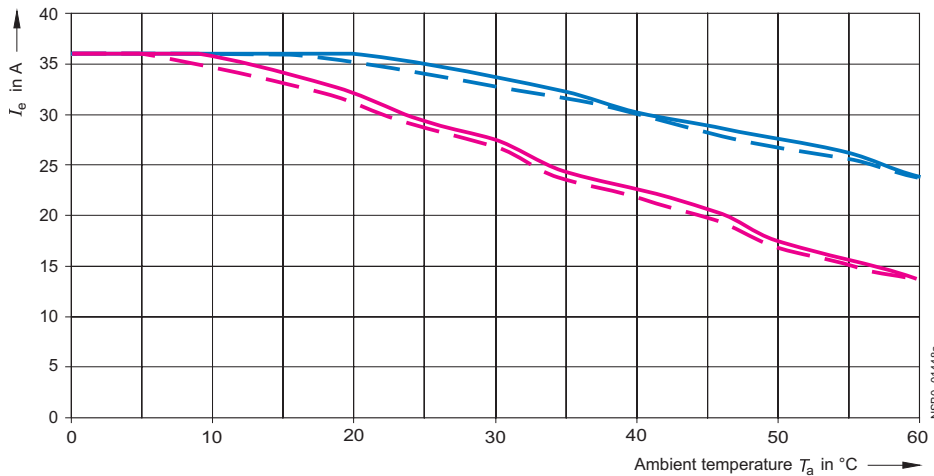

SIRIUS SC semiconductor contactor with 40 A type current (3RF23 40)¹⁾

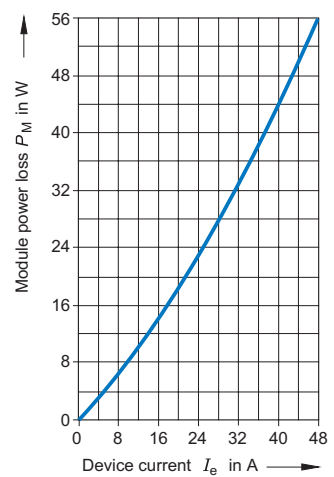
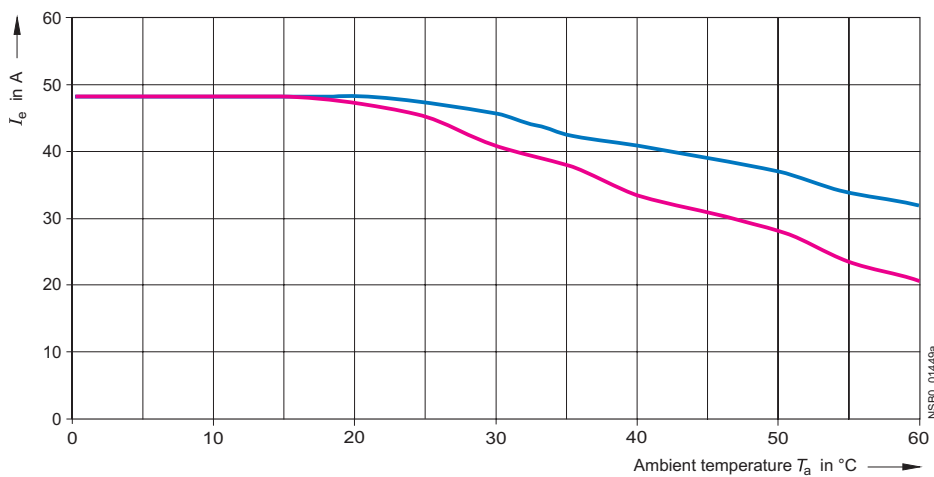

- I_{max} Thermal limit current for individual mounting
- - I_{max} Thermal limit current for side-by-side mounting
- I_{IEC} Current acc. to IEC 947-4-3 for individual mounting
- - I_{IEC} Current acc. to IEC 947-4-3 for side-by-side mounting

NSB0_01474

1) Identical current/temperature curves for individual and side-by-side mounting.

SIRIUS SC Semiconductor Switching Devices

Semiconductor Relays and Contactors, Function Modules

Project planning aids

Derating curves

SIRIUS SC semiconductor contactor with 50 A type current (3RF23 50)¹⁾

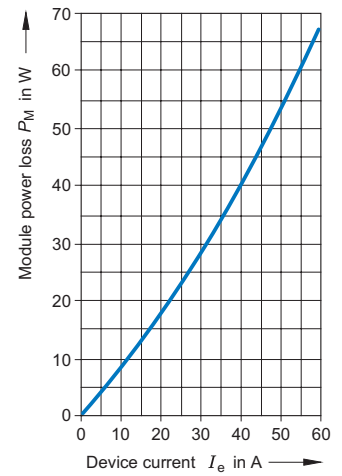
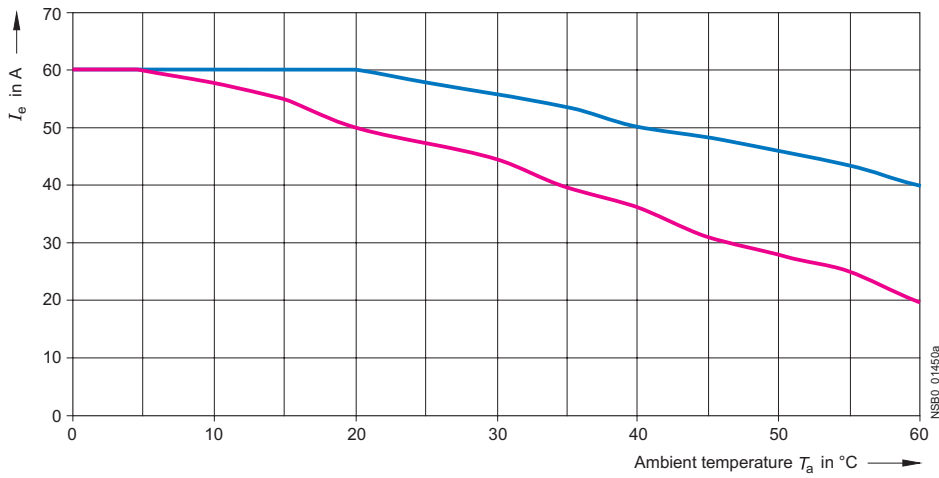

SIRIUS SC semiconductor contactor with 70 A type current (3RF23 70)¹⁾

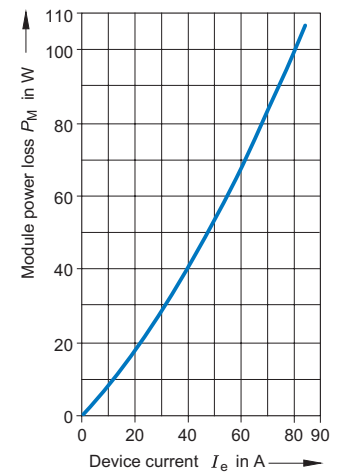
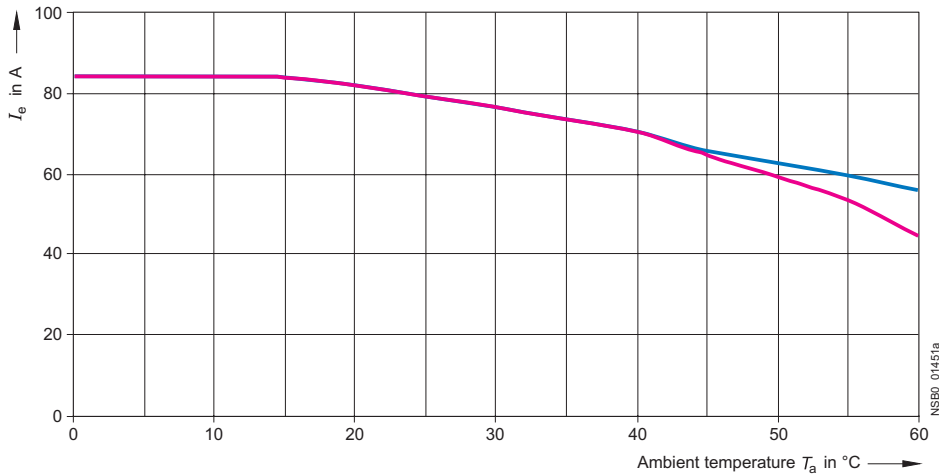

SIRIUS SC semiconductor contactor with 88 A type current (3RF23 90)¹⁾

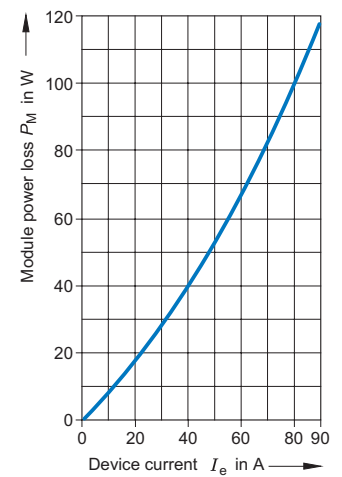
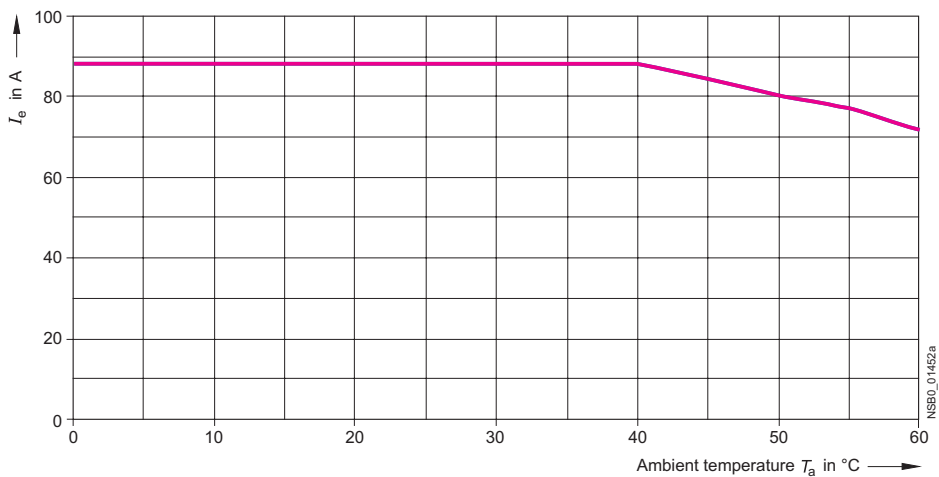

- I_{\max} Thermal limit current for individual mounting
- - I_{\max} Thermal limit current for side-by-side mounting
- I_{IEC} Current acc. to IEC 947-4-3 for individual mounting
- - I_{IEC} Current acc. to IEC 947-4-3 for side-by-side mounting

NSB0_01474

¹⁾ Identical current/temperature curves for individual and side-by-side mounting.

SIRIUS SC Semiconductor Switching Devices

Semiconductor Relays and Contactors, Function Modules

Project planning aids

3

Dimension drawings

SIRIUS SC semiconductor relays

22.5 mm semiconductor relays

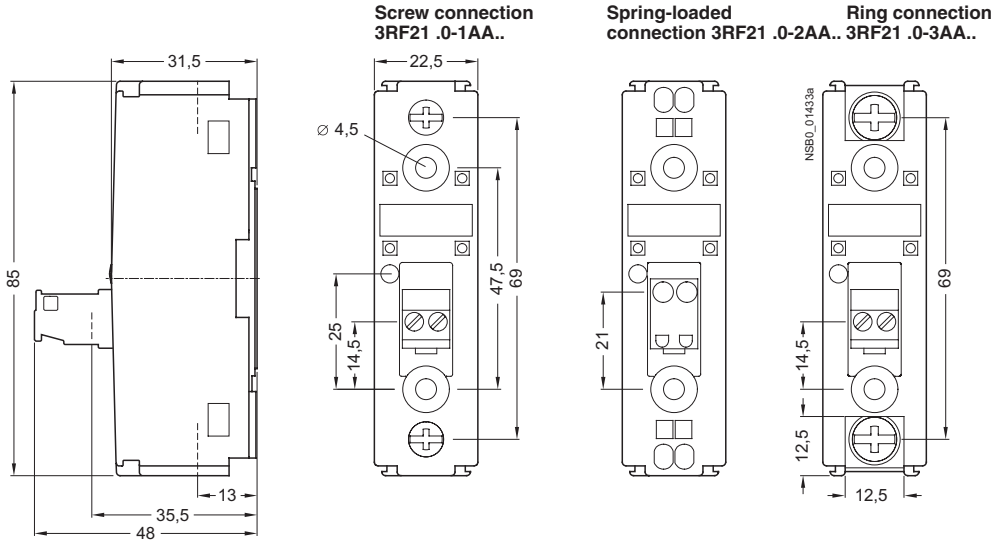

45 mm semiconductor relays

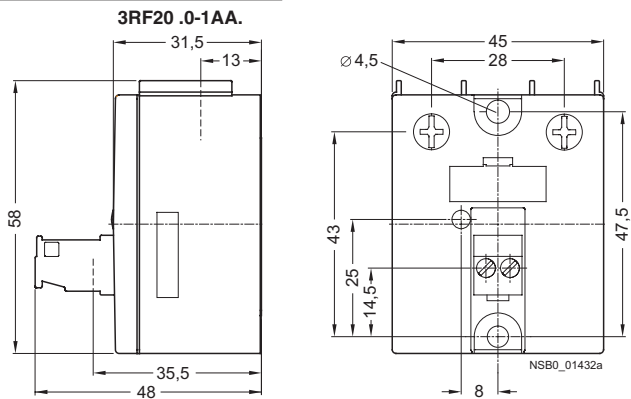

SIRIUS SC Semiconductor Switching Devices

Semiconductor Relays and Contactors, Function Modules

Project planning aids

SIRIUS SC semiconductor contactors

Semiconductor contactors with 10 A and 20 A type current

3RF23 10-....

3RF23 20-....

Screw connection
3RF23 10-1....
3RF23 20-1....

Spring-loaded connection
3RF23 10-2....
3RF23 20-2....

Ring connection
3RF23 10-3....
3RF23 20-3....

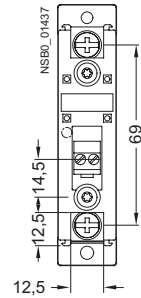
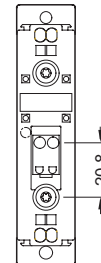
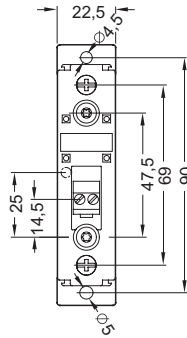
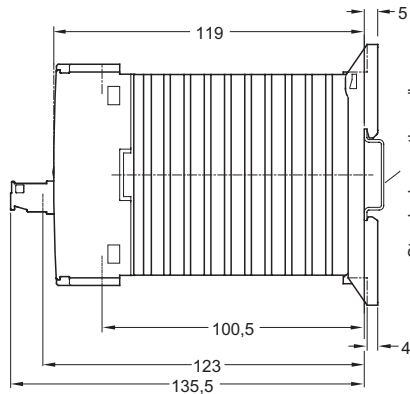
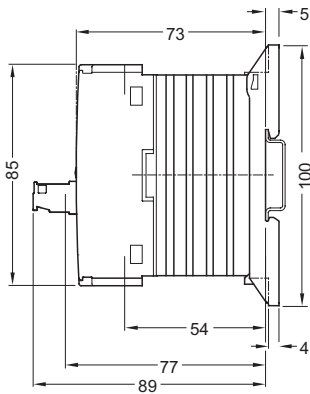

Semiconductor contactors with 30 A type current

Screw connection
3RF23 30-1....

Ring connection
3RF23 30-3....

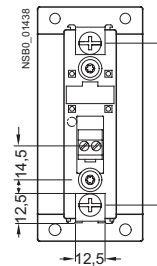
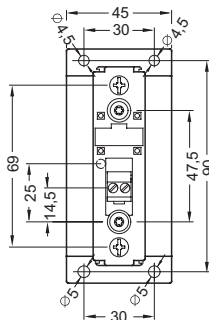
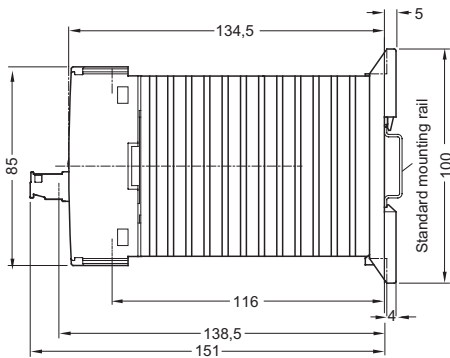

Semiconductor contactors with 40 A and 50 A type current

Screw connection
3RF23 40-1....
3RF23 50-1....

Ring connection
3RF23 40-3....
3RF23 50-3....

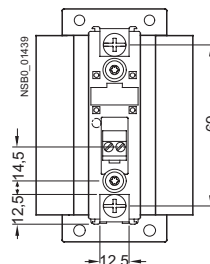
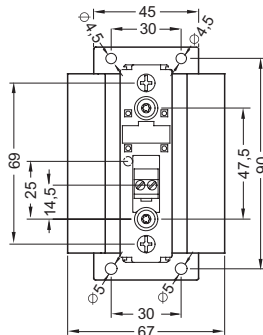
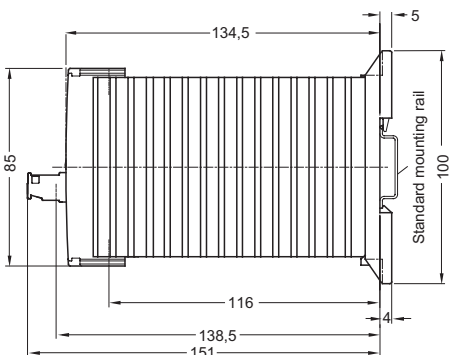

SIRIUS SC Semiconductor Switching Devices

Semiconductor Relays and Contactors, Function Modules

Project planning aids

3

Semiconductor contactors with 70 A type current

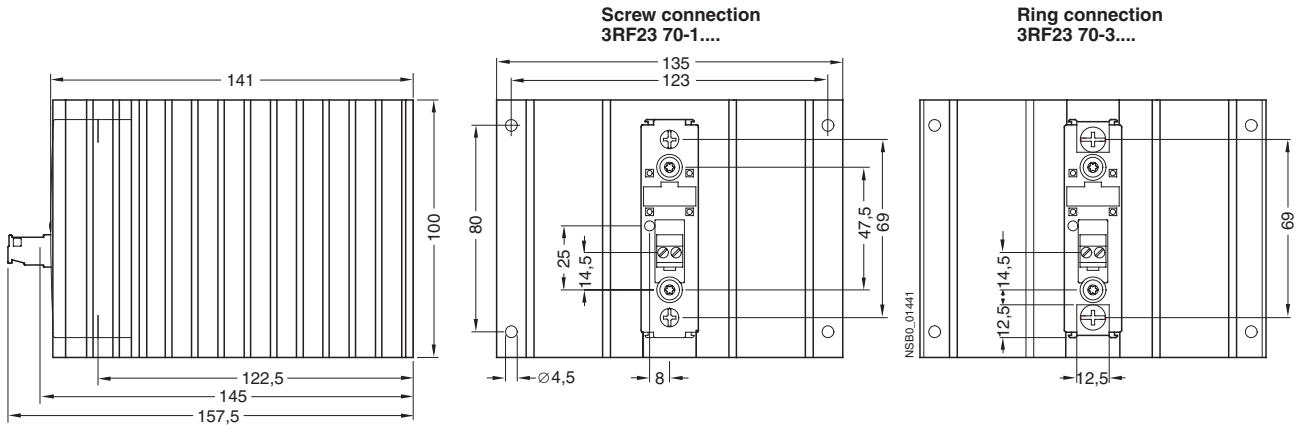

Semiconductor contactors with 88 A type current

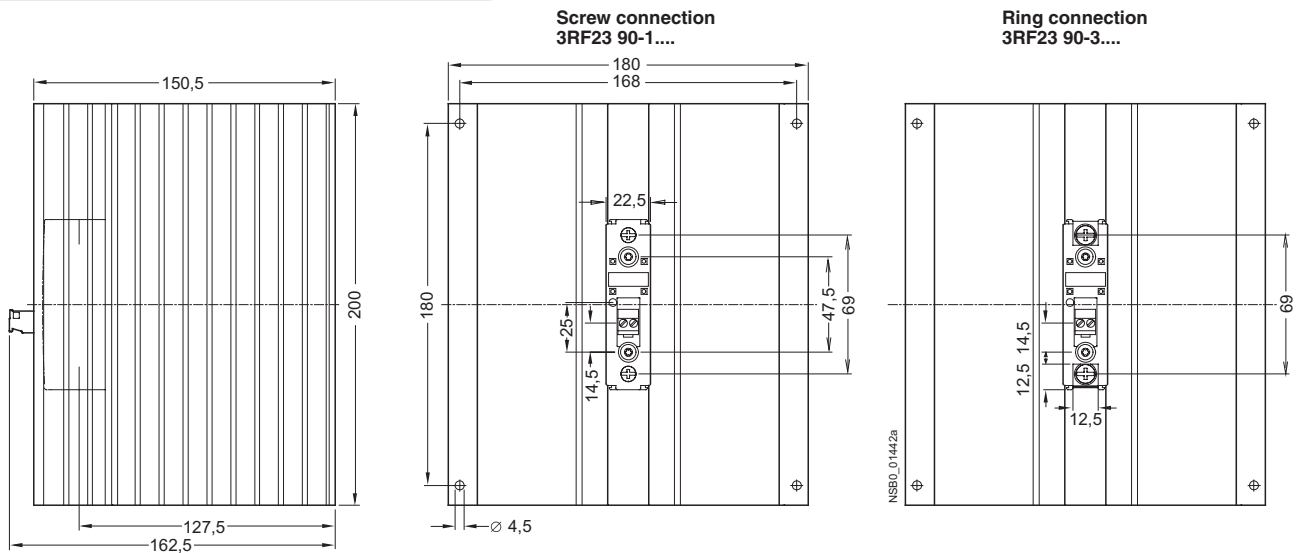

SIRIUS SC Semiconductor Switching Devices

Semiconductor Relays and Contactors, Function Modules

Project planning aids

Function modules for SIRIUS SC semiconductor switching devices

Converters
3RF29 00-0EA18

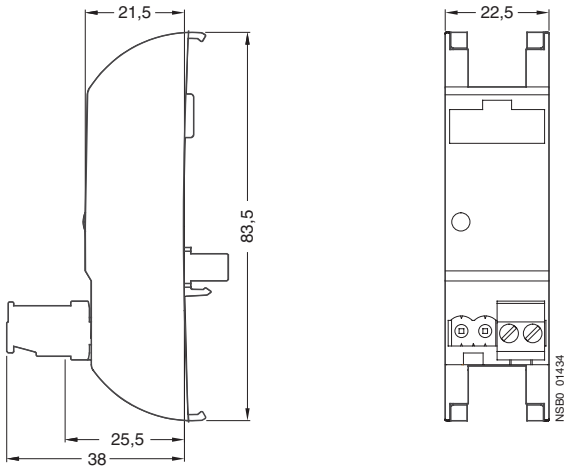

Basic load monitoring
3RF29 00-0FA08

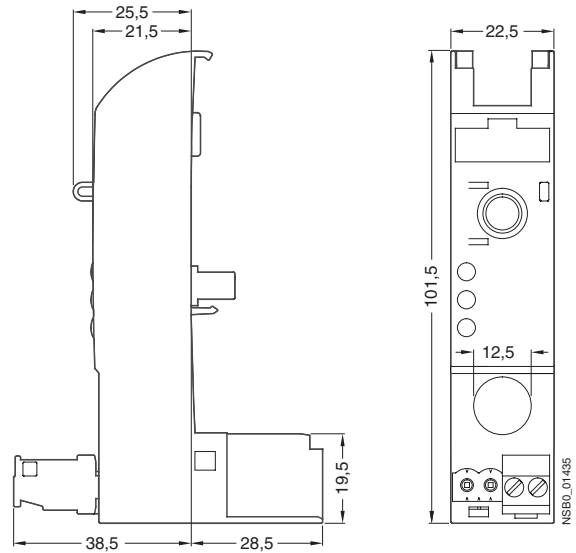

Extended load monitoring
3RF29 .0-0GA..

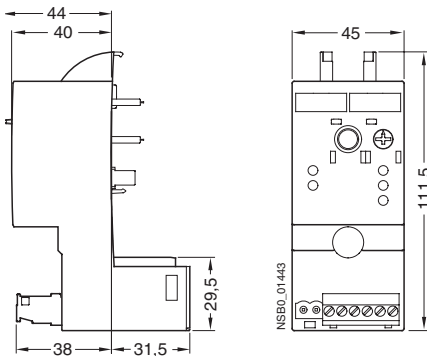

Power controllers
3RF29 .0-0HA..

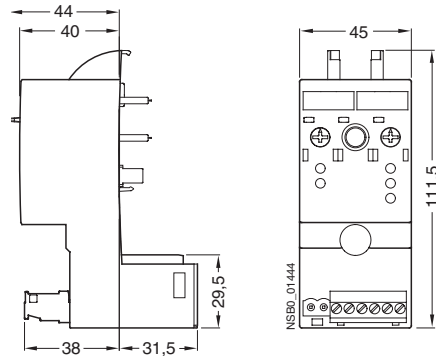

Accessories for SIRIUS SC semiconductor switching devices

Terminal cover for SIRIUS semiconductor switching devices

3RF29 00-3PA88

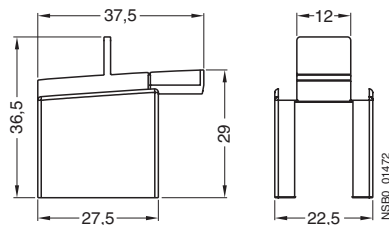

SIRIUS SC Semiconductor Switching Devices

Semiconductor Relays and Contactors, Function Modules

Project planning aids

3

Circuit diagrams

SIRIUS SC semiconductor relays

DC version

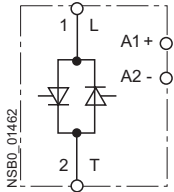

AC version

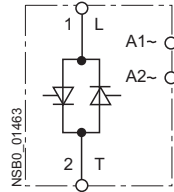

SIRIUS SC semiconductor contactors

DC version

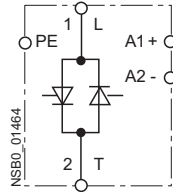

AC version

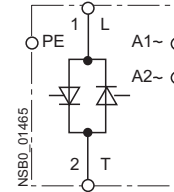

Function modules for SIRIUS SC semiconductor switching devices

Converters

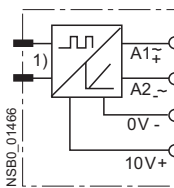

Basic load monitoring

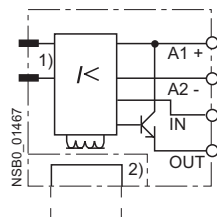

Extended load monitoring

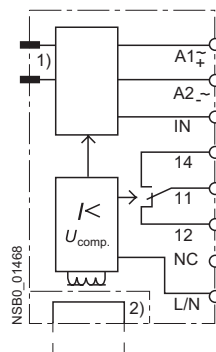

Power controllers

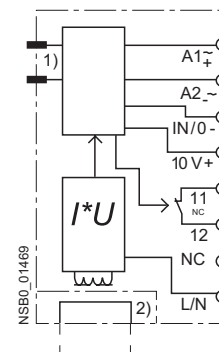

- 1) Internal connection.
- 2) Straight-through transformer.

SIRIUS SC semiconductor relays

Typical circuit diagram

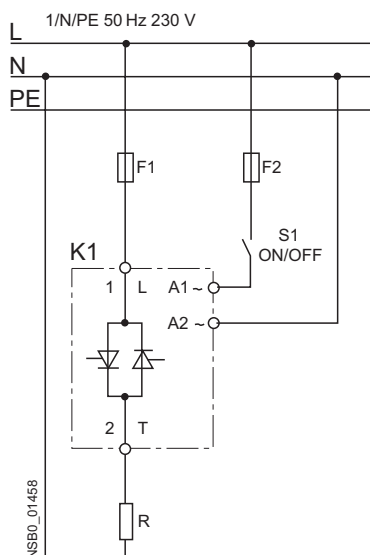

SIRIUS SC Semiconductor Switching Devices

Semiconductor Relays and Contactors, Function Modules

Project planning aids

Function modules for SIRIUS SC semiconductor switching devices

Converters Typical circuit diagram

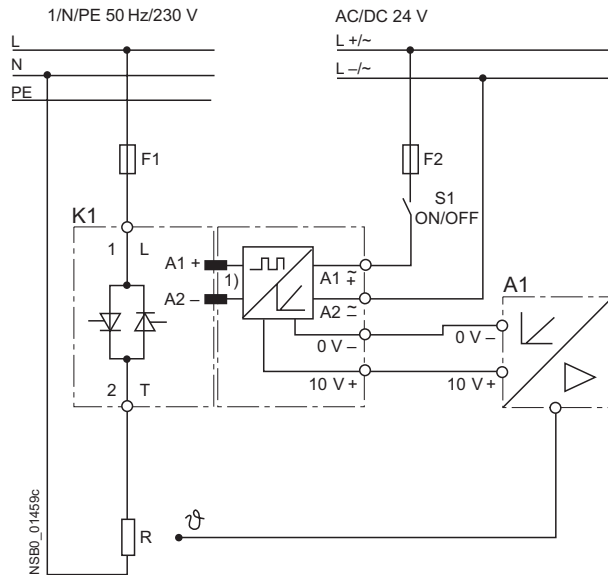

Basic load monitoring Typical circuit diagram

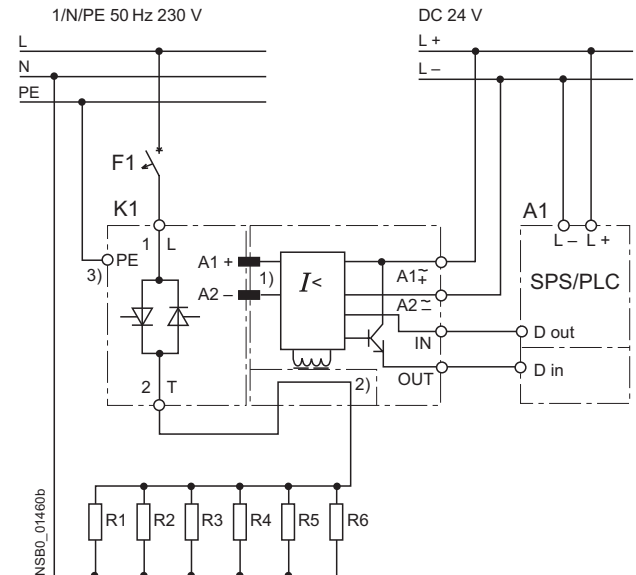

Extended load monitoring Typical circuit diagram

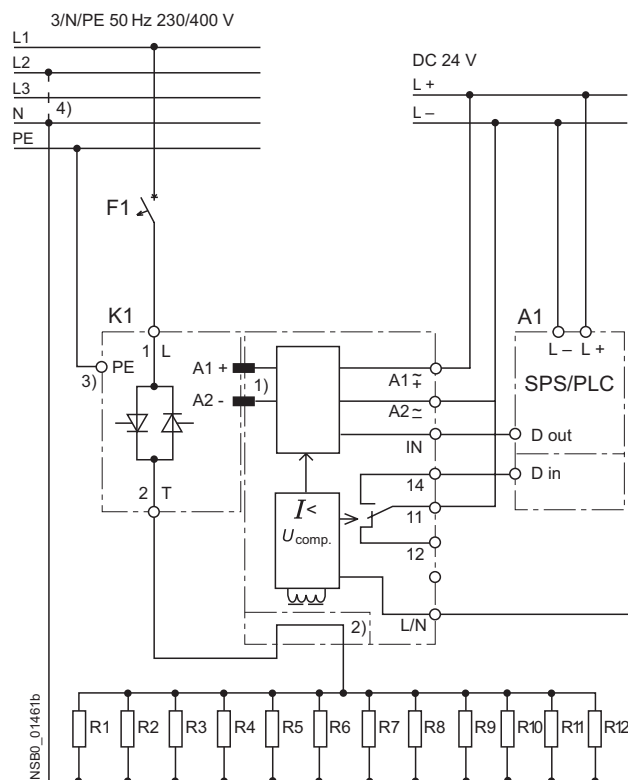

Power controllers Typical circuit diagram

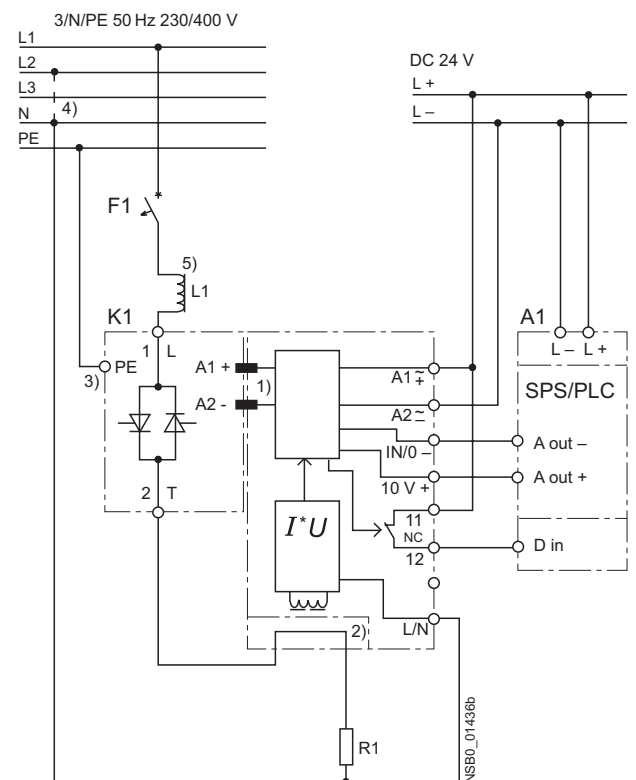

- 1) Internal connection.
- 2) Straight-through transformer.
- 3) PE/ground connection for semiconductor contactors according to installation regulations.
- 4) Connection of contact L/N to N conductor or a second phase according to the rated operational voltage of the function module.
- 5) In order to observe the limit values of the conducted interference voltage for generalized phase control, a choke rated at at least 200 μ H must be included in the load circuit.