

- 1 Energy transducer inputs (-X21)
- 2 N-/g-current sensor input (-X24)
- 3 Current sensor inputs (-X20)
- 4 CubicleBUS terminal
- 5 Ground terminal (-X100) (underside)

9 Disconnect the cable harnesses attached to the -X20 and -X24 connectors

Installing the EMC filter

10 Seat the EMC filter in the pocket behind the trip unit, and attach it with the provided self-tapping screw.



Mounting plate for cable harness

EMC Filter

Self-tapping screw

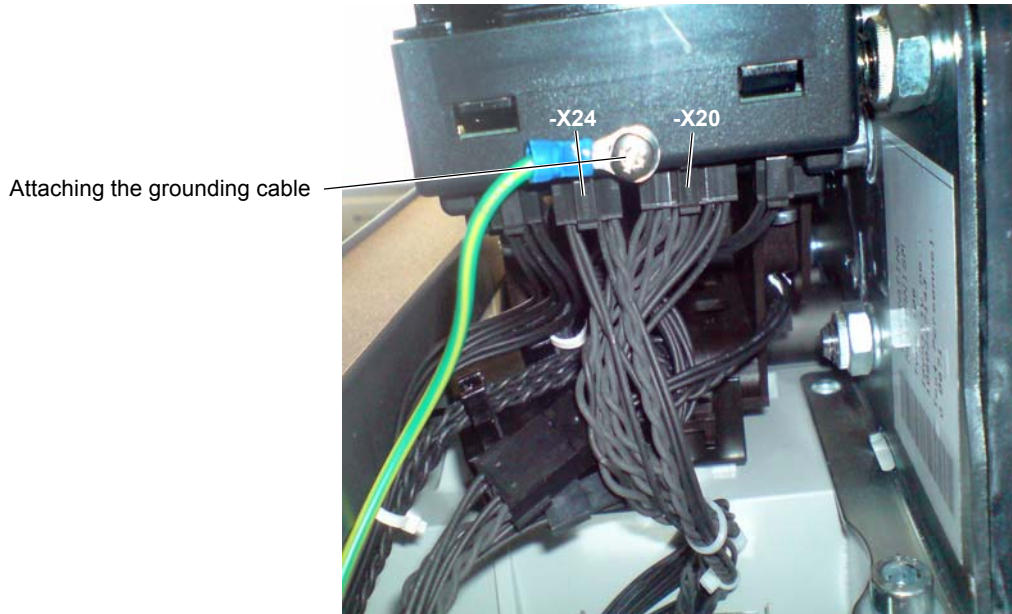
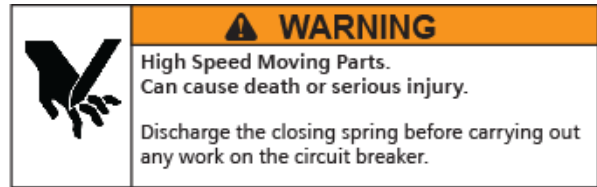
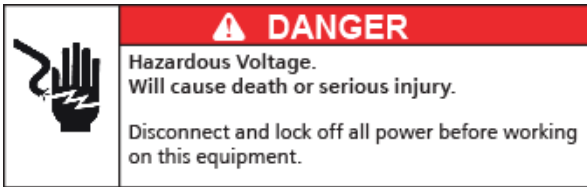

- 11 Attach the yellow-green grounding cable to the X100 screw on the bottom of the electronic trip unit (the screw is provided with the trip unit).
- 12 Connect the -X20 connector from the existing harness to the -X20a (female connector) from the EMC filter. Likewise, connect the -X24 connector from the existing harness to the -X24a (female connector) from the EMC filter.

Extra cable harness length has been provided for ease of assembly. Cable slack may be routed into the cable duct behind the trip unit compartment, and below the current sensors. The following figure demonstrates this (notice the EMC filter harness, and the -X20 and -X20a connectors tucked into the left corner of the cable duct).

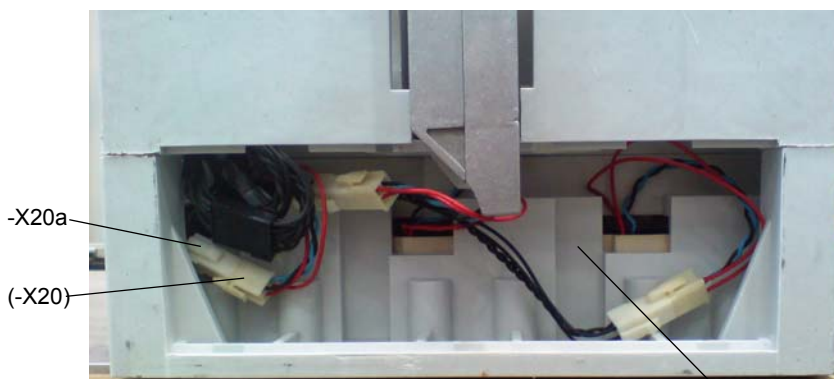

Cable duct (cover plate removed)

- 13 Connect the -X20 and -X24 connectors from the EMC filter to the corresponding sockets in the trip unit.
- 14 Re-install the electronic trip unit and the front cover, following the Steps 1 - 8 in reverse order.
- 15 Test and document the EMC filter installation with the WLTS Hand-held Trip Unit Test Set, in accordance with Siemens instruction "WLTS Hand-Held Test Set Application Guide," (document number CBBR-WLTS-A-0716).

Wiring schematics

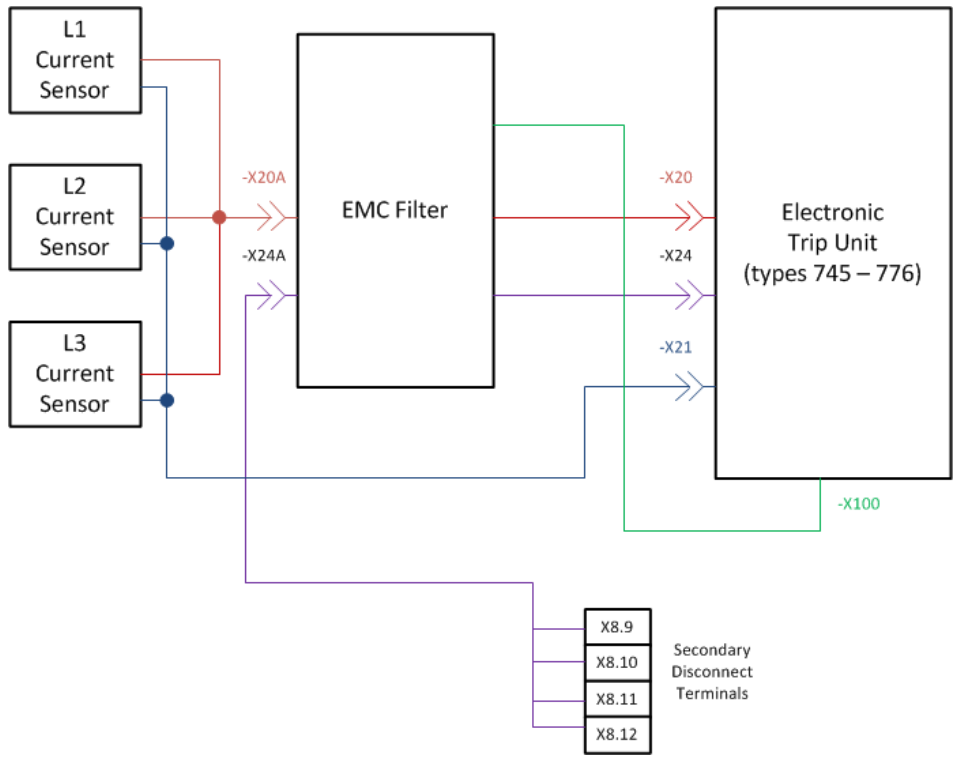

3-Pole Circuit Breakers

FS I, II, and III
 Neutral-CT: external
 Ground fault-CT: external

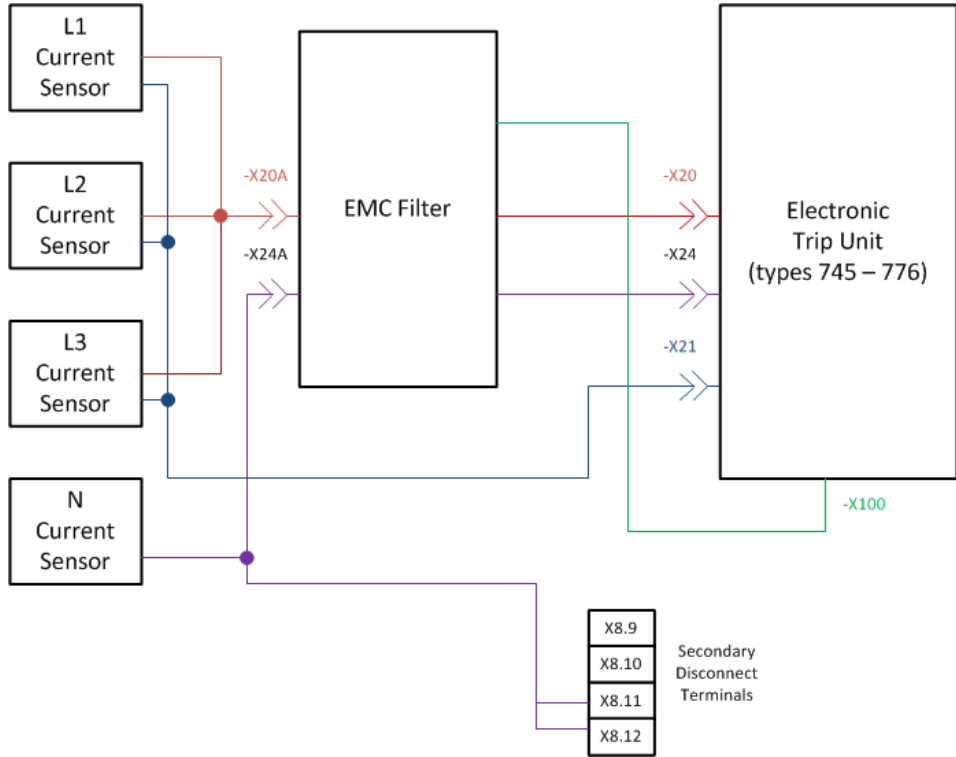

4-Pole Circuit Breakers

FS II and III
 Neutral-CT: internal
 Groundfault-CT: external

Technical Support:

Toll Free: 1-800-241-4453

Internet: www.siemens.com/powerdistribution