

Catalog Number: 48104-82WI

Features and Ratings

- Ringless Type Meter Socket
- 320A Continuous, 400A Max., 600V AC
- Outdoor Enclosure (NEMA Type 3R)
- Painted G90 Steel Enclosure
- 1 Phase, 3-Wire, Commercial Socket
- 4 Jaw Meter Socket
- Meter Socket Type HQ-4SWT
- For Overhead & Underground Service
- HD Type Hub Opening w/Large Coverplate
- Lever Bypass
- Side Wired

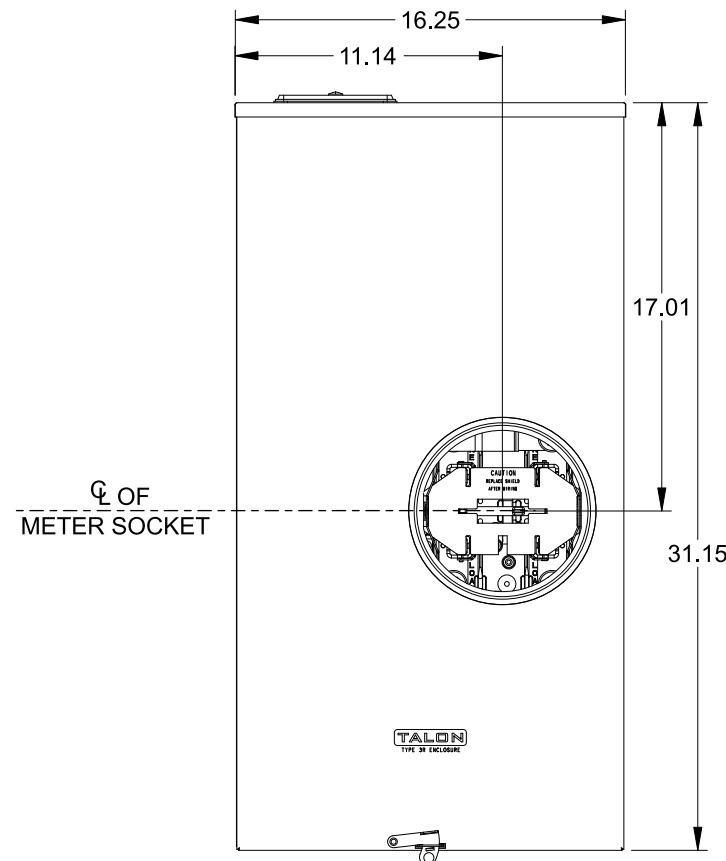
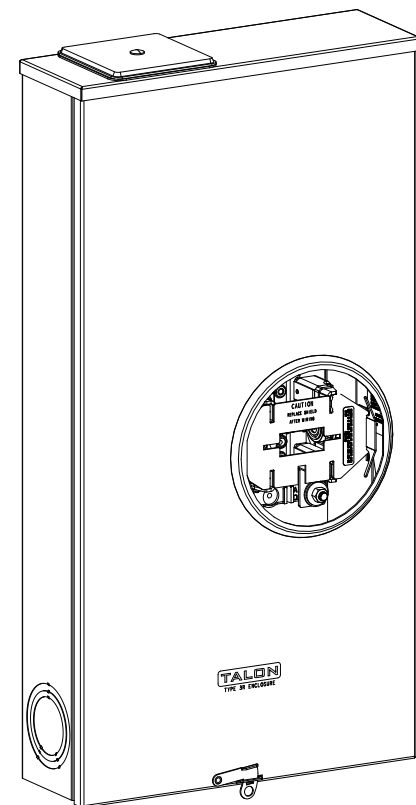
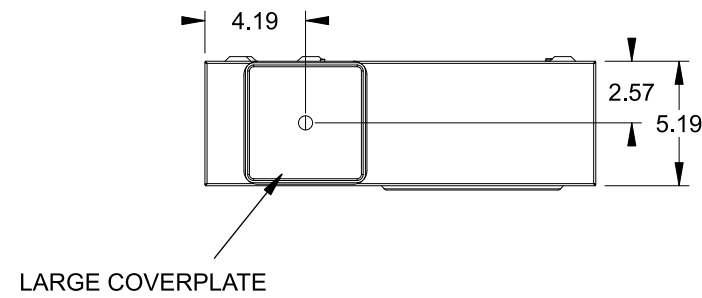

VIEW SHOWN WITH COVER REMOVED

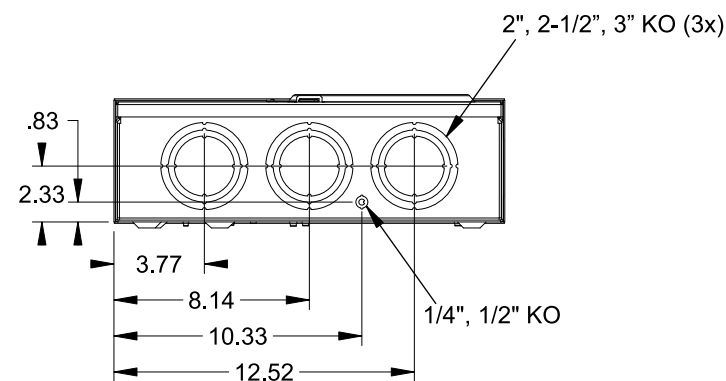
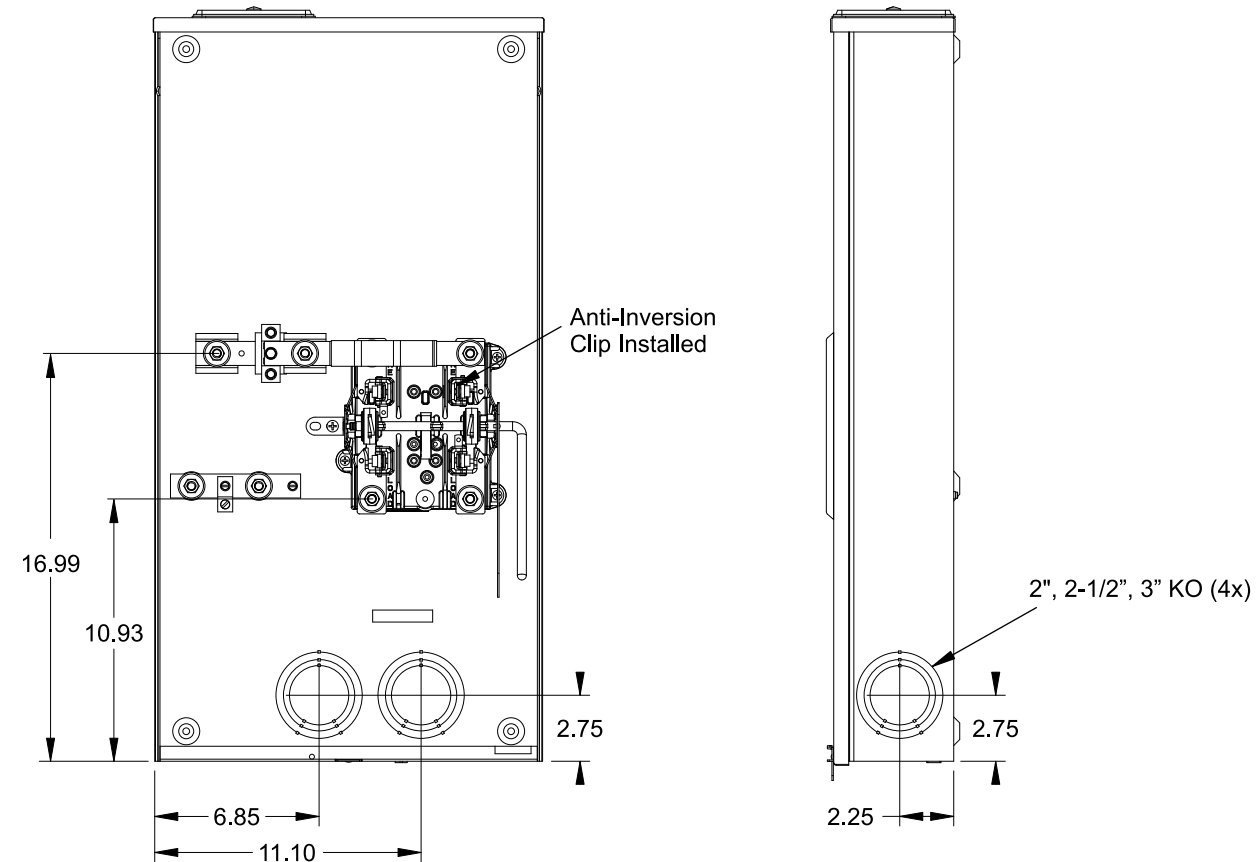

Accessories

CONDUIT HUBS (HD Type)	
TRADE SIZE	CATALOG No.
3 INCH	EC56856 or H56856-2
3-1/2 INCH	EC56857 or H56857-2
4 INCH	EC56858 or H56858-2
Hub Cover Plate	EC56933 or H56933S

Meter Opening Cover Plate
Cat No: H659-0162

Connectors, Wire Sizes and Torques

RECOMMENDED OR INSTALLED CONNECTORS
(TIGHTENING TORQUE FOR CONNECTOR MOUNTING NUTS IS 300 LB-IN)

LOCATION	PART NO.	WIRE SIZE	HEX	TORQUE
LINE	H60162	#4 AWG-600 kcmil (2)#1/0 AWG-250 kcmil	1/2"	500 LB-IN
LINE	H56476	#3/0 AWG-800 kcmil	1/2"	500 LB-IN
LINE	H56732	(2)#4 AWG-350 kcmil	5/16"	275 LB-IN
LOAD	H60162	#4 AWG-600 kcmil (2)#1/0 AWG-250 kcmil	1/2"	500 LB-IN
LOAD	H56476	#3/0 AWG-800 kcmil	1/2"	500 LB-IN
LOAD	H56732-2	(2)#6 AWG-350 kcmil	5/16"	275 LB-IN
NEUTRAL	H60162	#4 AWG-600 kcmil (2)#1/0 AWG-250 kcmil	1/2"	500 LB-IN
NEUTRAL	H56476	#3/0 AWG-800 kcmil	1/2"	500 LB-IN
NEUTRAL	H56732-2	(2)#6 AWG-350 kcmil	5/16"	275 LB-IN
GROUND*	67554A	#14 - 2/0 AWG	..	50 LB-IN

* indicates factory installed connectors

© 2018 Copyright Siemens Industry, Inc.

TALON
Meter Socket

Description: **320A Cont, 4 Jaw, HQ-4SWT, 600V AC, Painted Steel Enclosure**

JEL 5/10/18 DO NOT SCALE DRAWING Dwg No: **48104-82WI**