

10. Reference fig. 9 - Installing the Branch Neutral Lug (item 11) in a Switchboard. The Branch Neutral is located at the bottom of the "Z-rails", or mirrored at the top depending upon the feed cable location. Two (2) different Neutral lug assemblies are included in the kit, be sure to install the type pictured below. The Neutral lug assemblies can be mounted, as shown, or on any available hole of the Branch Neutral depending on cable feed location. Torque all hardware as specified on the rear of the deadfront.

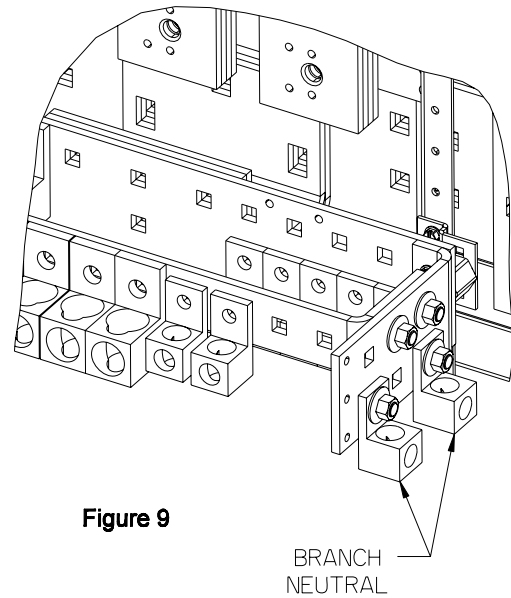

Figure 9

11. Reinstall the dead front using the breaker cover plate supplied with this kit. Other filler plates may be required for proper fit. See filler plate kits listed on the rear of the dead front.

# SIEMENS

## Switchboard/Powerpanel Kit SQJD/6QJ2/SQJ for Branch Mounting Type QJ Breakers

Installation  
Instructions

## Installation Instructions

The following instructions are for the installation of Siemens QJ Breakers in switchboards or shallow/deep panelboards. This kit will require 5" of unit space. The parts provided in this kit are for a connection to a 3 phase / 3 wire or 3 phase / 4 wire system.



4. Open the shipping box and check the hardware against the following list.

ITEM	DESCRIPTION	QTY.
1	INSTALLATION INSTRUCTIONS	1
2	A/C STRAP	2
3	B STRAP	1
4	STRAP - SECTION BUS HARDWARE KIT	1
5	A/C LINK BAR	2
6	B LINK BAR	1
7	QJ MOUNTING BRACKET	2
8	5" QJ COVER PLATE	1
9	CARD HOLDER	2
10	CIRCUIT ID CARD	1
11	NEUTRAL LUG ASS'Y	2
12	1/4-20 X 3/8" SCREW	6
13	1/4-20 X 5/8" SCREW	12
14	1/4-20 X 2-3/4" SCREW	4
15	BOX	1
16	CARTON LABEL	1

5. Reference fig. 4 - The first items to be installed are the line straps (items 2 and 3). Locate two 0.228" diameter holes on the B  $\phi$  of the section bus, 1-1/4" down from the top of the 5.0" unit space selected. Insert two 1/4-20 thread forming screws (see the mounting hardware kit for the proper length) through the two holes in the B strap (item 3) and then into the 0.228" diameter holes on the B  $\phi$  bus and tighten. Repeat this step to install the A  $\phi$  strap (item 2) onto the A  $\phi$  bus. To install the C  $\phi$  strap (item 2), locate two 0.228" diameter holes on the C  $\phi$  bus 2.50" below the mounting screws of the A  $\phi$  and B  $\phi$  straps. Insert two more of the 1/4-20 thread forming screws through the two holes in the strap and then into the 0.228" diameter holes in the C  $\phi$  section bus. Torque all screws to the values specified on the rear of the dead front.

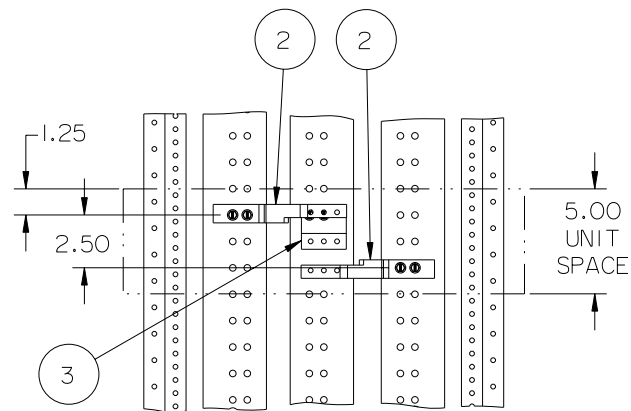

Figure 4

1. Lock off power supplying this equipment before working on it.
2. Reference fig. 1 - Remove the (2) gutter covers and cover plates.

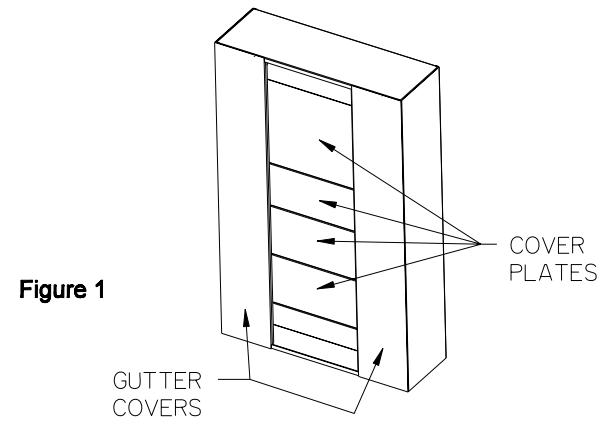

Figure 1

3. Reference fig. 2 - To mount a QJ Breaker, 5" of empty unit space is required. To locate the mounting position, measure from the top dead front support to the top of the empty unit space filler on the dead front. Transfer this dimension from the dead front support along the Z-rail and mark. This will be the unit space as shown on fig. 4. After marking the Z-rail, remove the dead front.

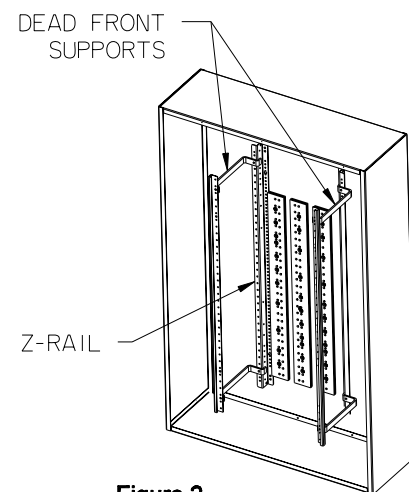

Figure 2

6. Reference fig. 5 - The QJ mounting brackets (item 7) are to be mounted. Locate a 0.228" diameter hole on the left Z-rail 5/8" below the mounting screws of the A  $\phi$  strap. Insert one 1/4-20 X 3/8" screw (item 12) through the 0.312" diameter hole in the QJ mounting bracket and then into the hole in the Z-rail and tighten. Orient the QJ mounting bracket as shown, insert another 1/4-20 X 3/8" screw through the second 0.312" diameter hole in the QJ mounting bracket and then into a 0.228" diameter hole in the Z-rail and tighten. Repeat the same steps to install the second QJ mounting bracket onto the right hand Z-rail. Torque all screws as specified on the rear of the dead front.

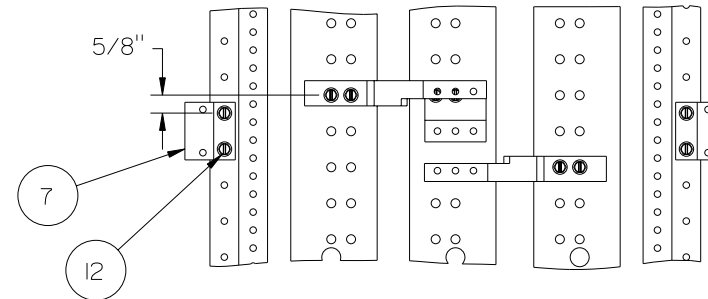

Figure 5

7. Reference fig. 6 - Install the link bars (items 5 and 6). Insert two 1/4-20 X 5/8" screws (item 13) through the two 0.281" diameter holes in the B link bar (item 6) and into the two 0.228" diameter holes in the B  $\phi$  strap and tighten. Repeat this step to mount the two A/C link bars (item 5) to the A  $\phi$  and C  $\phi$  straps, orienting the link bars as shown so as to have 1.50" vertically between centers of the bars. Torque all screws as specified on the rear of the dead front.

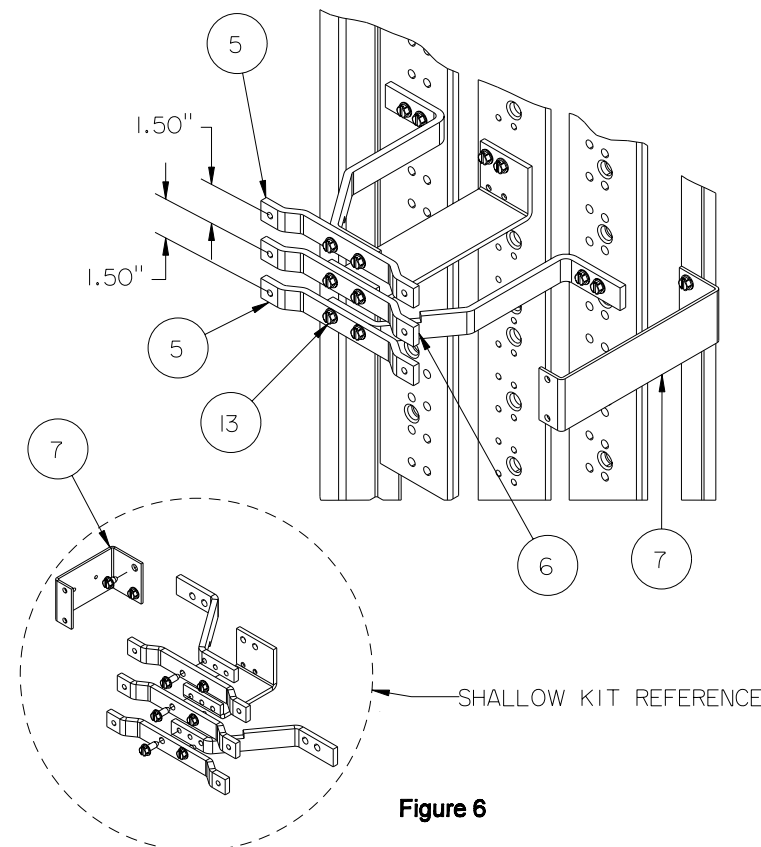

Figure 6

8. Reference fig. 7 - Install a circuit breaker by inserting one 1/4-20 X 5/8" screw (item 13) into each of the three contacts on the line side of the breaker and into the 0.228" diameter holes at the left end of the A  $\phi$ , B  $\phi$  and C  $\phi$  link bars and tighten. Insert two 1/4-20 X 2-3/4" thread forming screws (item 14) into the two mounting holes at the load side of the breaker and into the two 0.228" diameter holes in the QJ mounting bracket and tighten. Torque all connections to the values as specified on the rear of the dead front.

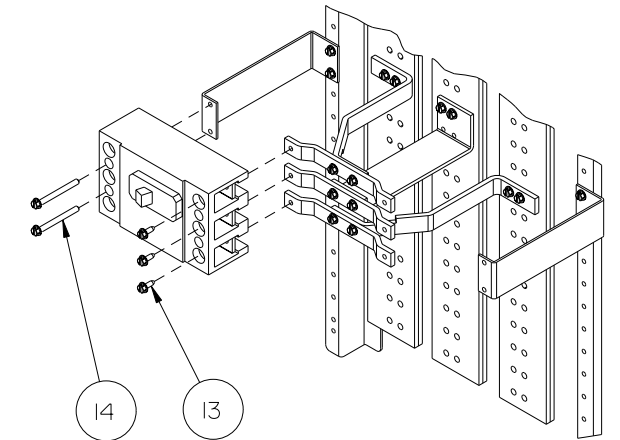

Figure 7

NOTE: If a Branch Neutral Lug Assembly is NOT Required Skip To Step II.

NOTE: For Switchboard Applications Skip To Step IO

9. Reference fig. 8 - Installing the Branch Neutral Lug (item 11) in a panelboard. The Branch Neutral is located at the bottom of the "Z-rails", or mirrored at the top depending upon the feed cable location. Two types of Neutral lug assemblies are included in the kit, be sure to install the kind pictured below. The Neutral Lug assemblies can be mounted, as shown, on either side of the Branch Neutral depending on cable feed location. Torque all hardware as specified on the rear of the dead front.

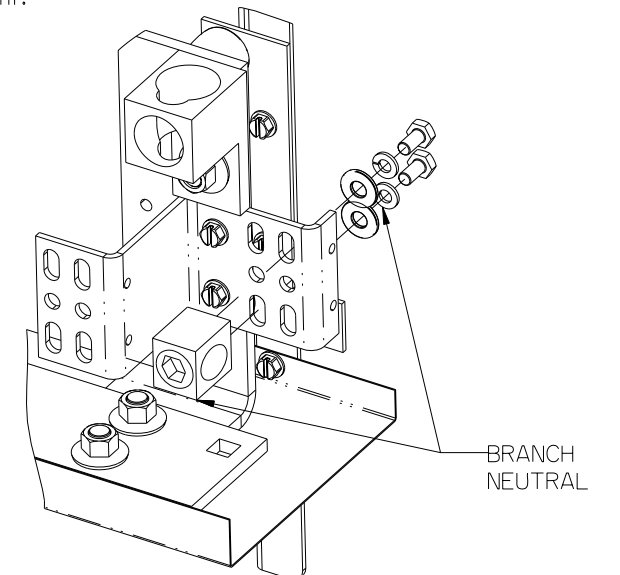

Figure 8