

Dwg. No. 12-5719 Sht 1 of 1
 Rev. 10
 Autocad Filename:

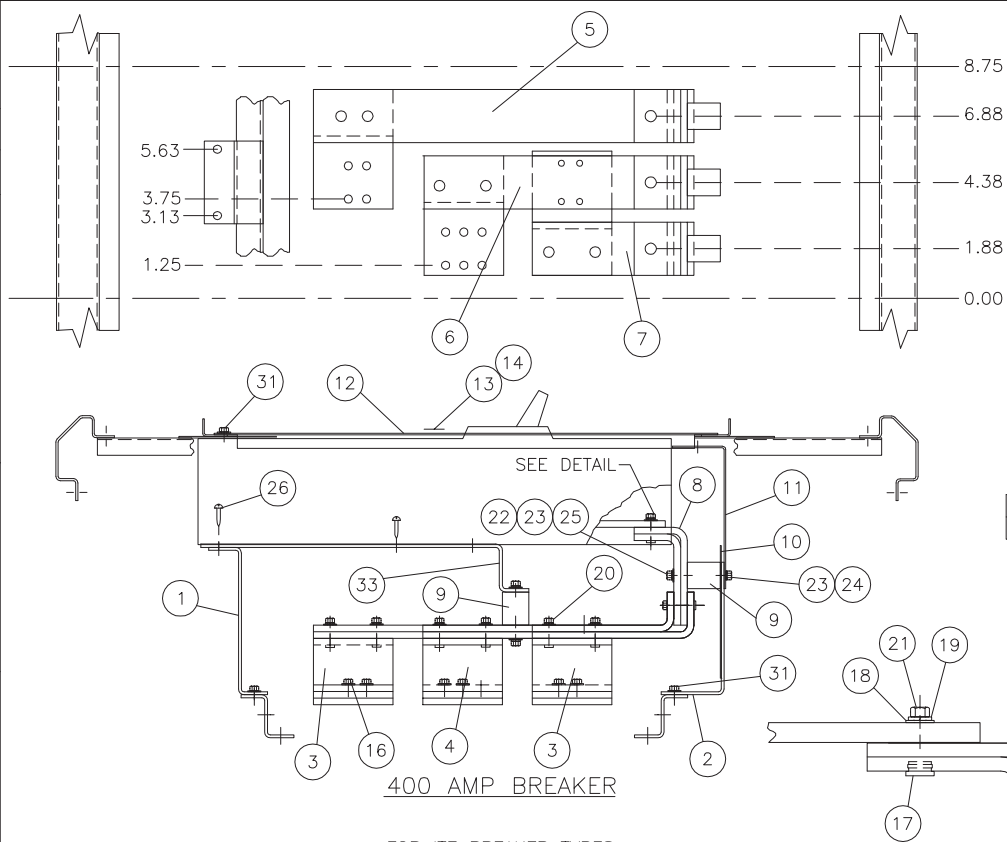

-01 CAT# 6CLJ1
 -02 CAT# SCJD

PC. -01 ASSY. USED ON STRAP KIT 6CLJ1
 PC. -02 ASSY. USED ON STRAP KIT SCJD

FOR ITE BREAKER TYPES: CLJ, CJD6

TORQUE VALUES:

- ①⑥ - 72 IN./LBS.
- ②⑨ - 20 FT./LBS.
- ②①②① - 12 FT./LBS.

⚠ DANGER

Hazardous voltage. Will cause death or serious injury.

Keep out. Qualified personnel only. Disconnect and lock off all power before working on this equipment.

Rev	C.N.	Date
10	1C-831B	7-31-06
9	1C-831A	04-12-04
8	1B-908	5-8-95
7	1B-359	11-11-92
6	1A-939	7-22-91
5	1A-280	11-30-90
4	1A-077	6-08-89
3	1A-066	2-16-89
2	8A-093	7-15-88
1	8A-071	
0	8A-001	3-30-87

Chk	JRM	Date	3-30-87
Apvd	SH	Date	9-13-91

Confidential - Property of
Siemens Industry, Inc.
Norcross, GA

CJD FRAME MOUNT
SERIES 6 - BRANCH

Dwg No. 12-5719 Rev. 10

Scale NONE Sheet 1 of 1

FOR USE ON SERIES 5 OR 6 DISTRIBUTION SECTIONS, CDP-5, CDP-6, VB-5, VB-6, FCI, FCII, SB1, SB2 & SB3.

IF EXISTING EQUIPMENT IS TYPE CDP-5, VB-5, OR FC20 THE VERTICAL BUS WILL BE PRE-PUNCHED WITH .406 DIAMETER HOLES. IN THESE CASES USE SERIES 5 ADAPTOR KIT FURNISHED WITH THIS KIT. SEE REVERSE SIDE FOR INSTRUCTIONS.

31-1187-01 Rev. 2

Siemens Industry, Inc.
Norcross, GA

CAT. NO. 6CLJ1

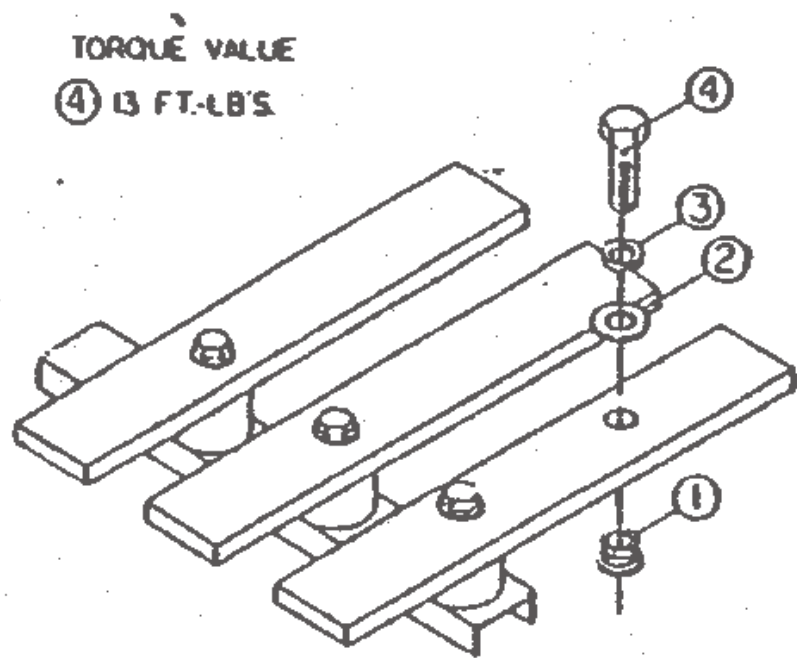

⚠ DANGER

Hazardous voltage. Will cause death or serious injury.

Keep out. Qualified personnel only. Disconnect and lock off all power before working on this equipment.

Apvd	DSH	6-15-92	ITEM	DESCRIPTION	PC. NO.	QTY.
			1	5/16 INSERT	11-1620-04	12
			2	5/16 FLAT WASHER	11-1615-06	12
			3	5/16 LOCK WASHER	11-1618-04	12
			4	5/16-18 X 1 1/4 HHMS	11-1566-07	12
			5	FAST LATCH SCREW BAG	11-A-1821-01	1
			6	▲ ID CARD	31-1160-02	1
			7			
			8			
			9			
			10			
			11			
			12			
			13			
			14			
			15			
			16			
			17			
			18			
			19			
			20			
			21			
			22			
			23			
			24			
			25			
			26			
			27			
			28			
			29			
			30			
			31			
			32			
			33			
			34			
			35	For use in adapting Series 6 Mounting Kits to be used in Series 5 type panel construction.		
			36			
			37	Series 5 construction has .406 dia. holes in interior horizontal bus.		
			38			
			39			
			40	(1) Use 5/16-18 insert in bus being certain that the flange on insert is pulled up flush with back of bus bar.		
			41			
			42			
			43	(2) Drill out appropriate holes in branch bus minimum of .344 dia. to accommodate 5/16-18 bolts.		
			44			

Confidential - property of
Siemens Industry, Inc.
Norcross, GA

SERIES 5 ADAPTOR KIT

11-5570-02
Dwg No.

3
Rev.

FOR USE ON SERIES 5 OR 6 DISTRIBUTION SECTIONS, CDP-5, CDP-6, VB-5, VB-6, FCI, FCII, SB1, SB2 & SB3.

IF EXISTING EQUIPMENT IS TYPE CDP-6, VB-6, FCI OR FCII THE VERTICAL BUS WILL BE PRE-PUNCHED WITH .228 DIAMETER HOLES. IN THESE CASES USE SERIES 6 BRANCH BUS PARTS LIST ON REVERSE SIDE.

CAT. NO. 6CLJ1