

REVISION	DATE	BY	DATE	BY
			16/06/27	LC

Confidential - Property of <b>Siemens Industry, Inc.</b>	
CUSTOMER	
ORDER NO.	DWG. NO.
	3F3Y075BLN3HD100 SH 1 OF 2

# SIEMENS

<p>CATALOG NO. 3F3Y075BLN3HD100</p> <p>SERIAL NO. SERIES H</p> <p>75 kVA 60 Hz 3 PHASE</p> <p>4.6 % IMP AT 100 °C</p> <p>80 °C RISE 30 °C AVG. AMBIENT</p> <p>220 °C TEMP CLASS 40 °C MAX. AMBIENT</p> <p>PRIMARY ( H1 H2 H3 ) 480 V 10 kV BIL</p> <p>SECONDARY ( X1 X2 X3 ) 208Y/120 V 10 kV BIL</p> <p>NEUTRAL ( X0(200%) ) V</p> <p>WINDING MATERIAL AL</p> <p>ENCLOSURE TYPE 3R WEIGHT 835 LBS</p> <p>ENERGY EFFICIENCY EXCEEDS NEMA TPI-2002 DOE 10 CFR PART 431:2016</p> <p>SPACINGS BETWEEN ANY VENTILATED ENCLOSURE PANEL AND ANY ADJACENT WALL SHALL BE A MINIMUM OF 5 INCHES EXCEPT WHEN WALL MOUNTED USING APPROVED WALL MOUNTING KIT ELECTROSTATIC SHIELD</p> <p>SUITABLE FOR INDOOR OR OUTDOOR LOCATIONS BEFORE HANDLING, INSTALLING AND OPERATING; SEE INSTRUCTION MANUAL</p> <p>NEMA Class ANN Dry Type Harmonic Mitigating Transformer Siemens Industry, Inc. Norcross, GA 6840703e</p>	 <p>ANGULAR DISPLACEMENT 0°</p> <p>VOLTS CONNECT</p> <table style="margin-left: 20px;"> <tr><td>1</td><td>504</td></tr> <tr><td>2</td><td>492</td></tr> <tr><td>3</td><td>480</td></tr> <tr><td>4</td><td>468</td></tr> <tr><td>5</td><td>456</td></tr> <tr><td>6</td><td>444</td></tr> <tr><td>7</td><td>432</td></tr> </table>	1	504	2	492	3	480	4	468	5	456	6	444	7	432	<p>TYPE K</p> <p>UL LISTED</p> <p>DRY TYPE TRANSFORMER E112313</p> <p>LR 3902</p> <p>SEISMIC QUALIFICATIONS, FLOOR MOUNT ONLY OSP-0136-10 IBC 2012/ASCE 7-10 SDS&lt;=2.0g z/h=1 p=1.5</p>
1	504															
2	492															
3	480															
4	468															
5	456															
6	444															
7	432															

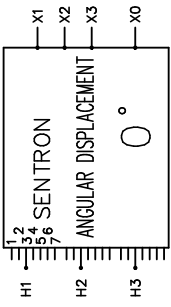

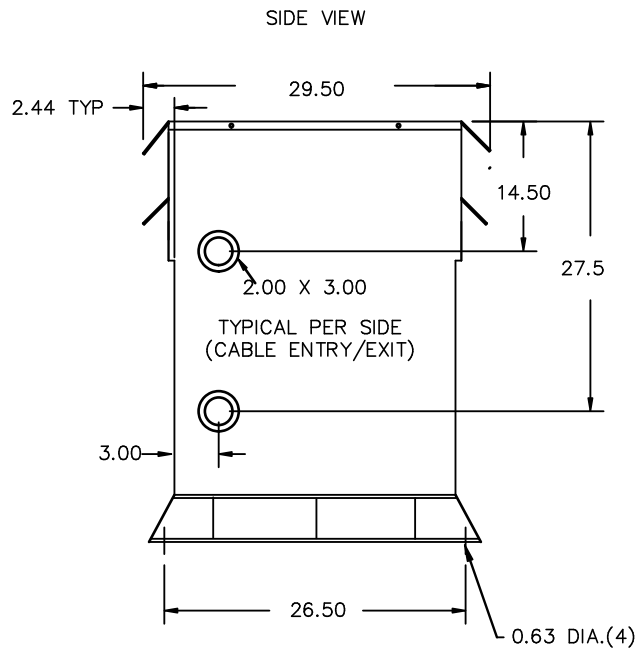
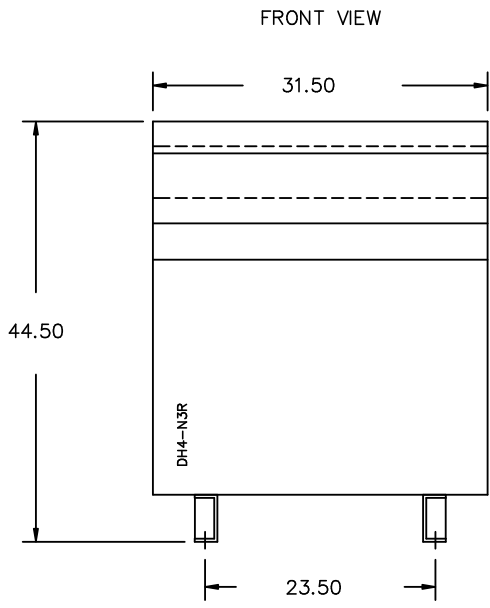

All Dimensions in inches

ENCLOSURE COLOR :ANSI 61 GREY – OUTDOOR

H.V.1. TERMINAL DETAIL

L.V.1. TERMINAL DETAIL

MECHANICAL TYPE LUGS INCLUDED  
SUITABLE FOR #2/0-14 CU/AL  
CONDUCTORS  
1 CONDUCTOR PER PHASE

MECHANICAL TYPE LUGS INCLUDED  
SUITABLE FOR 600MCM-2 CU/AL  
CONDUCTORS  
1 CONDUCTOR PER PHASE

CUSTOMER NOTES:

- HV1 TERMINATED AT BOTTOM FRONT
- LV1 TERMINATED AT TOP FRONT
- 200% RATING NEUTRAL

Confidential – Property of  
**Siemens Industry, Inc.**

REVISION	DATE	BY	DATE	BY
		DRAWN	16/06/27	LC
		CHEK'D		
		VERIF'D		

CUSTOMER	
ORDER NO.	DWG. NO. 3F3Y075BLN3HD100 SH 2 OF 2

0.4 Icen 2016/06/27 16:37