

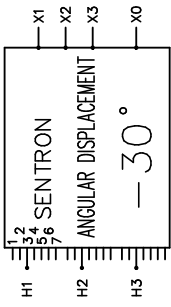

| REVISION | DATE     | BY | DATE     | BY |
|----------|----------|----|----------|----|
|          |          |    | 16/06/03 | LC |
|          |          |    |          |    |
| 1        | 17/01/30 | LC |          |    |

|   |              |           |
|---|--------------|-----------|
| Confidential - Property of<br><b>Siemens Industry, Inc.</b> |              |           |
| CUSTOMER  |              |           |
| ORDER NO.   | DWG. NO.     | 1         |
|   | 3F3Y075HD130 | SH 1 OF 3 |

# SIEMENS

|  |   |     |   |     |   |     |   |     |   |     |   |     |   |     |   |  |
|--|---|-----|---|-----|---|-----|---|-----|---|-----|---|-----|---|-----|---|--|
| <p>CATALOG NO. 3F3Y075HD130</p> <p>SERIAL NO. SERIES H</p> <p>75 kVA 60 Hz 3 PHASE</p> <p>3.8 % IMP AT 170 °C</p> <p>150 °C RISE 3 °C AVG. AMBIENT</p> <p>220 °C TEMP CLASS 40 °C MAX. AMBIENT</p> <p>PRIMARY ( H1 H2 H3 ) 480Y V 10 kV BIL</p> <p>SECONDARY ( X1 X2 X3 ) 208Y/120 V 10 kV BIL</p> <p>NEUTRAL ( X0(200%) ) V</p> <p>WINDING MATERIAL AL</p> <p>ENCLOSURE TYPE 3R WEIGHT 900 LBS</p> <p>ENERGY EFFICIENCY EXCEEDS NEMA TPI-2002 DOE 10 CFR PART 431:2016</p> <p>SPACINGS BETWEEN ANY VENTILATED ENCLOSURE PANEL AND ANY ADJACENT WALL SHALL BE A MINIMUM OF 5 INCHES EXCEPT WHEN WALL MOUNTED USING APPROVED WALL MOUNTING KIT ELECTROSTATIC SHIELD</p> <p>SUITABLE FOR INDOOR OR OUTDOOR LOCATIONS BEFORE HANDLING; INSTALLING AND OPERATING; SEE INSTRUCTION MANUAL</p> <p>NEMA Class ANN Dry Type Harmonic Mitigating Transformer Siemens Industry, Inc. Norcross, GA 6840703e</p> |  <p>ANGULAR DISPLACEMENT<br/>-30°</p> <p>VOLTS CONNECT</p> <table style="width: 100%;"> <tr><td>504</td><td>1</td></tr> <tr><td>492</td><td>2</td></tr> <tr><td>480</td><td>3</td></tr> <tr><td>468</td><td>4</td></tr> <tr><td>456</td><td>5</td></tr> <tr><td>444</td><td>6</td></tr> <tr><td>432</td><td>7</td></tr> </table> | 504 | 1 | 492 | 2 | 480 | 3 | 468 | 4 | 456 | 5 | 444 | 6 | 432 | 7 | <p>TYPE K</p>  <p>LISTED</p> <p>DRY TYPE TRANSFORMER 7715 E112313 LR 3902</p> <p>SEISMIC QUALIFICATIONS, FLOOR MOUNT ONLY<br/>OSP-0136-10 IBC 2012/ASCE 7-10<br/>SDS&lt;=2.0g z/h=1 p=1.5</p> |
| 504  | 1   |     |   |     |   |     |   |     |   |     |   |     |   |     |   |  |
| 492  | 2   |     |   |     |   |     |   |     |   |     |   |     |   |     |   |  |
| 480  | 3   |     |   |     |   |     |   |     |   |     |   |     |   |     |   |  |
| 468  | 4   |     |   |     |   |     |   |     |   |     |   |     |   |     |   |  |
| 456  | 5   |     |   |     |   |     |   |     |   |     |   |     |   |     |   |  |
| 444  | 6   |     |   |     |   |     |   |     |   |     |   |     |   |     |   |  |
| 432  | 7   |     |   |     |   |     |   |     |   |     |   |     |   |     |   |  |



3F3Y075HD130

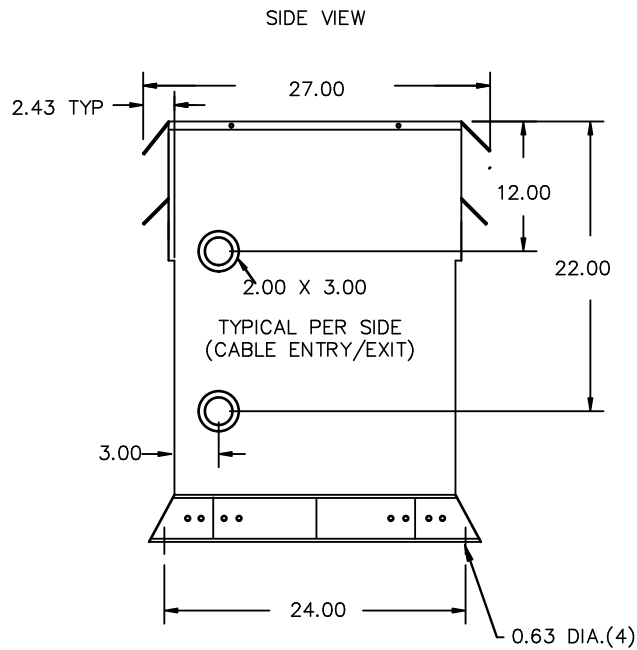
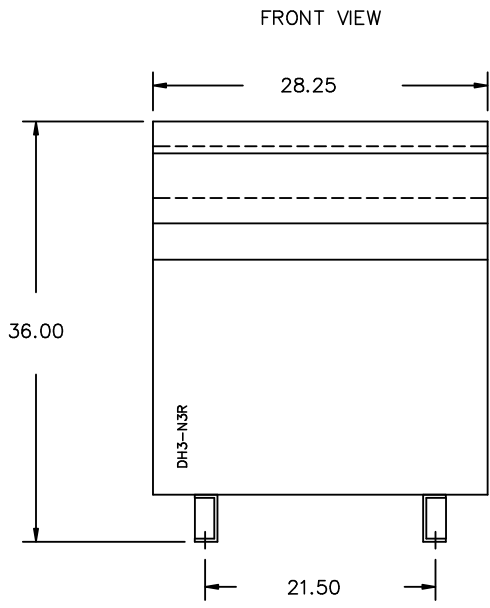

All Dimensions in inches

ENCLOSURE COLOR :ANSI 61 GREY – OUTDOOR

H.V.1. TERMINAL DETAIL

L.V.1. TERMINAL DETAIL

MECHANICAL TYPE LUGS INCLUDED  
SUITABLE FOR #2/0-14 CU/AL  
CONDUCTORS  
1 CONDUCTOR PER PHASE

MECHANICAL TYPE LUGS INCLUDED  
SUITABLE FOR 350MCM-6 CU/AL  
CONDUCTORS  
2 CONDUCTORS PER PHASE

CUSTOMER NOTES:

- HV1 TERMINATED AT BOTTOM FRONT
- LV1 TERMINATED AT TOP FRONT
- 200% RATING NEUTRAL,

Confidential – Property of  
**Siemens Industry, Inc.**

| REVISION | DATE           | BY       | DATE     | BY      |
|----------|----------------|----------|----------|---------|
|          |                | DRAWN    | 16/06/03 | LC      |
|          |                | CHEK'D   |          |         |
| 1        | CHANGED ADD P3 | 17/01/30 | LC       | VERIF'D |

|           |              |           |
|-----------|--------------|-----------|
| CUSTOMER  |              |           |
| ORDER NO. | DWG. NO.     | 1         |
|           | 3F3Y075HD130 | SH 2 OF 3 |

1.0 Icem 2017/01/30 11:47

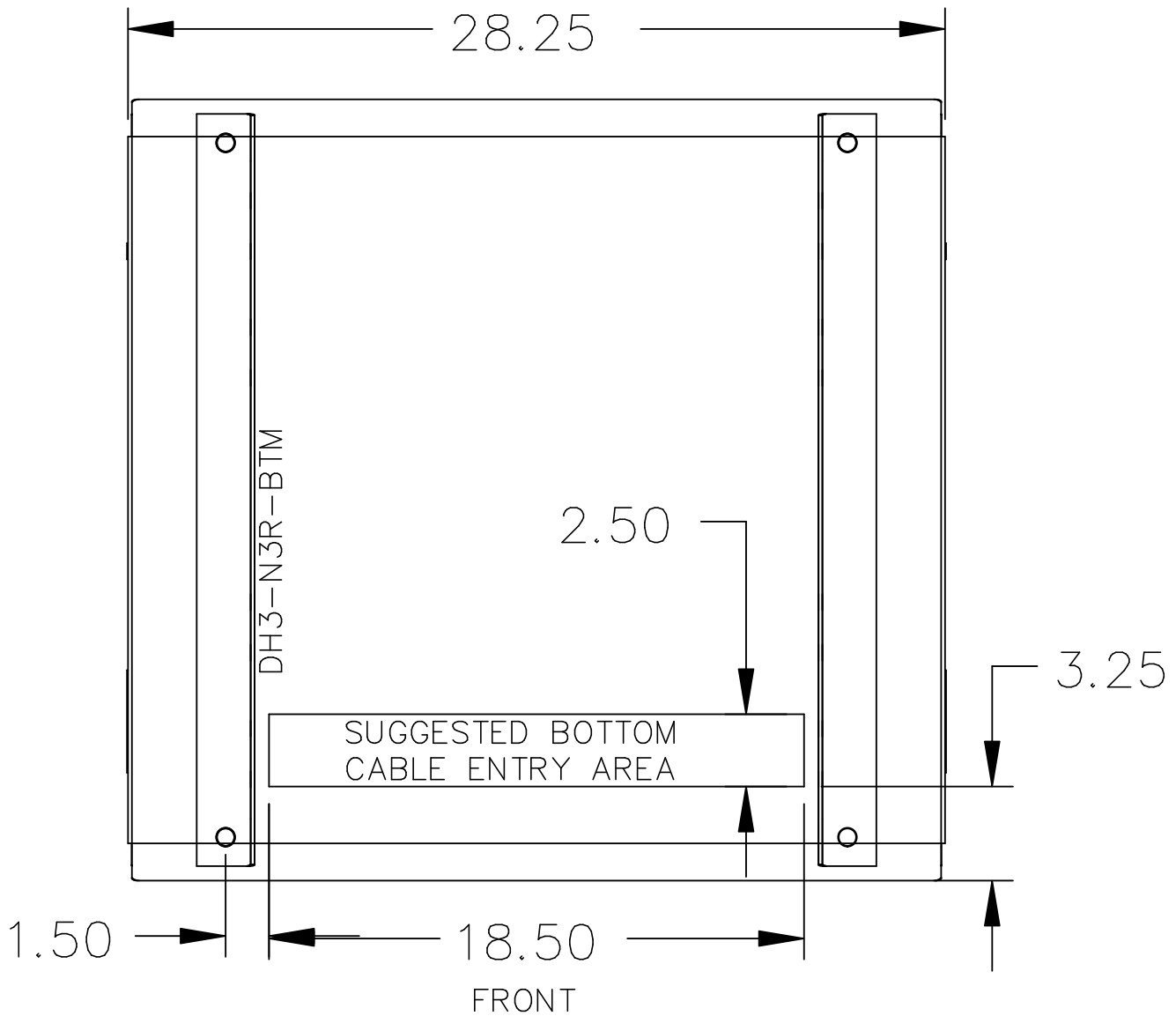

NOTE:  
 WHEN BOTTOM CABLE ENTRY IS OPTED, THE SPACE USED FOR CONDUITS IN THE FRONT OF THE TRANSFORMER SHOULD NOT OBSTRUCT MORE THAN 50% OF THE FRONT AIR INTAKE AREA DEFINED BETWEEN THE BOTTOM PLATE AND THE SUPPORTING LEGS.  
 SEE MANUAL FOR ADDITIONAL INFORMATION

Confidential - Property of  
 Siemens Industry, Inc.

| REVISION | DATE     | BY | DATE     | BY |
|----------|----------|----|----------|----|
|          |          |    | 16/06/03 | LC |
|          |          |    |          |    |
| 1        | 17/01/30 | LC |          |    |

|           |              |           |
|-----------|--------------|-----------|
| CUSTOMER  |              |           |
| ORDER NO. | DWG. NO.     | 1         |
|           | 3F3Y075HD130 | SH 3 OF 3 |