

TechTopics No. 121

Ground return currents in gas-insulated switchgear

The Siemens type 8DA (single-bus) and 8DB (double-bus) switchgear use single-phase construction. An advantage of this construction is that there is no possibility of a phase-to-phase fault inside the switchgear, and an extremely small chance of a single-phase to ground fault inside the switchgear. The construction makes the high-voltage components and buses essentially immune to the environment. A further feature is that current transformers (CTs) can be economic low-voltage toroidal type CTs, since the CT primary conductor is the bus bar inside the switchgear. The CT then has no dielectric stress imposed on it, eliminating the potential for a dielectric failure inside the CT. Further, since the switchgear housings are non-magnetic cast aluminum, mounting of the CTs outside the enclosure has no effect on the CT accuracy.

Questions have been asked about the operation of the CT in the event of a single phase to ground fault on the downstream load cables. Since the ground fault current will return along the cable and then through the switchgear structure, the concern is that the ground return current will offset the outgoing phase current and render the protective relay insensitive in the event of a single phase to ground fault downstream of the switchgear.

Simply stated, the ground current does return along the cable shield conductor, but it does not pass directly through the switchgear housing, and therefore the ground return current does not pass through the CT window.

The graphic in Figure 1 illustrates a typical circuit breaker unit of single-bus type 8DA gas-insulated switchgear. The main bus housing (A) is located at the top, with the vacuum interrupter housing (B) located below, and the current transformer housing (C) located beneath (B).

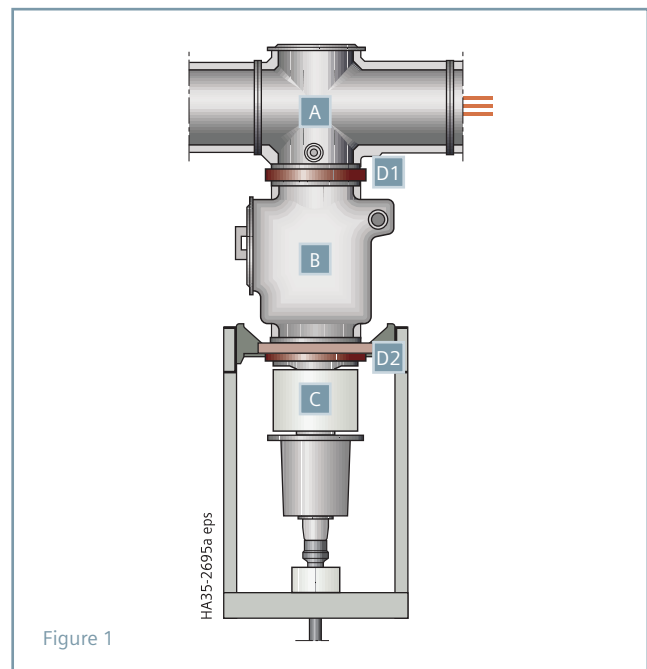

Figure 1

Item	Description
A	Main bus housing
B	Vacuum interrupter housing
C	Current transformer housing
D1	Insulator and gas barrier
D2	Insulator
E	Ground jumpers between main bus housings (A) and interrupter housings (B)
F	Ground connection
G	Main bus housing ground jumpers

The red areas between compartments indicate the epoxy insulators that electrically separate the compartments from each other.

Some of these are open to allow gas transfer between compartments (D2) and some of these (D1) are gas barriers for the isolation of the switchgear into appropriate gas zones.

The switchgear includes ground jumpers to connect the various housings together and to the switchgear ground bus. The photo in Figure 2 shows examples of ground jumpers (G) between adjacent housings in the bus bar area (A), and ground jumpers (E) between the bus bar housing and interrupter housings (B). However, the manner of grounding in the area of the CTs differs.

Figure 2

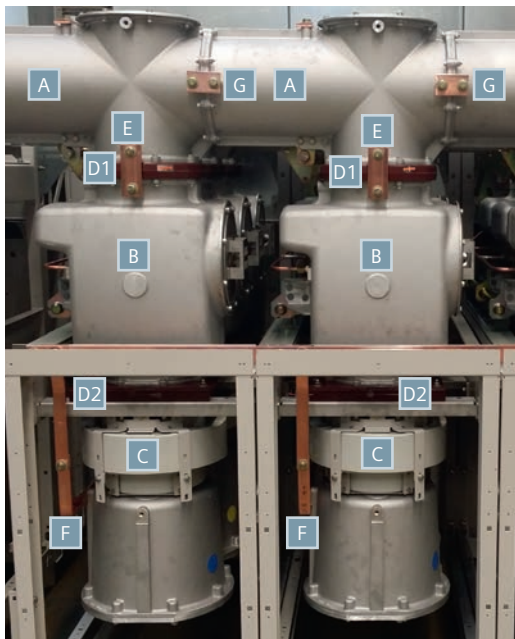

Returning to Figure 1, the epoxy insulator D2 does not have a ground jumper directly between the vacuum interrupter housing (B) and the CT housing (C). Thus, there is no current connection for ground return current through the aluminum housings. Instead, the connection is made from the bottom of the CT housing directly to the ground bus of the switchgear, allowing ground current to return to ground, but not allowing the ground return current to pass through the current transformer window.

This is illustrated in Figure 3. This shows the connection from the bottom side of the CT housing to the ground bus system of the switchgear.

The CTs are mounted in area C. The epoxy bushing between the CT housing (C) and the vacuum interrupter housing (B) does not have a grounding jumper across the epoxy bushing.

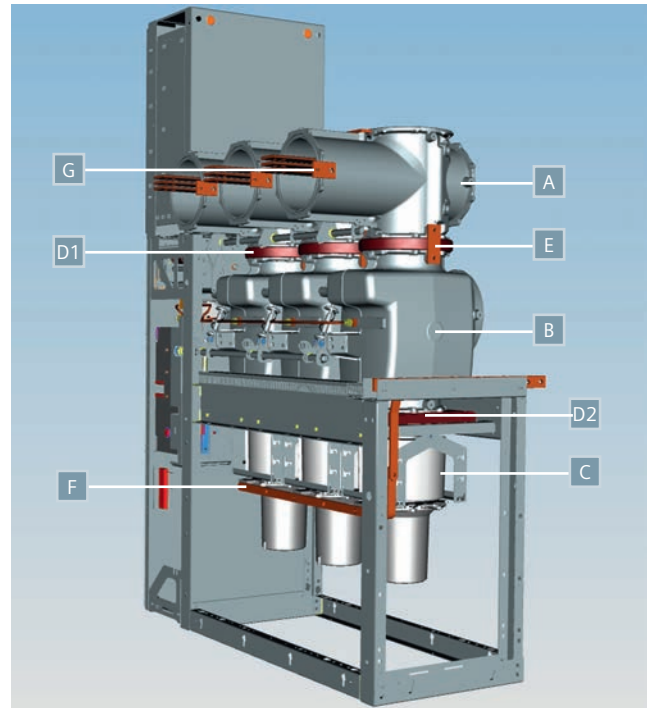

Figure 3

Instead, the ground connection (F) is made to the bottom of the CT housing, preventing the ground return current from passing directly through the CT window.

This illustrates the concept. All of our gas-insulated switchgear has grounding connections that are designed and configured such that the ground return current does not pass through the CT window, and hence, CTs properly sense phase current and ground current and relays can operate correctly.

Published by Siemens Industry, Inc. 2016.

Siemens Industry
7000 Siemens Road
Wendell, North Carolina 27591

For more information, please contact our Customer Support Center.
Phone: +1 (800) 347-6659

www.usa.siemens.com/techtopics

Article No. EMMS-T40041-00-4AUS
Printed in U.S.A.

© 2016 Siemens Industry, Inc.

Subject to changes and errors. The information given in this document only contains general descriptions and/or performance features which may not always specifically reflect those described, or which may undergo modification in the course of further development of the products. The requested performance features are binding only when they are expressly agreed upon in the concluded contract.