

## Heavy Duty Safety Switch

600A 600V, Type 12

Data Sheet

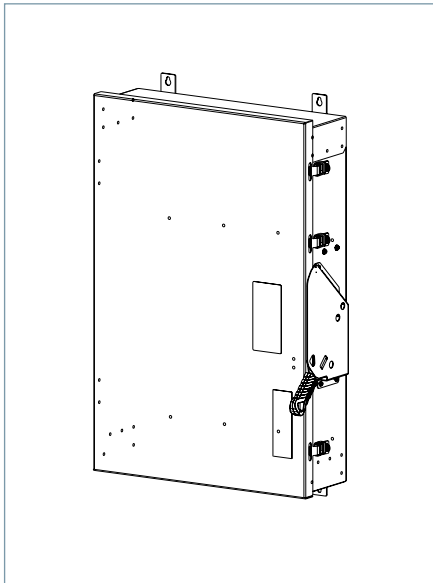

### Standards and Ratings

- UL listed under file #E4776
- CSA listed under file #154852
- Meets NEMA Standard KS-1 for enclosed switches
- Meets NEC wire bending space requirements
- Rated 10,000 AIC with class H fuses or 200,000 AIC with Class R, T or J fuses
- I2t rated (Amps<sup>2</sup> x Seconds = 12,000,000)
- 12X overload current rating exceeds 10X industry standard
- Suitable for use as service entrance equipment

### Features

- Quick-make and break switching action
- Visible blade design
- Highly visible ON/OFF indication
- Modular design allows quick and easy replacement of parts
- Defeatable dual cover interlock
- Compact one piece light weight construction enables easier installation
- Can utilize either one large or two small wires
- Spring loaded heat sink fuse clip
- One piece line and load base for consistent phase-to-phase alignment
- Extra ground lug on neutral
- Tangential knock out
- Lay in Lugs for easy wiring
- Window permits viewing of visible blade

# Product Specifications

## Heavy Duty 600V, Type 12

General Information		
Catalog Number	Description	Shipping Weight
HF366JA	Heavy Duty Fused 3 Pole 600V 600A Type 12, Industrial	98
HNF366JA	Heavy Duty Non-Fused 3 Pole 600V 600A Type 12, Industrial	77
HFC366NJA	CSA Heavy Duty Fused 3 Pole 600V 600A Neutral Type 12, Industrial	99.6
HFC366NJWA	CSA Heavy Duty Fused 3 Pole 600V 600A Neutral Type 12, Industrial, Viewing Window	99.6
HF366JWA	Heavy Duty Fused 3 Pole 600V 600A Type 12, Industrial, Viewing Window	98

Maximum Horsepower Ratings								
Catalog Number	1 Phase, 240V AC	3 Phase, 240V AC	1 Phase, 480V AC	3 Phase, 480V AC	1 Phase, 600V AC	3 Phase, 600V AC	250V DC	600V DC
HF366JA	—	200	—	400	—	500	50	50
HNF366JA	—	200	—	400	—	500	50	50
HFC366NJA	—	200	—	400	—	500	50	50
HFC366NJWA	—	200	—	400	—	500	50	50
HF366JWA	—	200	—	400	—	500	50	50

Accessories & Hub Kits	
Catalog Number	Description
HA161234	Aux. Switch (1NO - 1NC)
HA261234	Aux. Switch (2NO - 2NC)
HA361234	Low Voltage Aux. SW. (1NO - 1NC)
HN656A	Neutral
HN678A	200% Neutral
HG656A	Ground Lug
HG2656A	Isolated Ground
HR66A	R Fuse (600A)
TFAK65A	T Fuse (600A, 600V)
HJ66A	J Fuse (600A, 240/600V)
HCU66A	Copper Lug (600A, fused)
HNCU66A	Copper Lug (600A, nonfused)
HCM66A	Field Replacement Kit (600A, fused)
HNCM66A	Field Replacement Kit (600A, nonfused)
SSH250	2.50" Hub Kit
SSH300	3.00" Hub Kit
SSH350	3.50" Hub Kit
HCU656A	Copper Lug Kit <sup>Ⓢ</sup>
SSH400	4.00" Hub Kit

Replacement Parts	
Catalog Number	Description
HFB66A	Line Base 600A
HBB66A	Load Based Fused 600A
HL66A	Wire Grip AL Fused 600A
HM656A	Mechanism 400A-600A
HH656A	Handle/Handle Guard 400A-600A
Catalog Number + "DOOR"	Door

Mechanical Lug Wire Ranges	
Description	Wire Range
Line, Load, & Main Neutral (Fusible)	(1) 1/0 AWG - 600 kcmil or (2) 1/0 AWG - 500 kcmil
100% Neutral	(2) 1/0 - 600 Kcmil or (2) 6 - 300 Kcmil
200% Neutral	(4) 1/0 - 600 Kcmil or (2) 6 - 300 Kcmil

<sup>Ⓢ</sup> Purchase field replacement kit along with lugs. (See Speedfax pg. 4-20)

# Dimension Drawings

## Heavy Duty 600A 600V, Type 12 (Fusible)

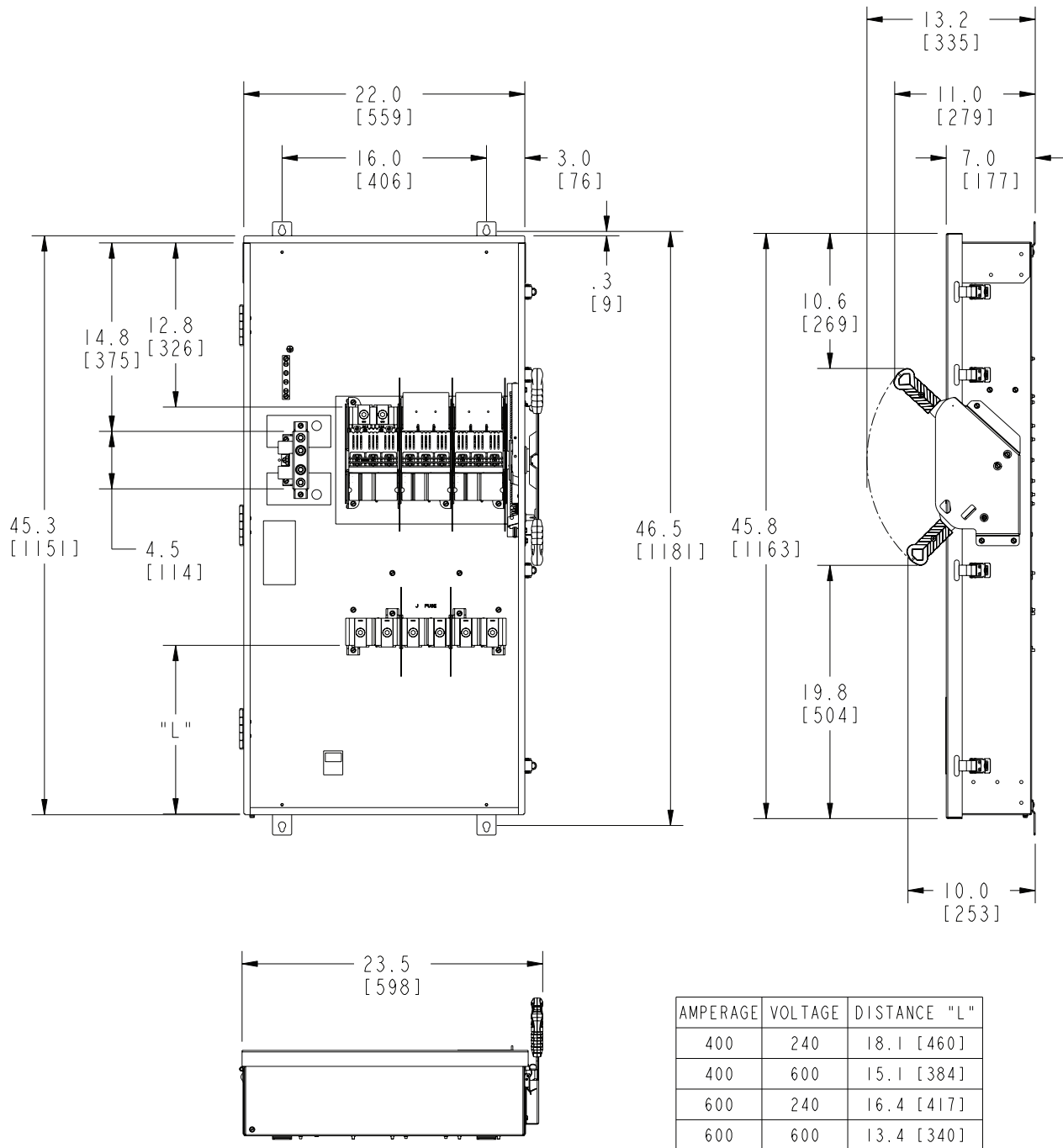

Dimensions shown in inches  
and millimeters [ ].  
Dimensions shown accurate to  $\pm 1/8$  inch.

Enclosure: Galvanized Steel  
.060 thick (16 gauge)  
Finish: ANSI Grey #61 Paint

# Heavy Duty 600A 600V, Type 12 (Non-Fusible)

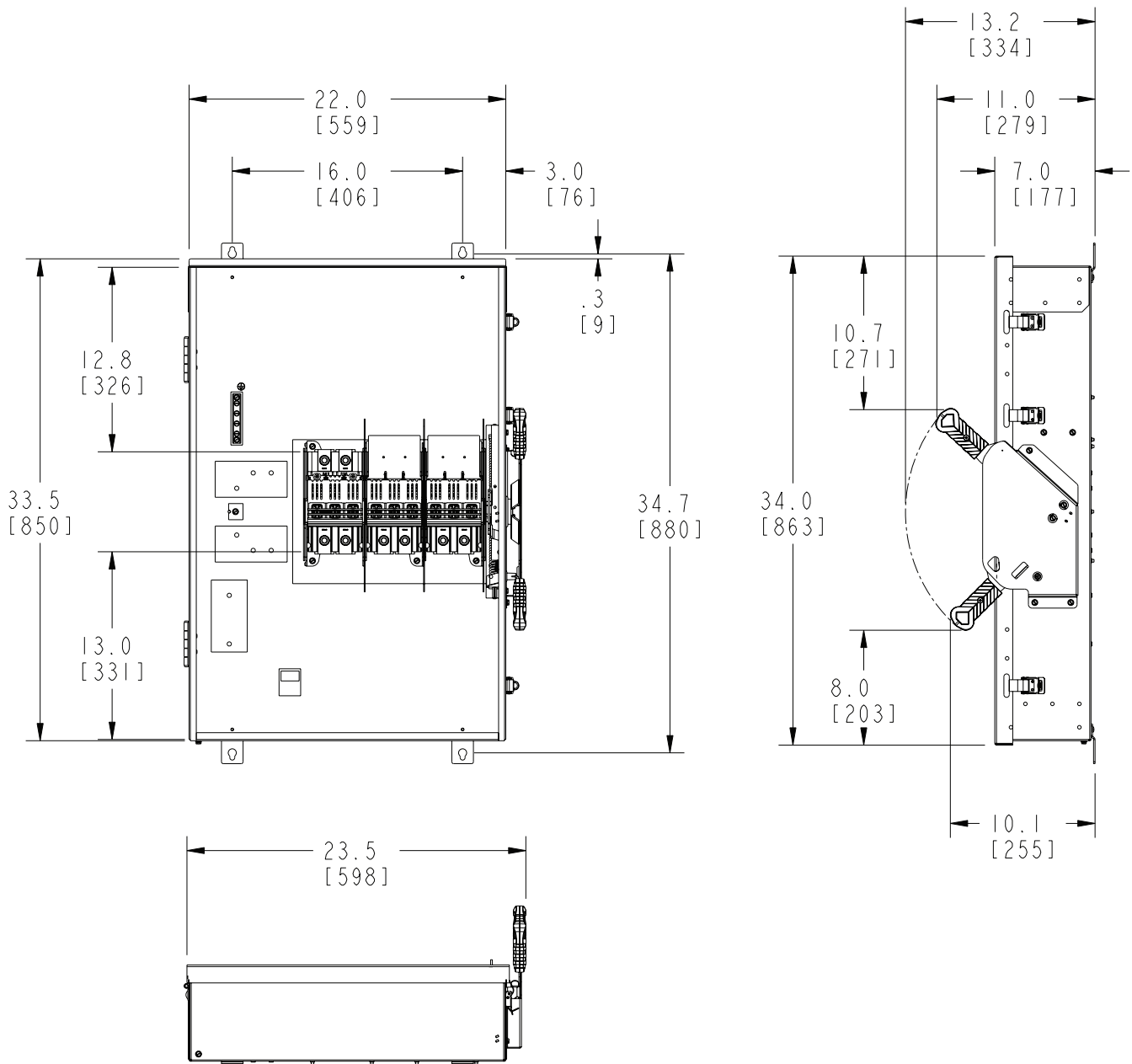

Dimensions shown in inches and millimeters [ ].  
Dimensions shown accurate to  $\pm 1/8$  inch.

Enclosure: Galvanized Steel  
.060 thick (16 gauge)  
Finish: ANSI Grey #61 Paint

Siemens Industry, Inc.  
5400 Triangle Parkway  
Norcross, GA 30092

1-800-241-4453  
info.us@siemens.com

Order No. | Printed in USA |  
© 2015, Siemens Industry, Inc.

[www.usa.siemens.com/switches](http://www.usa.siemens.com/switches)

The information provided in this flyer contains merely general descriptions or characteristics of performance which in case of actual use do not always apply as described or which may change as a result of further development of the products. An obligation to provide the respective characteristics shall only exist if expressly agreed in the terms of contract.

All product designations may be trademarks or product names of Siemens AG or supplier companies whose use by third parties for their own purposes could violate the rights of the owners.