

TechTopics No. 113

Preferred locations for current transformers

When designing a relay protection system, the concept of “zone of protection” in determining the preferred location of current transformers in the system is employed.

This concept involves decision about the region in an electrical system that a particular protective relay or combination of relays should protect.

To understand the concept, consider an example electrical system as shown below. The one-line only shows representative elements; a real system would likely have many more circuit breakers and circuits.

The dotted lines in the one-line diagram describe the various zones of protection in the circuit. The zone of protection is essentially the portion of the circuit within which you want the protection to sense a problem and provide protection. The goal of protection is to have each major element of a circuit protected by some form of relaying, and to provide backup protection should the primary protection not sense the fault. The protective zones usually include some degree of overlap to assure that every circuit element is included in at least one protective zone.

In the one-line diagram, the protective zones are:

- Zone 1 is a feeder zone, where the zone includes the feeder circuit breaker and the load circuit that the feeder circuit breaker serves.
- Zone 2 is a bus zone, in this example with two main circuit breakers and two feeder circuit breakers, and no tie circuit breaker. The protective zone extends to include the side of each circuit breaker opposite the main bus of the switchgear.
- Zone 3 is a zone for the interconnecting conductors that extend from the switchgear in zone 4 to that in zone 2. The zone extends to the side of each circuit breaker opposite the cables of the distribution line. This type of zone is typically associated with pilot wire relaying and long interconnecting circuits.

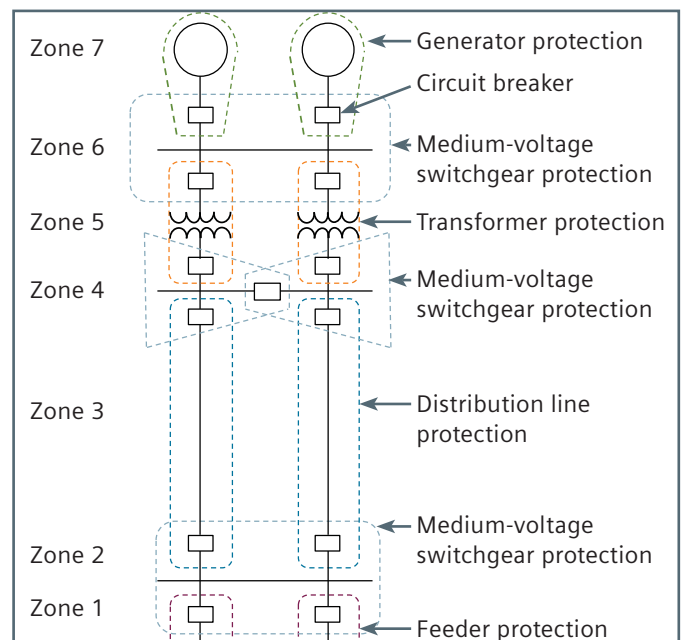

- Zone 4 is actually two zones, one for the left side of the switchgear and one for the right side of the switchgear. Each zone includes all circuit breakers connected to that bus (in the diagram, the main, tie and feeder circuit breakers, but in a real installation, there would be more feeder circuit breakers), and extends to side of the circuit breakers opposite the main bus.
- Zone 5 is a transformer zone, with protection extending to the side of the primary circuit breaker and the side of the secondary circuit breaker away from the transformer itself.
- Zone 6 is a bus zone, similar to zone 2, except in this case involving generator circuit breakers.
- Zone 7 is the generator zone, extending to include the generator, the connecting cables, and the generator circuit breaker.

To implement the protection zones, the preferred location of current transformers is on the side of the circuit breaker away from the zone. So, in zone 1, the preferred location for current transformers (CTs) is on the bus side of the feeder circuit breaker.

In zone 3, the CTs in the zone 4 switchgear are ideally located on the main bus side of that circuit breaker, and in the zone 2 switchgear, ideally on the main bus side of that switchgear.

In zone 4, the main breaker CTs are ideally on the transformer side of the main, the load feeder CTs ideally on the load cable side of the circuit, and the tie circuit breaker CTs on the side of the tie opposite the bus being protected.

Similar thoughts apply for the other zones.

In each situation, the concept is that the zone includes the circuit breakers at the extremes of the zone, so that any fault inside the zone will be sensed, and the appropriate circuit breaker tripped to eliminate the fault. Another fundamental concept of protective relaying is to cause the smallest possible part of the circuit to be interrupted for any given fault, instead of shutting down the entire system.

These examples illustrate that there are a number of applications in which the ideal location of CTs is on the main bus side of switchgear. The practical reality is that this is not always possible with any kind of equipment, be it gas-insulated switchgear (GIS) or air-insulated switchgear (AIS). Due to the nature of GIS, the issue arises more frequently than for AIS, so our discussion focuses on GIS equipment. For cases in which it is not possible to locate the CTs on the main bus side of the circuit breaker, a judgment must be made as to the degree of risk associated with not including some portion of the desired zone in the actual zone of protection.

Consider the example that is probably most common, that of a normal feeder circuit breaker in a GIS lineup. The desired location for the feeder CTs (zone 1 in our example one-line diagram) is on the main bus side of the feeder circuit breaker. However, in GIS switchgear, locating CTs on the main bus side is very difficult (i.e., expensive) and increases the switchgear height. The switchgear is designed for installation of CTs on the load side of the circuit breaker, as shown in the illustration of single-bus type 8DA GIS below. So judgment is required, assessment of the risk associated with the location of the CT on the load side of the circuit as compared to the ideal location on the main bus side of the circuit breaker. The difference in the two locations is that with the CT on the load side, the circuit breaker is not in the zone of protection.

What is the risk of not including the circuit breaker in the zone? Small, almost infinitesimal, but not zero. If the circuit breaker is not in the zone, the protection will not sense a fault in the circuit breaker. What is the practical significance? Siemens position is that this is of little concern in practical terms. If the fault is in the region between the practical load-side CT location and the ideal main bus-side CT location, the portion of the circuit that is not protected includes several feet of copper conductor and the vacuum interrupter, all inside the gas-insulated enclosure.

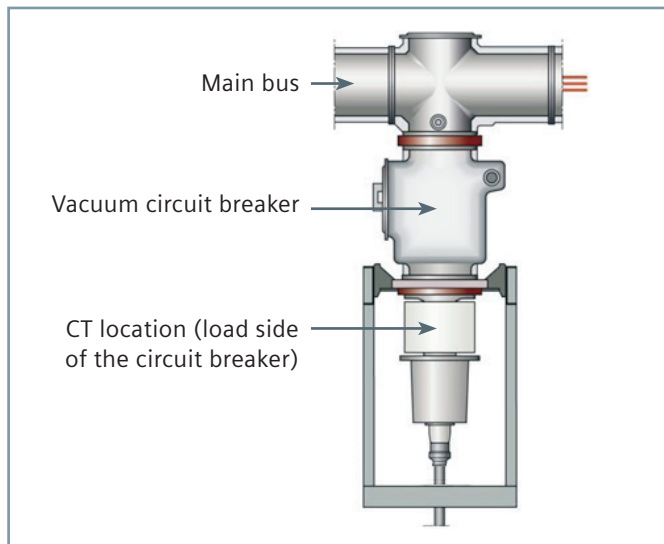

So, the portion of the circuit un-protected is extremely small. In addition, due to the nature of GIS switchgear, this region is probably the most highly secure region of the entire circuit as the GIS enclosure isolates this portion of the circuit from all environmental conditions. Further, if a fault does occur in this small, un-protected zone, it really does not matter if the fault is sensed or not, as the circuit breaker itself is failing. Since in this situation, the circuit breaker itself is at fault, opening of the circuit breaker would not remove the fault.

Therefore, there is no practical risk associated with locating the CTs on the load side of the circuit breaker instead of on the line (bus) side of the circuit breaker.

TechTopics are published for informational purposes only. Siemens makes no guaranty of accuracy or applicability to any specific customer projects or applications, and assumes no responsibility for the readers' use of this information. Siemens recommends that anyone seeking to use this information in field operations consult with or verify its applicability through an independent qualified professional.

The information provided in this document contains merely general descriptions or characteristics of performance which in case of actual use do not always apply as described or which may change as a result of further development of the products. An obligation to provide the respective characteristics shall only exist if expressly agreed in the terms of contract.

All product designations may be trademarks or product names of Siemens AG or supplier companies whose use by third parties for their own purposes could violate the rights of the owners.

Siemens Industry, Inc.
7000 Siemens Road
Wendell, NC 27591

Subject to change without prior notice.
Order No.: IC1000-F320-A270-X-4A00
All rights reserved.
© 2015 Siemens Industry, Inc.

For more information, contact: +1 (800) 347-6659

www.usa.siemens.com/techttopics