

HAZARDOUS VOLTAGE

- This equipment must be installed and serviced only by qualified electrical personnel.
- Turn off all power supplying this equipment before working on or inside equipment.
- Always use a properly rated voltage sensing device to confirm power is off.
- Replace all devices, doors, and covers before turning on power to this equipment.

Failure to follow these instructions could cause death or serious injury.

TENSION DANGEREUSE

- L'installation et l'entretien de cet appareil ne doivent être effectués que par du personnel qualifié.
- Coupez l'alimentation de cet appareil avant d'y travailler.
- Utilisez toujours un dispositif de détection de tension à valeur nominale approprié pour confirmer que toute alimentation est coupée.
- Remplacez tous les dispositifs, les portes et les couvercles avant de mettre cet appareil sous tension.

Si ces précautions ne sont pas respectées, cela peut entraîner la mort ou des blessures graves.

TENSION PELIGROSA

- Solamente el personal de mantenimiento eléctrico especializado deberá instalar y prestar servicios de mantenimiento a este equipo.
- Desenergice el equipo antes de realizar cualquier trabajo en él.
- Siempre utilice un dispositivo detector de tensión adecuado para confirmar la desenergización del equipo.
- Vuelva a colocar todos los dispositivos, las puertas y las cubiertas antes de energizar este equipo.

El incumplimiento de estas precauciones podrá causar la muerte o lesiones serias.

CFS361JL / CFS362JL

Dual dimensions in/mm
Double dimensions in/mm
Doble dimensiones in/mm

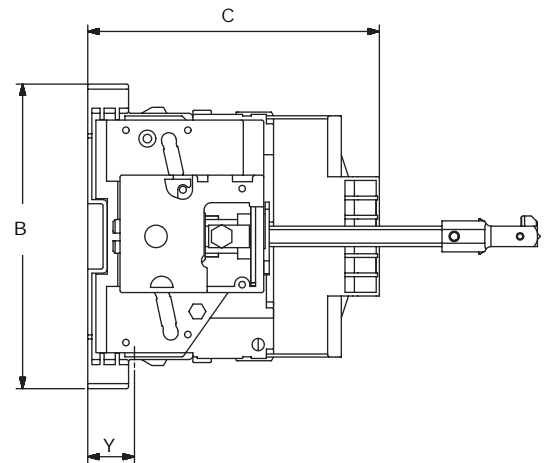
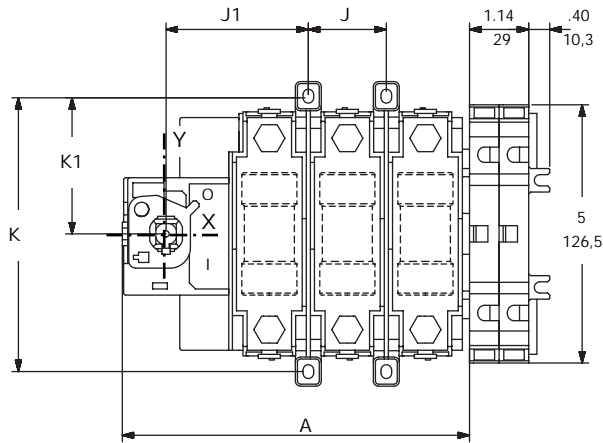

CFS363JL

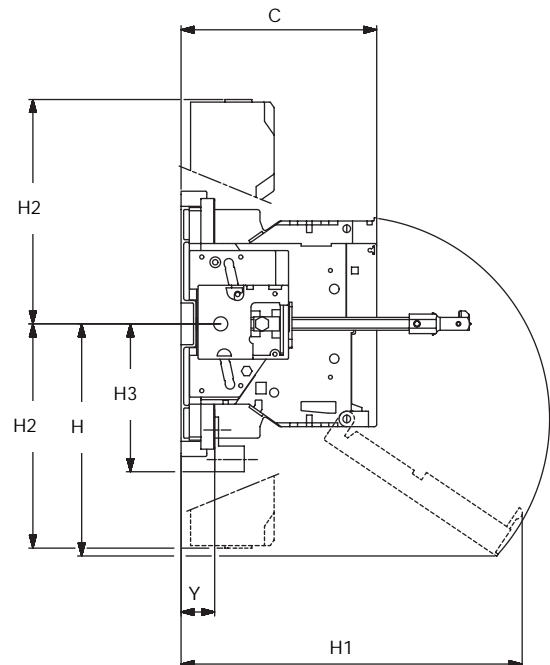
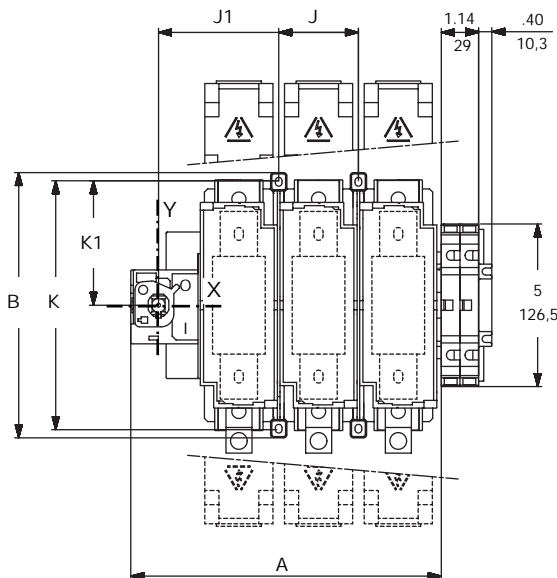

	A		B		C		H		H1		H2		H3		J		J1		K		K1		Y	
	in	mm	in	mm	in	mm	in	mm	in	mm	in	mm	in	mm	in	mm	in	mm	in	mm	in	mm	in	mm
CFS361JL	6.72	171	5.87	149	5.62	143	/	/	/	/	/	/	/	/	1.5	38	2.75	69,5	5.31	135	2.63	66.5	0.95	24,5
CFS362JL	6.72	171	5.87	149	5.62	143	/	/	/	/	/	/	/	/	1.5	38	2.75	69,5	5.31	135	2.63	66.5	0.95	24,5
CFS363JL	8.26	210	7.19	182,5	5.63	143	4.06	103	10.24	260	5.27	134	3.66	93	2.05	52	3.28	83,5	6.61	168	3.28	83.5	1	26

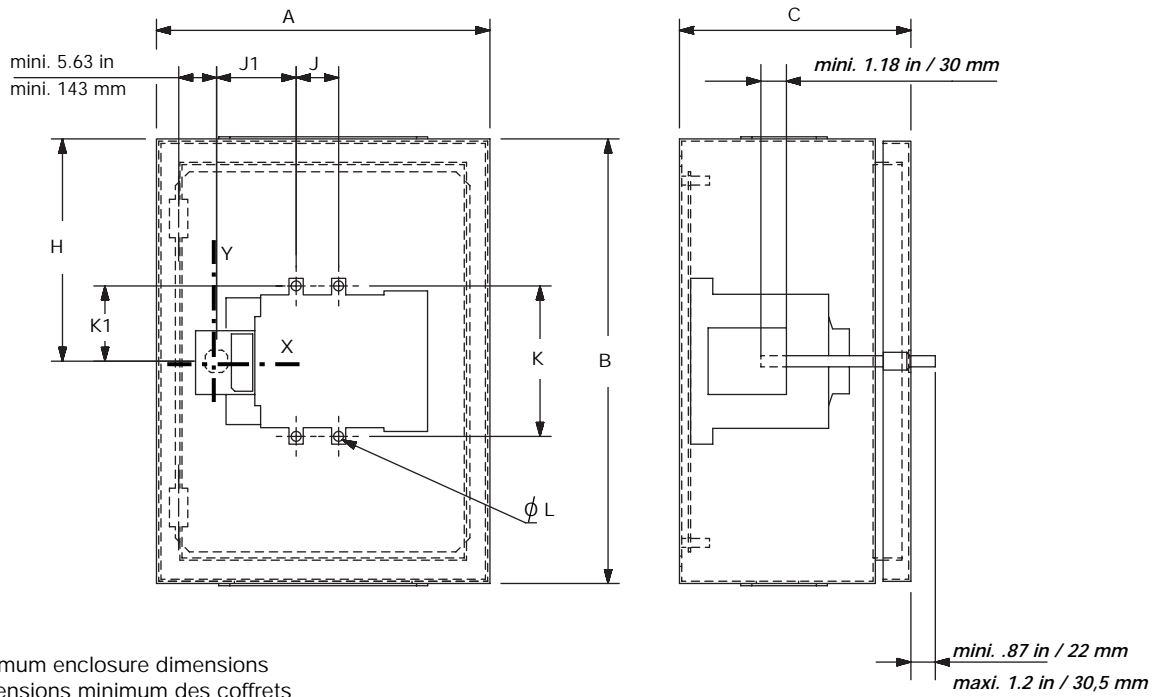

	A		B		C		H		J		J1		K		K1		ØL	
	in	mm	in	mm	in	mm	in	mm	in	mm	in	mm	in	mm	in	mm	in	mm
CFS361JL	10	254	10	254	6	153	3	76	1.5	38	2.75	69,5	5.31	135	2.63	66,5	0.20	5
CFS362JL	10	254	10	254	6	153	4.5	114	1.5	38	2.75	69,5	5.31	135	2.63	66,5	0.20	5
CFS363JL	20	508	24	610	9	229	7.5	190	2.05	52	3.28	83,5	6.61	168	3.28	83,5	0.20	5

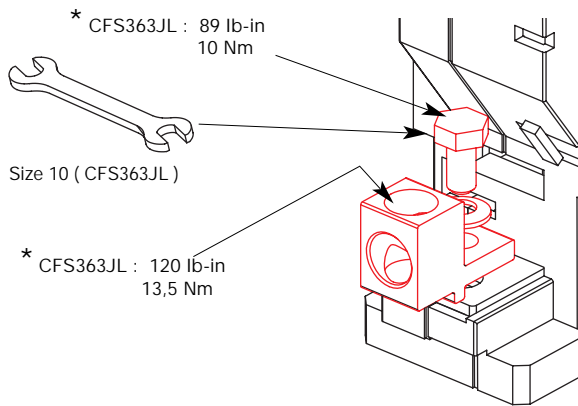

CFSL100 (CFS363JL)

Cable size and torque
 Section de cable et couple de serrage
 Sección de cables y par de apriete

	Size / Section Sección (AWG)		Torque Couple Par de apriete	
	mini.	maxi.	lb.in	Nm
CFS361JL	# 10	# 3	58	6,5
CFS362JL	# 10	# 3	58	6,5
* CFS363JL	# 14	2 / 0	120	13,5

CFSTS100

