

## Shield Kit

<b>Cat. No.</b>	<b>For Use with Switch Amperages</b>
<b>HSK61SSW</b>	30 Amp Heavy Duty / 60 Amp General Duty
<b>HSK62SSW</b>	60 Amp Heavy Duty
<b>HSK63SSW</b>	100 Amp General / Heavy Duty
<b>HSK64SSW</b>	200 Amp General / Heavy Duty

**For Use With: 30-200 Amp Type VBII Fusible Enclosed Switches  
Para Usar Con Caja Base: 30-200 Amp Type VBII Fusible Enclosed Switches**

### Installation Instructions / Instructivo de Instalación

	 <b>Danger</b>	 <b>Peligro</b>	 <b>Danger</b>
	<b>Hazardous Voltage</b> Will cause death or serious injury Turn off and lock out all power supplying this device before working on this device. Replace all covers and close the enclosure door before power supplying this device is turned on.	<b>Tensión peligrosa.</b> Puede causar la muerte o lesiones graves. Desenergice totalmente antes de instalar o darle servicio. Reemplace todas las barreras y cubiertas antes de energizar el interruptor.	<b>Tension dangereuse.</b> Danger de mort ou risque de blessures graves. Couper l'alimentation de l'appareil et barrer avant de travailler. Remplacez tous les couverts avant que l'alimentation de pouvoir soit alimenté.

Use only with Siemens certified Components.  
 Utilizar únicamente con componentes certificados por Siemens.  
 A utiliser uniquement avec les composants certifiés Siemens.

For use with Enclosure Types:

1, 3R, 4X & 12

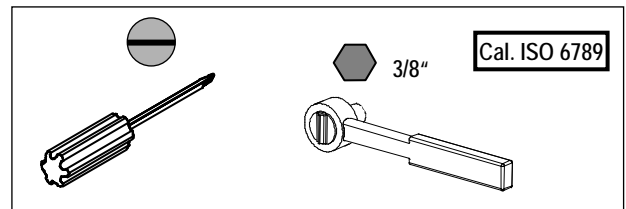

NOTE - These instructions do not purport to cover all details or variations in equipment, or to provide for every possible contingency to be met in connection with installation, operation or maintenance.

Should further information be desired or should particular problems arise, which are not covered sufficiently for the purchaser's purposes, the matter should be referred to the local Siemens sales office. The contents of this instruction manual shall not become part of or modify any prior or existing agreement, commitment or relationship. The sales contract contains the entire obligation of Siemens. The warranty contained in the contract between the parties is the sole warranty of Siemens. Any statements contained herein do not create new warranties or modify the existing warranty.

Trademarks - Unless otherwise noted, all names identified by ® are registered trademarks of Siemens AG or Siemens Industry, Inc. The remaining trademarks in this publication may be trademarks whose use by third parties for their own purposes could violate the rights of the owner.

## Unpacking Instructions

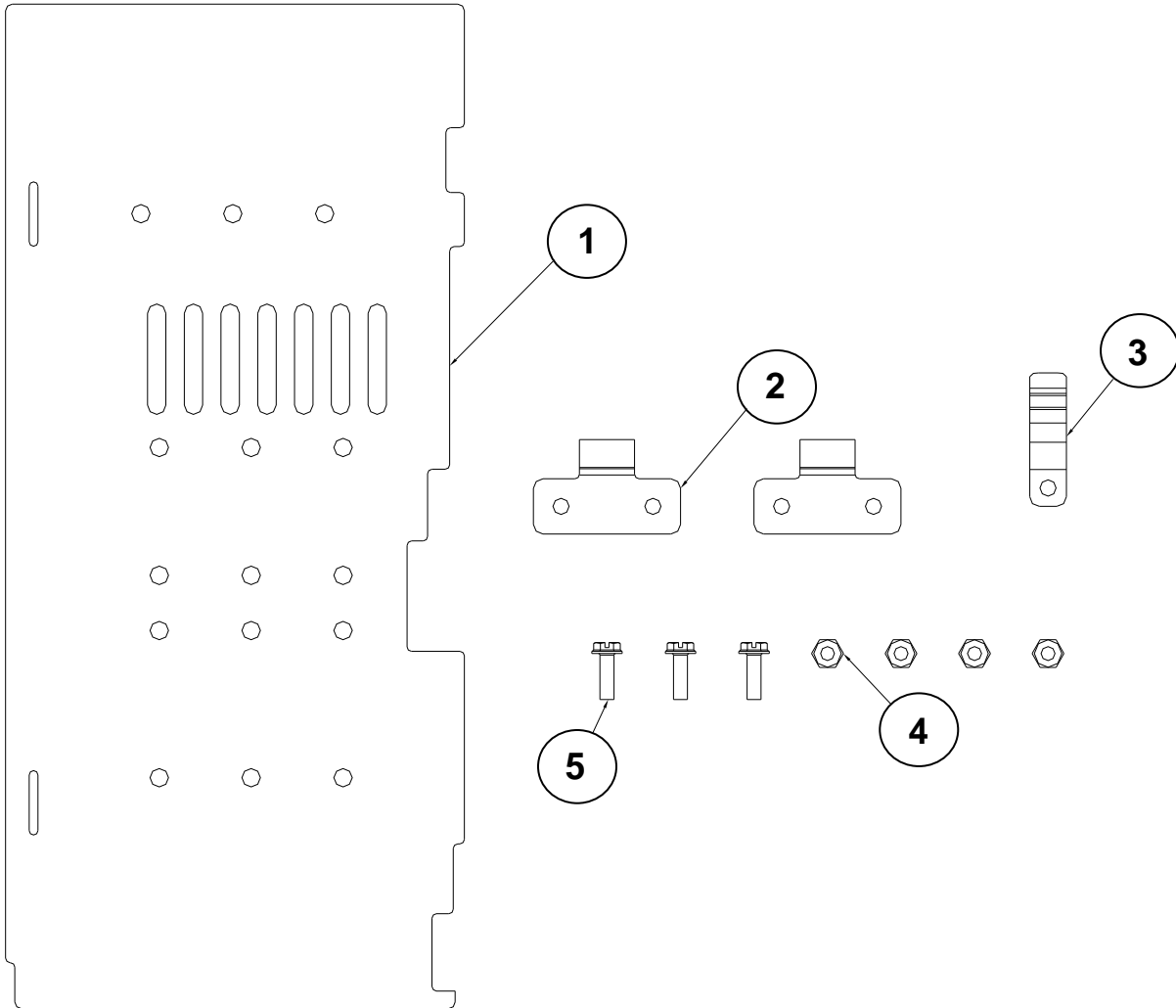

**1. Shield**

**2. Hinge**

**3. Latch**

**4. #10-32 SS Nut**

**5. #10-32 x .625 inch Screw**

	<p><b>⚠ Danger</b>  <b>Hazardous Voltage</b>  <b>Will cause death or serious injury</b></p>	<p><b>⚠ Peligro</b>  <b>Tensión peligrosa.</b>  <b>Puede causar la muerte o lesiones graves.</b></p>	<p><b>⚠ Danger</b>  <b>Tension dangereuse.</b>  <b>Danger de mort ou risque de blessures graves.</b></p>
	<p>Turn off and lock out all power supplying this device before working on this device.          Replace all covers and close the enclosure door before power supplying this device is turned on.</p>	<p>Desenergice totalmente antes de instalar o darle servicio.          Reemplace todas las barreras y cubiertas antes de energizar el interruptor.</p>	<p>Couper l'alimentation de l'appareil et barrer avant de travailler.          Remplacez tous les couverts avant que l'approvisionnement de pouvoir soit alimenté.</p>

**Prepare device for Shield Kit installation.**

**Step 1 Turn OFF and lock out all power supplying this device before working on this device.**

**Step 2 Turn OFF Switch.**

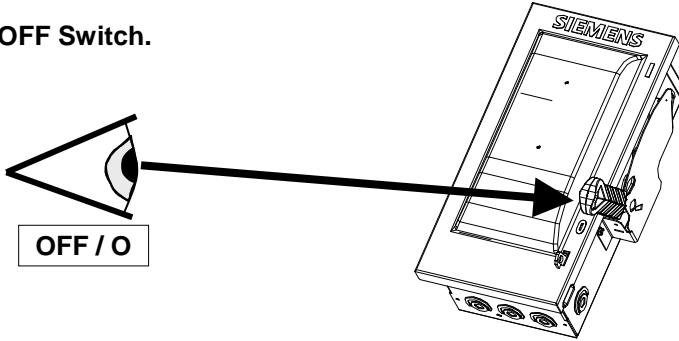

**Step 3 For Type 4X enclosures, skip to Step 8.**

**Step 4 For Type 1, 3R, & 12 enclosures, remove bottom screw from the upper and lower hinge.**

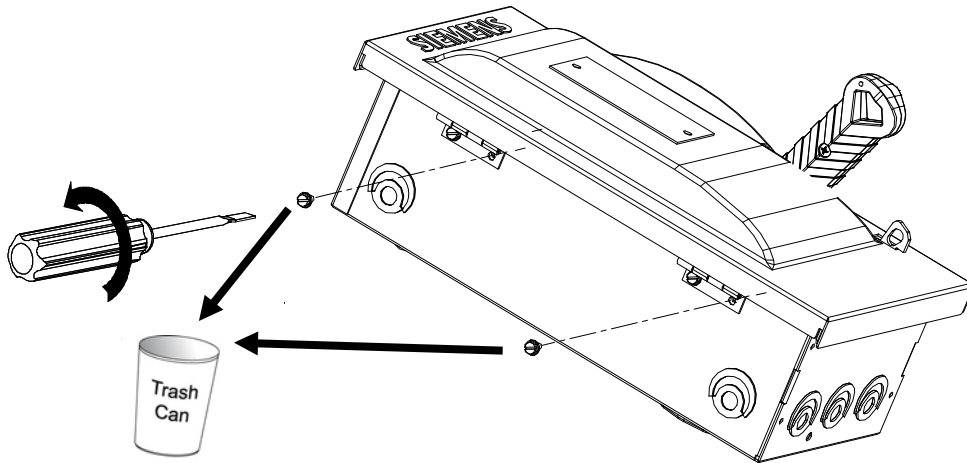

**Step 5 Install screws, item 5, into the upper and lower hinge.**

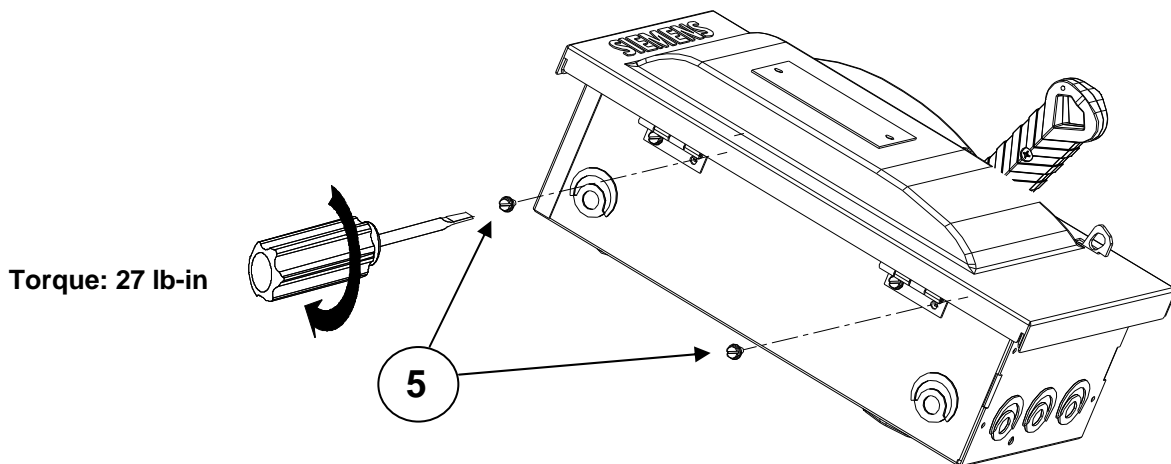

**Torque: 27 lb-in**

**Step 6 Remove handle guard screw.**

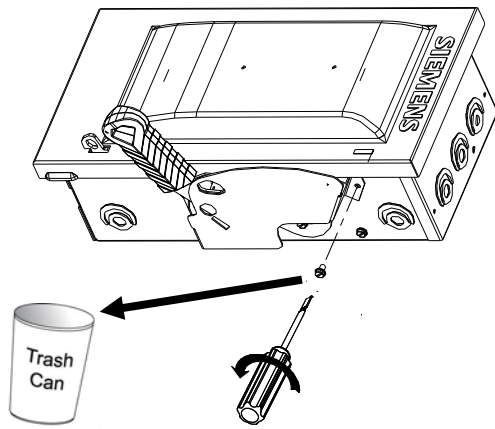

**Step 7 Install screw, item 5, into the handle guard.**

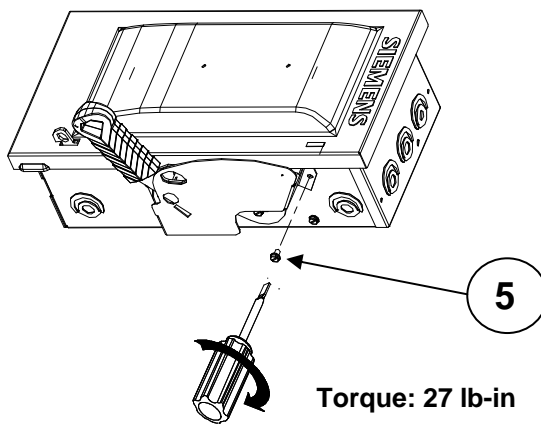

**Step 8 Install latch, item 3.**

**CAUTION**  
Removal of nut and sealing washer on Type 4X enclosures will result in egress of water causing equipment damage. Do not remove nut and sealing washer.

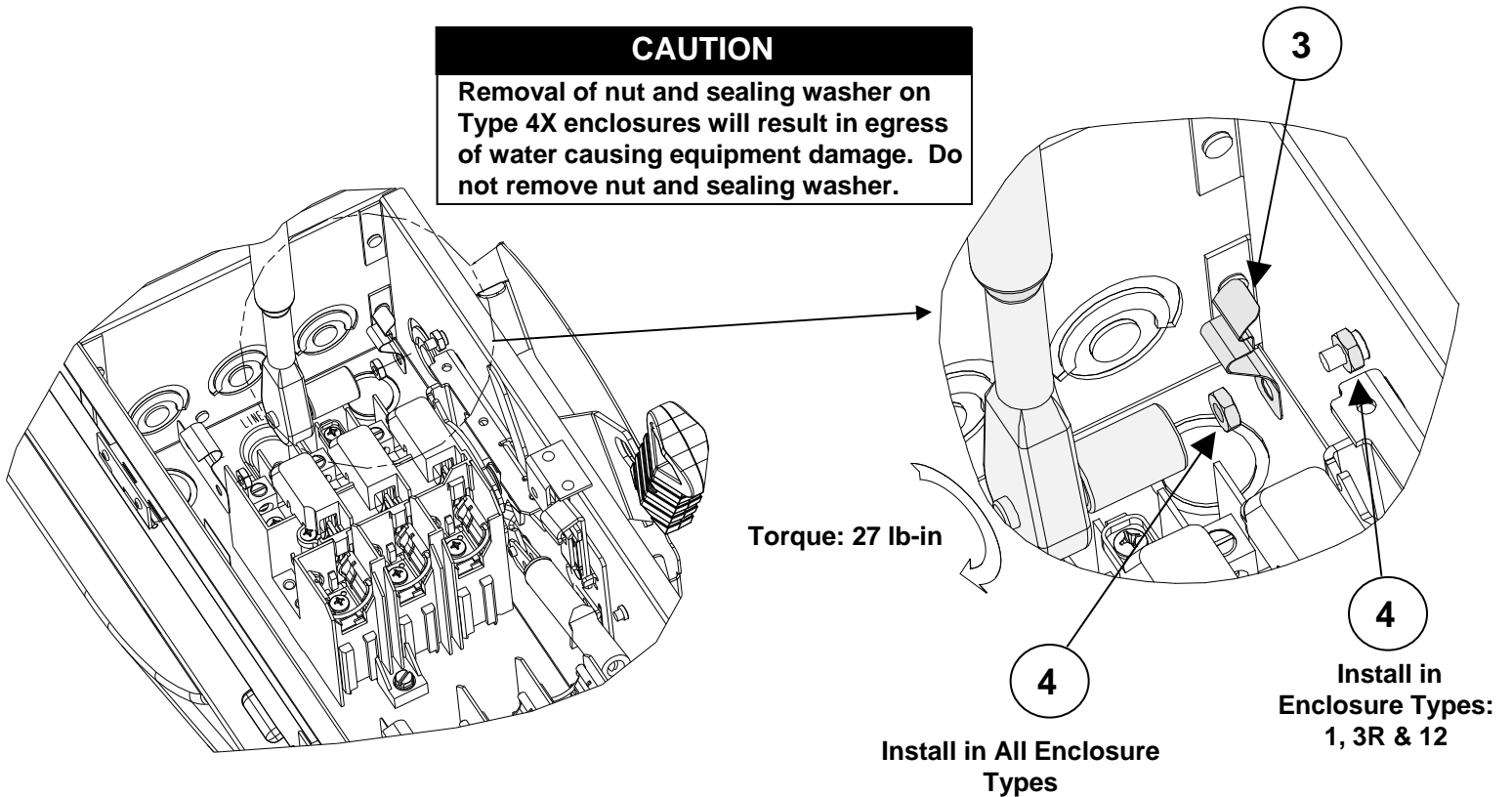

	<p><b>! Danger</b></p>	<p><b>! Peligro</b></p>	<p><b>! Danger</b></p>
	<p><b>Hazardous Voltage</b> Will cause death or serious injury</p> <p>Turn off and lock out all power supplying this device before working on this device. Replace all covers and close the enclosure door before power supplying this device is turned on.</p>	<p><b>Tensión peligrosa.</b> Puede causar la muerte o lesiones graves.</p> <p>Desenergice totalmente antes de instalar o darle servicio. Reemplace todas las barreras y cubiertas antes de energizar el interruptor.</p>	<p><b>Tension dangereuse.</b> Danger de mort ou risque de blessures graves.</p> <p>Couper l'alimentation de l'appareil et barrer avant de travailler. Remplacez tous les couverts avant que l'approvisionnement de pouvoir soit alimenté.</p>

**Step 9** For switches without auxiliary switch kits HA#61234 installed and all 200 Amp switches, proceed to Step 11.

**Step 10** For 30-100 Amp switches with auxiliary kits HA#61234 installed, cutout shield as shown below.

(Only required on 30-100 amp switches when auxiliary switch kit is installed .)

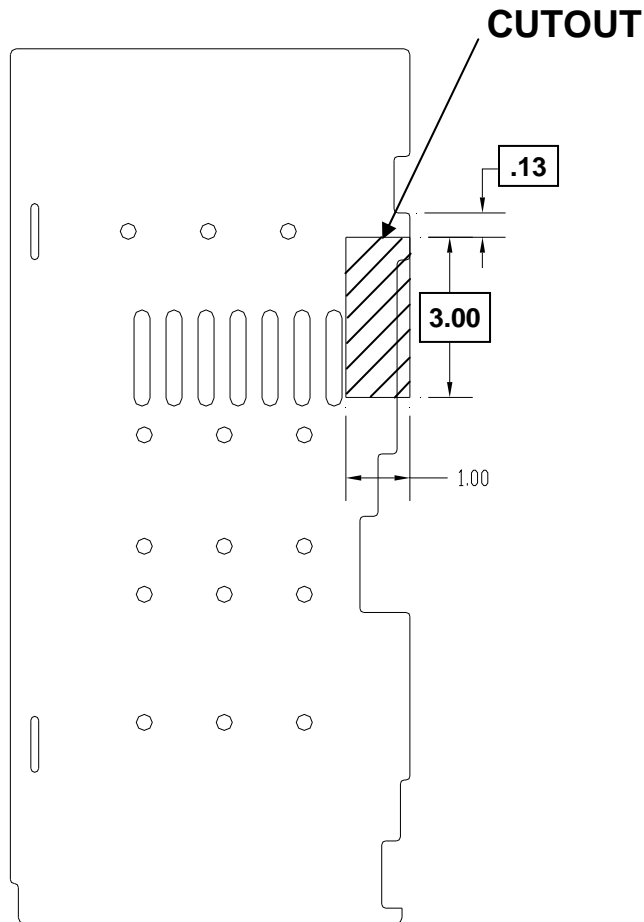

	<p><b>⚠ Danger</b></p>	<p><b>⚠ Peligro</b></p>	<p><b>⚠ Danger</b></p>
	<p><b>Hazardous Voltage</b> Will cause death or serious injury</p> <p>Turn off and lock out all power supplying this device before working on this device. Replace all covers and close the enclosure door before power supplying this device is turned on.</p>	<p><b>Tensión peligrosa.</b> Puede causar la muerte o lesiones graves.</p> <p>Desenergice totalmente antes de instalar o darle servicio. Reemplace todas las barreras y cubiertas antes de energizar el interruptor.</p>	<p><b>Tension dangereuse.</b> Danger de mort ou risque de blessures graves.</p> <p>Couper l'alimentation de l'appareil et barrer avant de travailler. Remplacez tous les couverts avant que l'approvisionnement de pouvoir soit alimenté.</p>

**Step 11** Insert 2 hinges, item 2, into shield, item 1. Install hinges, item 2, secure with nuts, item 4.

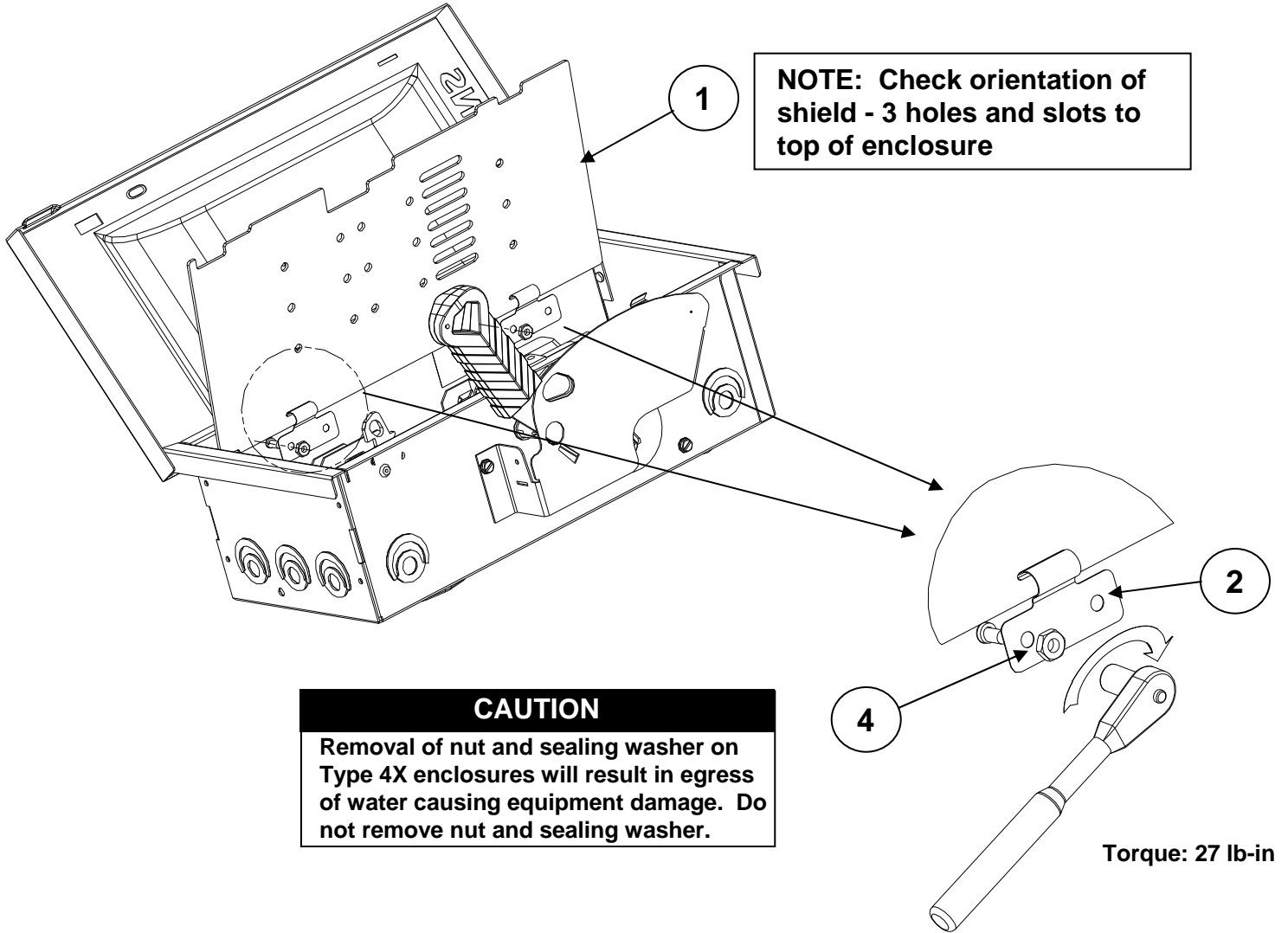

**Step 12** Replace all covers and close the enclosure door before power supplying this device is turned on.