

Features

- TYPE 3R OUTDOOR ENCLOSURE
- MAIN BUS RATING: 1200A MAX.
- 120/240 Volts~, 1 Phase, 3 Wire
208Y/120 Volts~, 1 Phase, 3 Wire
(from 3 Phase, 4 Wire network)

Catalog Numbers

Catalog No.	Phase	Amperage Rating, Max.	Maximum Interrupting Rating
WXB1200N	1	200	65,000
WXB1200NU	1	200	100,000
WXB1250N	1	250	65,000
WXB1250NU	1	250	100,000
WXB1300N	1	300	65,000
WXB1300NU	1	300	100,000
WXB1350N	1	350	65,000
WXB1350NU	1	350	100,000
WXB1400N	1	400	65,000
WXB1400NU	1	400	100,000

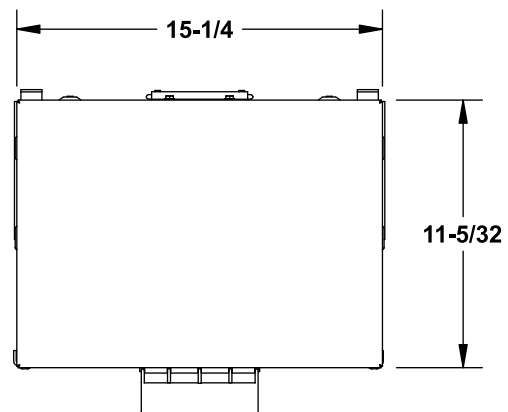

Accessories

Ground Bar Kit: Catalog No. ECGB10

Terminal	Wire Size	Torque
Equipment	#10 - #14 CU	20 lb-in
Ground Bar	#10 - #12 AL	20 lb-in
	#8 CU/AL	25 lb-in
	#6 - #4 CU/AL	35 lb-in

USE ONLY NON-INTERCHANGEABLE TRIP BREAKER TYPES

Breaker Type	Rating
JXD2-A	65k AIC
JXD6-A, HJXD6-A	100k AIC

Accessory Description	Catalog No.
Breaker Cover Repl.	ECMMBCM
Cover Screws.	ECMFCS
Loose Parts Kit.	ECMFPK
Mounting Tabs (2)	ECMFTAB
QuickRoll Wheel Clip.	ECMFWLCLIP
End Closure Plate	WMEP
Mounting Clip.	MMCLIP
Wall Mounting Rail (60")	MMZR60
Mounting Rail.	MMRAIL

Additional Modules

FOR USE WITH:		
Module Description	Siemens Series#	Murray Series#
Main Breakers	(W)MC, WB, WEB	DB W
Switches	WMP, WMS, WS, WES	DPT W, DT W
Tap/Terminal Boxes	WMTB, WTB, WET	DTB_W
Pull Boxes	WMMB, WT_PU	DPB_W
Meter Module	WMM, WxMM, WMT, WML, WMK	DG_W, DC_W, DL_W
Extension Box	WMEX, WSP	DS
Bussed Elbow	BE	DL

Connect Modules Using:	Catalog Number / Torque
QuickConnect	QC1 (1ph) 400-440 lb-in (35-36 ft.-lb.) Torque
Single Bolt Joint	SBJ1 (1ph) 400-480 lb-in (35-40 ft.-lb.) Torque

Schematic

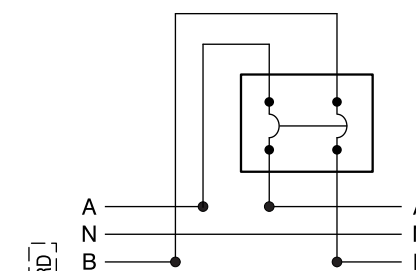

When this module is used as a Service Disconnect, apply "Service Disconnect" label near the breaker handle cover. In all other applications, apply the "Feeder Breaker" label near the breaker handle cover.

View Shown with Cover Removed

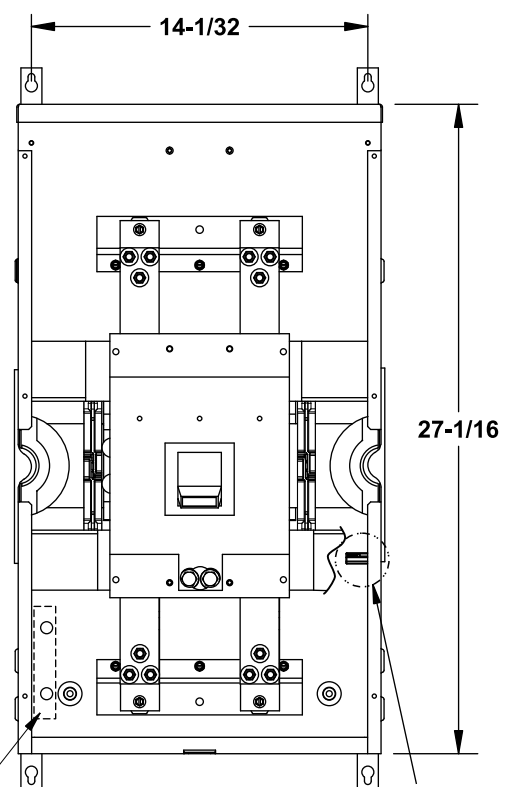

GROUND BAR PROVISION

SPRING-LOADED STUDS (SEE DETAIL)

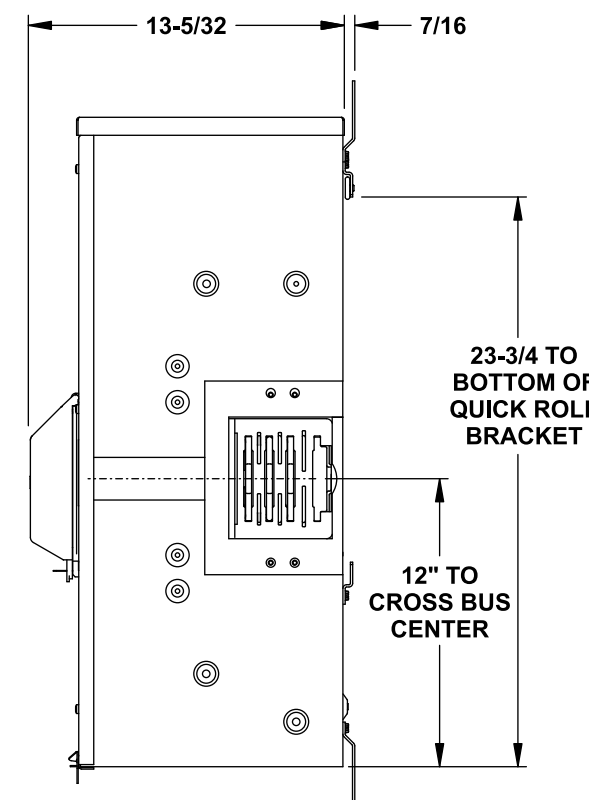

23-3/4 TO BOTTOM OF QUICK ROLL BRACKET

12" TO CROSS BUS CENTER

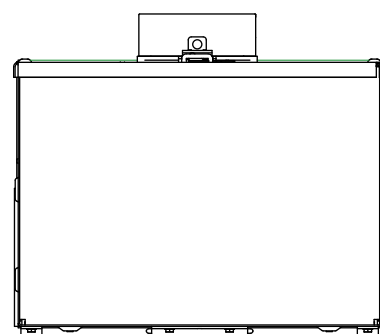

#10-32 x 7/8 SCREWS ENCLOSURE WALL

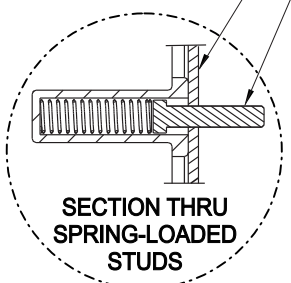

SECTION THRU SPRING-LOADED STUDS

© 2012 Copyright Siemens Industry, Inc.

SIEMENS
Siemens Industry, Inc.

PowerMod™ Cross Bus Main

Catalog Numbers:
1 Phase, 200-400A, 65k-100kAIC Modules

Size B Dwg. No. **WXB1200N-WXB1400NU**

Dwn KAM Date 11/2/12 DO NOT SCALE DRAWING SHEET 1 OF 1