

Heavy Duty Safety Switch with Viewing Window

Type VBII, 600 Amp, Type 12 (Industrial) ¹

Standards and Ratings

- UL Listed under file #E4776
- Meets UL98 for switches and UL 50 for enclosures
- Meets NEMA Standard KS-1 for enclosed switches
- Meets NEC wire bending space requirements
- Rated 10,000 AIC with Class H fuses or 200,000 with Class R, J and T fuses
- I²t rated (Amps² x Seconds = 12,000,000)
- 12X overload current rating exceeds 10X industry standard
- Suitable for use as service entrance equipment

Features

- Quick-make and break switching action
- Visible blade design
- Highly visible ON/OFF indication
- Window permits viewing of visible blades
- Modular design allows quick and easy replacement of parts
- Front removable lugs which can easily be converted to copper body or compression type lugs
- Defeatable dual cover interlock

General Information

Catalog Number	Volts	Description	Shipping Weight (lbs.)
HF366JW	600	3 Pole, 3 Wire, Fusible	168

Horsepower Ratings ^{2 3} - 600 Volts

Catalog Number	3 Phase, 480V AC		3 Phase, 600V AC		600V DC
	Std	Max	Std	Max	
HF366JW ⁴	150	400	200	500	—

Accessories

Catalog Number	Description
HA165678	One Normally Open and Closed Auxiliary Switches
HA265678	Two Normally Open and Closed Auxiliary Switches
HA365678	Low Voltage Auxiliary Switch
HG656	Equipment Ground Lug Kit (Factory installed)
HG2656	Isolated Equipment Ground Lug Kit
HN656	Neutral Kit
HN678	200% Neutral Kit
HR656	Class R Fuse Clip Kit (3 fuse clips per kit)
HLC65678	Copper Lug Kit (1 lug per kit)
HCL65678	Compression Lug Mounting Kit (1 kit/pole required allows (2) lugs/Ø)

¹ Also rated 3R/3S for outdoor use.

² Dual horsepower ratings: Std - applies when non-time delay fuses are installed.
Max - applies when time-delay fuses are installed.

³ Horsepower ratings listed also apply to Design E motors through 150HP at 240V, 300HP at 480V and 350HP at 600V with no derating.

⁴ Rated 50HP on 250V DC systems.

Product Specification Sheet HD600.9

Answers for industry.

SIEMENS

Product Specification Sheet #HD600.9 (page 2 of 3)

Replacement Parts

Catalog Number	Description
HFB66 ^{1 2}	Fusible Line Side Replacement Base
HBB656 ^{1 2}	Fusible Load Side Replacement Base
HH65678S	Replacement Handle/Handle Guard
HL65678 ²	Replacement Lug (1 lug per kit)
HM66	Replacement Mechanism
³	Replacement Door

Mechanical Lug Wire Ranges (75°C, Cu/Al)

Description	Wire Range
Line, Load	(2) 1/0 AWG - 750 Kcmil or
Neutral	(4) 1/0 AWG - 250 Kcmil
Ground	(2) #6 AWG - 250 Kcmil
200% Neutral	(4) #1/0 AWG - 600 Kcmil
200% Ground	(4) #6 AWG - 300 Kcmil

Compression Lugs⁴

Wire Size	Burndy		Thomas-Betts		Ilsco	
	CU Only	CU/AL	CU Only	CU/AL	CU Only	CU/AL
2/0	YA26-N	YA26-A1	54160 54951BE			IACL-2/0 ACN-2/0
3/0	YA27-L Box YA27	YA27A3	54165-TB 54965BE		CRB-3/0 CRB-3/OL	IACL-3/0 ACN-3/0
4/0	YA28-L Box YA28	YA28A3	54170 54970BE	60150	CRB-4/0 CRB-4/OL	IACL-4/0 ACN-4/0
250 Kcmil	YA29-L Box YA29	YA29A1	54113 54913BE	61156 60156	CRA-250 CRA-250L	IACL-250 ACL-250
300 Kcmil	YA30-L YA30	YA30A1	54114 54914BE	61162 60162	CRA-300 CRA-300L	IACL-300 ACL-300
350 Kcmil	YA31-L YA31	YA31A1	54915BE	61165 60165	CRA-350 CRA-350L	IACL-350 ACL-350
400 Kcmil	YA32-N		54116 54916BE			
500 Kcmil	YA34-L6 YA34-N			61171		IACL-500

¹ Each Line and Load Replacement Base contains one pole.

² Lugs are not provided on Line and Load Replacement Base Assemblies. Order Lug Kit.

³ Place "DOOR" at the end of the switch catalog number.

⁴ If compression lugs are used, order compression lug kit HCL65678.

Product Specification Sheet #HD600.9 (page 3 of 3)

Dimension Drawing

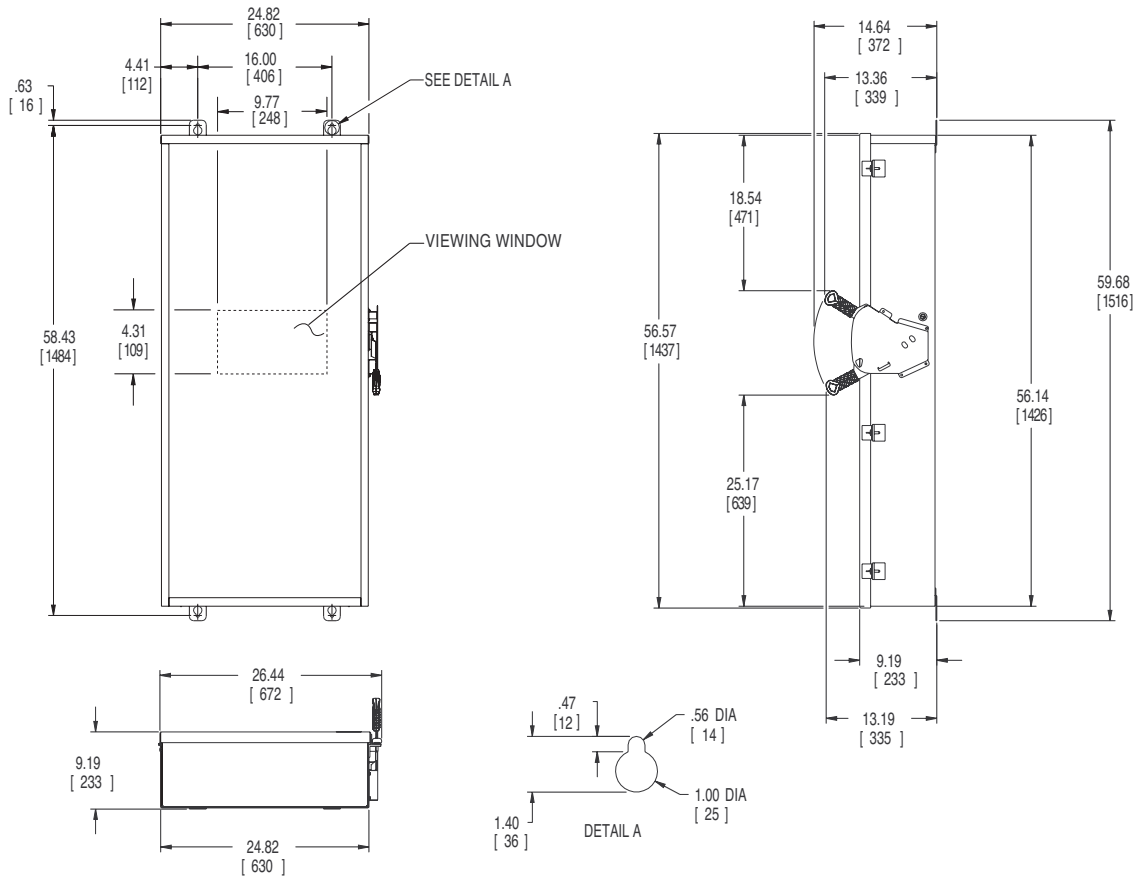

No knockouts in enclosures.
 Dimensions shown in inches and millimeters ().
 Dimension shown accurate to $\pm \frac{1}{8}$ inch.

	LINE SIDE WIRE BEND	LOAD SIDE WIRE BEND
600V fused	17.35 (441)	15.54 (395)

Enclosure: Galvanized Steel
 .075 Thick (14 Gauge)
 Finish: ANSI Grey #61 Paint

1 If compression lugs are used, order compression lug mounting kit HCL65678.