

SIEMENS



Selection and application guide

Panelboards

usa.siemens.com/panelboards

Contents

	PAGE
Introduction	2
General Specifications	3-5
Catalog Numbering System	6

SECTION



P1 Panelboards

A detailed Table of Contents is located at the beginning of each product section.

SECTION



P2 Panelboards

SECTION



P3 Panelboards

SECTION



P4 Panelboards

SECTION



P5 Panelboards

SECTION



C1/C2 Panelboards

SECTION



Miscellaneous

Introduction

This new generation of products from Siemens offers the high level of engineering and innovation you've come to expect from the leader in power distribution technology. The "P Series" line of panelboards offers a stepped approach to power distribution.

Additional strength has been added to an already rugged and durable panelboard family. Engineered specifically to provide maximum flexibility, the new designs simplify wiring and reduce material requirements making them easier to install and less costly than competitive products. At the heart of the product line is the extensive research and technology found among Siemens circuit protection devices – both fusible switches and molded case circuit breakers.

The line is anchored by the innovative P1. Featuring the industry's most flexible designs, the P1 virtually eliminates common errors, such as feed direction, and main lug versus main breaker. Increasing distribution is simplified by the ability to add feed-thru lugs. Because of its unique design, the P1 meets the majority of lighting panel needs with only six standard sizes.

Subsequent steps in the P Series offer increased capacity and more design options:

- The highly flexible P2 provides options to fit the most demanding specifications.

- Sized more like a lighting panel, the P3 packs the power of a distribution panel in a space-saving, highly flexible design.
- The P4 is a mid-sized distribution panel that allows both fusible and circuit breaker branch and main devices.
- The powerful P5 anchors the high end of the series. With larger fusible and circuit breaker branch and main devices, the venerable P5 delivers maximum power and flexibility to larger distribution systems.

Siemens also offers a number of specialty panels, like column panels. Don't see a panel to meet your requirements? Ask your Siemens representative about our custom capabilities.

Features Overview

P Series lighting panel features include Fas-Latch trim, which is popular among installers; the jacking screw system, that permits adjustments even after wiring has been installed; our exclusive split neutral, and more. Many panelboards have the capability of mixing and matching breakers of different sizes and ratings – or changing from main lug to main breaker, or adding subfeed breakers without changing the box size. Other models accept a wide range of fuse types, including Siemens exclusive Vacu-Break® technology.

Table G1 – Key Panelboard Features

	P1	P2	P3	P4	P5
Lighting And Appliance Applications (Pre 2008 NEC)	•	•	•	•	•
Power Panelboard Applications	—	•	•	•	•
Convertible From Top Feed To Bottom Feed Or Vice Versa	•	—	—	—	—
Change From Main Lug To Main Breaker Or Add Subfeed Without Changing Enclosure Size	•	—	—	—	—
Space-Saving, Horizontally Mounted Main Breaker	Up To 250 Amps	Up To 250 Amps	Up To 250 Amps	•	•
Short-Circuit Rating Label Giving Performance Level	•	•	•	•	•
Standard Aluminum Ground Assembly	•	•	•	•	•
Blank End-Walls Standard ¹	•	•	•	•	•
Bolted Current-Carrying Parts	•	•	•	•	•
Split Neutral	•	•	•	•	•
Connection Accessible From Front	•	•	•	•	•
Screw-Type Mechanical Lugs	•	•	•	•	•
Time-Reducing Wing Nuts To Secure Interior Without Tools	•	•	•	•	•
Main and Branch Devices Connected With Case-Hardened Hardware	•	•	•	•	•
Flush Lock, Concealed Door Hinges/Trim Screws	•	•	•	—	—
Symmetrical Interior Mounting Studs To Eliminate Upside-Down Mounting of Box	•	•	•	•	•
Interior Height Adjustment For Flush Applications	•	•	•	•	•
Mix and Match Fusible Switch Circuit Breaker Capability	—	—	—	•	•
Shallow Depth	5.75"	5.75"	7.75"	10.00"	12.75"
Accepts A Wide Range Of Fuse Types	—	—	—	•	•
Accepts Vacu-Break Fusible Switch	—	—	—	•	•
Accepts A Wide Range Of Circuit Breakers	—	•	•	•	•
Accepts ACCESS™ Communications Tie-In ²	—	•	•	•	•
Optional Compression Lugs	•	•	•	•	•

• Standard

¹ KO's available on P1 and P2 – 5.75" Deep x 20" Wide boxes and P3 7.75" deep X 24" wide boxes.

² Panelboards equipped with Siemens Sensitrip® circuit breakers or Power Meters can be integrated into Siemens ACCESS™ electrical monitoring system.

General Specifications

Class CTL Panelboards (when applicable)

Class CTL panelboards incorporate physical features which, in conjunction with the physical size, configuration, or other means provided in Class CTL circuit breakers, are designed to prevent the installation of more over current protective poles than the number for which the device is designed and rated, per UL 67 and National Electrical Code (NEC) NFPA70.

Service Entrance Equipment

When a panelboard is used as service entrance equipment, it must be located near the point of entrance of building supply conductors. In a main lugs only panel, the number of breakers or switches directly connected to the main bus must be limited to six. In a panel having a main breaker or main switch, the number of circuits are not limited except as may be provided under other panelboard requirements, i.e., lighting and appliance branch circuit panelboards. Also, panels must include a connector for bonding and grounding neutral conductor.

Panelboard Code Data (where applicable)

42-Circuit Rule: NEC Paragraph 408.14 defines a lighting and appliance branch circuit panelboard as one having more than 10 percent of its over current devices rated 30 amperes or less, for which neutral connectors are provided. NEC paragraph 480.35 states that not more than 42 over current devices (other than those provided in the mains) of a lighting and appliance branch-circuit panelboard shall be installed in any one cabinet. For the purpose of this publication, a two-pole circuit breaker shall be considered two over current devices; a three-pole circuit breaker shall be considered three over current devices. (NEC 480.34 and .35 do not apply to panelboards feeding and communication circuits. Panelboards for this application must be so marked.)

Integrated Equipment Short Circuit Rating

The term "Integrated Equipment Short Circuit Rating" refers to the application of series connected circuit breakers in a combination that allows some breakers to have lower individual interrupting ratings than the available fault current. This is permitted as long as the series combination has been tested and certified by UL.

Standards

NEC: 2008 (where accepted)

NEMA: PB1

UL: 67 and 50. Listed by Underwriter's Laboratories, Inc., under "Panelboards" File #E2269, and #E4016. Meets Federal Specification W-P-115c.

Wire Connectors

Standard wire connectors in Siemens panels are suitable for copper or aluminum cables rated 60/75 degree. Copper main lugs are a price-added option for most panel types and some Circuit Breakers (check with Siemens sales for availability). It should be noted that most copper lugs will only accept copper cables. Some applications, 100% rated devices in particular,

require that the cable and connectors be rated 90 degree but are sized to the 75 degree tables.

Standard ground connectors are also suitable for copper or aluminum wire. Ground connector assemblies (EGK, IGK) have (7) 1/0 max. and (15) #6 max. connections. The 1/0 holes are capable of connecting up (3) #10 max. wires. Copper ground assemblies (ECGK, ICGK) are rated for copper wire only and have the same wiring capacity as the Al/Cu connectors.

Standard neutrals, like standard main lugs, are also rated for copper or aluminum wire. The neutral cross bar material follows the selection bus. Copper neutral lugs are rated for copper cable only and available as a price added option.

Lug Data

Space Required for Mounting of Double Panels

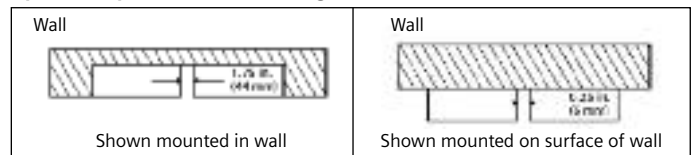

Use two or more panelboards with feed-thru or subfeed lugs when:

1. Lighting and appliance panelboards are required with more than 42 circuits in areas where the zone code has not been accepted.
2. More circuit mounting space is required than is provided in the largest box size.

Feed-Thru Lugs

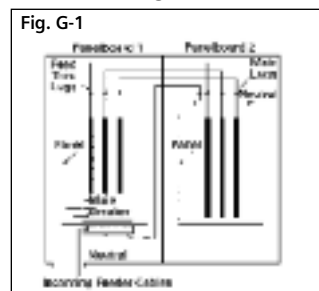

Subfeed Lugs or Double Lugs

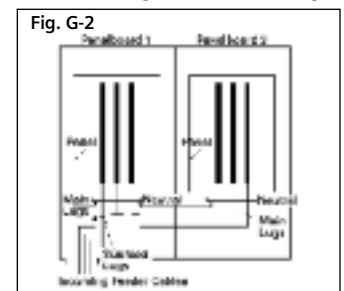

Feed-thru lugs are mounted at the opposite end of the main bus from the main lugs or main breaker and are used to connect two or more panelboards to the incoming feeder. The feeder cables are brought into Panelboard 1 and connected to the main lugs or main breaker. Cables interconnecting the two panelboards are connected to the feed-thru lugs in Panelboard 1 and are carried over the main lugs in Panelboard 2. This arrangement could be reversed with the main lugs located at the top and the feed-thru lugs at the bottom of the panel. Subfeed lugs are mounted directly beside the main incoming lugs and are used to connect two or more panelboards to the incoming feeder. The feeder cables are brought into Panelboard 1 and connected to the main lugs. Another set of cables that are the same size are connected to the subfeed lugs of Panelboard 1 and are carried over the main lugs of Panelboard 2.

General Specifications

Bussing Sequence

Interiors are designed to accommodate top or bottom feed. Regardless of which is specified, the uppermost pole is always on "A" phase; the second pole down is always on "B" phase, and the third pole down is always on "C" phase (assuming 3Ø panel).

As standard, branch breakers shall be mounted at the top of the panel with "spaces" at the bottom, regardless of the direction panel is fed.

All breakers have bolted connections except plug-in type. The panel design provides bracing up to 200,000A IR UL short circuit rating. Case-hardened, high performance, thread rolling screws are used on branch bus.

Table G2 – Panelboard Ratings

Description	P1	P2	P3	P4	P5
Max. Voltage	480Y/277V AC Max. 250V DC Max	600V AC Max. 500V DC Max.	600V AC Max. 500V DC Max.	600V AC Max. 500V DC Max.	600V AC Max. 500V DC Max.
System	1-Phase, 2-wire 1-Phase, 3-wire 3-Phase, 3-wire 3-Phase, 4-wire	1-Phase, 2-wire 1-Phase, 3-wire 3-Phase, 3-wire 3-Phase, 4-wire	1-Phase, 2-wire 1-Phase, 3-wire 3-Phase, 4-wire 3-Phase, 3-wire	1-Phase, 3-wire 3-Phase, 4-wire 3-Phase, 3-wire	1-Phase, 3-wire 3-Phase, 4-wire 3-Phase, 3-wire
Mains					
Main Lugs	125A-400A	125A-600A	250A-800A	400A-1200A	800A-1200A
Main Breaker	100A-400A	100A-600A	225A-600A	400A-800A	800A-1200A
Main Switch	—	—	—	—	200A-1200A
Circuits	18, 30, 42	18, 30, 42, 54, 66 78, 90 ¹	—	—	—
Branch Ratings	15-125A ²	15-400A	15-400A	15-800A C/B 30-200A Fusible	15-1200A C/B 30-1200 Fusible
Branch Disconnect Devices	BL, BLH, HBL, BQD, BQD6, BLE, BLEH, BLF, BLHF, BAF, BAFH, BGL, NGB	BL, BLH, HBL, BQD, BQD6, QJ2 ⁵ , HQJ2 ⁵ , QJ2H ⁵ , HQJ2H ⁵ , ED2, ED4, HED4, ED6, HHED6, BLE, BLEH, BLF, BLHF, BAF, BAFH, BGL, NGB	BL, BLH, HBL, BQD, BQD6, QJ2 ⁶ , HQJ2 ⁶ , QJ2H ⁶ , HQJ2H ⁶ , ED2, ED4, HED4, ED6, BLHF, BAF, BAFH, BGL, NGB, NEB, HEB	All 15-600A Breakers and VL MG at 800A, HHED6, BLE, BLEH, BLF, Fusible Switches 30-200A	All 15-1200A C/B 30A-600A VB Switches 400-1200A HCP
Subfeed Circuit Breakers	ED2, ED4, ED6, HED4, HHED6, QJ2, QJH2, QJ2-H, FXD6, FD6, HFD6, HFXD6 ³	JD6, JXD6, HJD6, HJXD6, FD6, HFD6, FXD6, HFXD6 ^{2 3}	JD6, JXD6, HJD6, FD6, HFD6, FXD6, HFXD6 ^{2 3}	—	—
Enclosure Heights Inches – (mm)	32, 38, 44 @250 A (813, 965, 1118) 56, 62, 68 @400 A (1422, 1575, 1727)	26, 32, 38, 44, 50, 56, 62, 68, 74 (660-1880)	56, 62, 68, 74, 80 (1422-2032)	60, 75, 90 (1524, 1905, 2286)	60, 75, 90 (1524, 1905, 2286)
Standard Trims	Fas-Latch – 1 Piece Surface or Flush	Fas-Latch – 1 Piece Surface or Flush	Fas-Latch – 1 Piece Surface or Flush	Four Piece ⁴ Surface or Flush	Four Piece ⁴ Surface or Flush

¹ Functional pricing is based on circuits shown. However, the panel can be figured with less circuits.

² P1 can have 1 subfeed breaker. P2 and P3 can have up to (2) FD subfeed breakers.

³ JD and FD breakers are mounted vertical. Limitations apply.

⁴ Trim ring provided for flush applications.

⁵ A maximum of (4) QJ breakers may be mounted in a P2 Panel and are single mounted.

⁶ A maximum of (6) QJ breakers may be mounted in a P3 panel and are twin mounted.

General Specifications

Table G3 – Typical Panelboard Modifications

Description	Lighting and Distribution Panelboards			Distribution Panelboards	
	P1	P2	P3	P4	P5
Box					
Type 3R/12	•	•	•	•	•
Type 4, 4X	•	•	•	•	•
Drip Proof	•	•	•	•	•
Drip Proof Hood Only	•	•	•	•	•
Sealed Box	•	•	•	•	•
Gasketed Trim	•	•	•	•	•
Wider Box	•	•	•	•	•
Deeper Box	—	•	•	•	•
Front					
Hinged Front	•	•	•	•	•
Door-in-Door Front	•	•	•	•	•
Common Front	•	•	•	—	—
Split Door	•	•	•	—	—
Special Locks	•	•	•	•	•
Nameplate	•	•	•	•	•
Interior					
Aluminum Equipment Ground Bar	Standard	Standard	Standard	Standard	Standard
Copper Equipment Ground Bar	•	•	•	•	•
Insulated Equipment Ground	•	•	•	•	•
Subfeed Lugs	—	•	•	•	•
Feed-Thru Lugs	•	•	•	•	•
Split Bus	—	•	•	•	•
Compression Lugs	•	•	•	•	•
Copper Lugs	•	•	•	•	•
200% Neutral	•	•	•	400 - 600A	400 - 600A
Temperature Rated - Aluminum ¹	Standard	Standard	Standard	Standard	Standard
Temp. Rise Over Ambient - Copper ¹	•	•	•	•	•
750 Ampere / in. - Aluminum	—	•	•	•	•
1000 Ampere / in. - Copper	—	•	•	•	•
Copper Plating	Tin	Tin Std./ Silver Optional	Tin Std./ Silver Optional	Silver	Silver
Remote Control Switches	External Mounted	•	•	•	•
Time Clocks	External Mounted	•	•	•	•
Circuit Breaker Shunt Trips	•	•	•	•	•
R, J and T Fuse Clips	—	—	—	•	•

All aluminum bus is tin-plated. • Available as an option.

Table G4 – UL Fuse Classes

Class	Amperes	Volts	Interrupting Ratings (kA)	I _t , I _i	Circuits
H	1-600	250 and 600V or less AC	10	—	Less than 10,000A Available
K5 ²	1-600	250 and 600V or less AC	100	I _t – RK5 up to 100A, I _i – RK5 up to 100A	Feeder circuits
J	1-600	600V or less	200	I _t – Low, I _i – Low	Feeder circuits (motor load small %)
RK1	1/10 - 600	600V or less and 250V or less	200	I _t – Slightly >J, I _i – Slightly > J	Feeder circuits (motor load small %)
RK5	1/10 - 600	600V or less and 250V or less	200	I _t – > RK-1, I _i – > RK-1	Motor starting currents a factor
T	1 - 800, 1 - 1200	300 and 600V or less AC	To 200	I _t – Low, I _i – Low	Non-Motor loads
L	601 - 1200	600V or less	200	I _t – Low, I _i – Low	Mains, feeder circuits

¹ Per UL 67.

² Fuses do not prohibit the use of Class H type fuse in switch.

Catalog Numbering System

P 1 C 4 2 F X 2 5 0 A T S

Type of Panel

P1, P2, P3, P4, P5

Voltage and System

C= 208Y/120 3Ø 4 W Wye AC - All
 E= 480Y/277 3Ø 4 W Wye AC - All
 D= 240 3Ø 3 W Delta AC - All
 F= 480 3Ø 3 W Delta AC - P2, P3, P4, P5
 G= 600 3Ø 3 W Delta AC - P2, P3, P4, P5
 I= 347AC - P2, P3, P4, P5
 B= 240/120 3Ø 4 W Delta BØ High Leg AC - All
 Q= 240/120 3Ø 4 W Delta CØ High Leg AC - P2, P3, P4, P5
 X= 120/240 2Ø 5 W Single Neutral AC - P2, P3, P4, P5
 A= 120/240 1Ø 3 W Grounded Neutral AC (2) - All
 H= 120 1Ø 2 W Grounded Neutral AC (2) - All
 J= 240 1Ø 2 W No Neutral AC (3) - All
 Y= 125 1Ø 2 W Grounded Neutral AC (2) - P2, P3, P4, P5
 Z= 500 2W DC - P2, P3, P4, P5
 K= 220/127 3Ø 4 W Wye AC - All
 M=380/220 3Ø 4 W Wye AC - All

R= 415/240 3Ø 4 W Wye AC - All
 S= 440/250 3Ø 4 W Wye AC - All
 L= 600/347 3Ø 4 W Wye AC - All
 T= 230 3Ø 3 W Delta AC - All
 W=380 3Ø 3 W Delta AC - P2, P3, P4, P5
 1= 24V DC 1 Pole Branches Only (3) - All
 2= 24V DC 2 Pole Branches Only (3) - All
 3= 48V DC 1 Pole Branches Only (3) - All
 4= 48V DC 2 Pole Branches Only (3) - All
 5= 125V DC 1 Pole Branches Only (3) - All
 N= 125V DC 2 Pole Branches Only - All
 O= 125/250V DC 2 Pole Branches Only - All
 P= 125/250V DC 2 & 3 Pole Branches - All
 U= 120V AC 3Ø3w - All
 V= 24V 3Ø3w Grounded B Phase - All

Circuits

P1 – 18, 30, 42

P2 – 18, 30, 42, 54¹

or Enclosure Height

P3 – 56, 62, 68, 74, 80

P4, P5 – 60, 75, 90

Main Lug (ML), Main Breaker

(See Main Breaker Table coding below), Main Switch (MS)

Amperage

100–400 Amp = P1

250–800 = P3

100–600 = P2

400–1200 = P4, P5

Bus Material

Temp rated Al.

750A/sq. in. Al.

Temp rated Cu.

Temp rated Cu.

Temp rated Cu.

1000A/sq. in. Cu.

1000A/sq. in. Cu.

Bus Plating

Tin-Plated

Tin-Plated

Tin-Plated

Silver-Plated

Tin-Plated

Tin-Plated

Silver-Plated

Letter

A

B

C

E

F

G

H

Bus Code	P1 ²	P2	P3	P4	P5
A	•	•	•	•	•
B	n/a	•	•	•	•
C	•	•	•	n/a	n/a
F	n/a	•	•	•	•
E	n/a	•	•	•	•
G	n/a	•	•	optional	optional
H	n/a	optional	optional	•	•

• indicates default for this bus type.

Feed Location

T = Top

B = Bottom

Mounting

S = Surface

F = Flush. Flush trims extend 1 1/2" beyond the base box dimensions on P1, P2 and P3 and 2" on P4 and P5 panels.

Main Breaker Code

(Breaker Type) Code

(BAF) BA, (BAFH) BF, (BQD) BQ, (BQD6) B6, (BL) BL, (BLEH) BE, (BLH) BH, (BLR) BR, (HBL) HB, (BGL-SWI) B1, (BLE-GFCI) BG, (BLF-GFCI) BC, (CED6) CE, (ED2) ED, (ED4) E4, (ED6) E6, (HED4) H4, (HHED6) HA, (BLHF-GFCI) B4, (BL-HID) B2, (NGB) NB, (HQP) HQ, (QP) QP, (QPH) PQ, (CEG) C4, (QJ2) QJ, (QJ2H) Q2, (QJH2) QH, (HQJ2H) Q3, (CFD6) CF, (FD6) FD, (FXD6) FX, (HFD6) HF, (HFXD6) H2, (HHFD6) H1, (HHFXD6) H3, (CJD6) CJ, (HHJD6) H4, (HHJXD6) H9, (HJD6) H6, (HJXD6) H5, (HJXD6H) H7, (JD6) J6, (JXD2) JD, (JXD2H) J2, (JXD6) JX, (JXD6H) JH, (NJX) J1, (HJX) J7, (LJX) J3, (NJY) J4, (SJD6H) SH, (SJD6) SJ, (SHJD6) SX, (SHJD6H) SY, (SCJD6) SC, (HJY) J5, (LJY) J8, (CLD6) CL (HHLD6) HH, (HHLXD6) XH, (HLD6) HL, (HLXD6) HO, (HLXD6H) HP, (LD6) L6, (LXD6) LX, (LXD6H) LH, (NLX) L7, (HLX) L2, (LLX) L3, (SLD6) SL, (SHLD6) S2, (SCLD6) S1, (HLMD6) HJ, (HLMXD6) HK, (LMD6) L1, (LMXD6) LM, (CMD) CM, (CMD6) CH, (HMD6) HM, (HMXD6) HR, (HMXD6H) HS, (MD6) MD, (MXD6) MX, (MXD6H) MH, (NMX) M1, (HMX) M2, (LMX) M3, SCMD6 (SO), SCMD6H (SQ), SMD6 (SM), SMD6H (AX), SHMD6 (S5), SHMD6H (S6)(CND6) CN, (CND6H) C6, (HND6) HN, (HNXD6) HT, (HNXD6H) HX, (ND6) ND, (NXD6) NX, (NXD6H) NT, (NNX) N1, (HNX) N2, (LNX) N3, (NNY) N4, (HNY) N5, (LNY) N6, SCND6 (SR), SCND6H (ST), SND6 (SN), SHND6 (AD), SND6H (AY), SHND6H (AE)

¹ Panel must not be a lighting and appliance panel. See NEC article 408.34.

² Standard bussing in P1 panels is tin-plated for aluminum and copper. Standard bus is temperature rated to the maximum amperage.

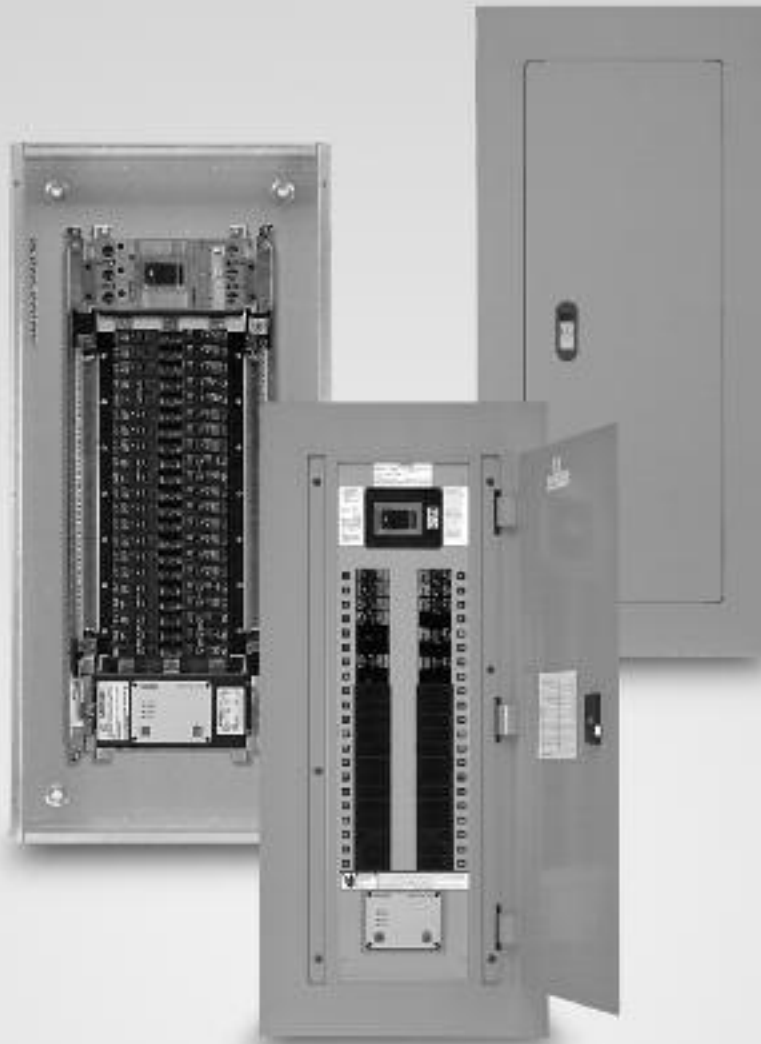

P1 Panelboards

Description	Page		
General Information	1-2	Side Gutter Wiring Space	1-6
Selection and Application	1-2	Branch Breaker Side Gutters	1-6
Application	1-3 – 1-6	Typical Catalog Numbers	1-7
Main Breaker Panel Size Selector	1-3	Main Lugs Only	1-7
Main Breaker Selection	1-3	Main Circuit Breaker	1-7
Main Lugs Size Selector	1-4	Standard Enclosures	1-7
Branch Circuit Breakers	1-4	Standard Modifications	1-8
Subfeed Breakers	1-5	Connector Modifications	1-9
Breaker Mounting Kits	1-5	Compression Lugs	1-9
Lug Kits	1-5	Enclosure Modifications	1-9
Main Breaker Gutter Dimensions	1-6	Remote Switch Modifications	1-9
Main Lug End Gutter Dimensions	1-6	Dimensions	1-10

Type P1 Panelboards

P1 panelboards are pre-engineered to accept the most common modifications without increasing box height. The enclosure size is determined by the number of circuits as shown in the Main Lug Table P1-5 or the Main Circuit Breaker Table P1-3. All P1 main lug or main breaker panelboards have space built-in to accept either feed-thru lugs equal to the panel rating, one subfeed circuit breaker up to 250 amperes or a surge suppressor (TVSS) without increasing box height.

Note the following features, all found in the innovative P1 lighting panelboards:

- Symmetrical Interiors - No top or bottom! To change from top to bottom (or vice-versa), simply invert the interior. The deadfront labeling is always right-side up.
- First in the Industry Ratings of 125 through 400A main lug and main breaker. Field convertible from main lug to main breaker and vice versa – with no increase in enclosure height.
- Field adaptability of feed-thru lugs or subfeed circuit breaker without increasing enclosure size.
- Neutral system is field upgradeable to 200% capacity – another industry first.
- Three circuit sizes means only three box heights, regardless of main configuration through 250 amp and an additional three circuit version and boxes available at 400 amps.
- Suitable for use as service entrance given compliance with NEC.
- Bonding provisions are shipped with each panel.
- 240V and 480Y / 277V for versions utilize identical boxes and fronts.

Enclosure – Standard Type 1 enclosure is 20" wide x 5.75" deep. Box Height is determined only by the number of circuits, not by main lug or main circuit breaker. See chart P1-5 for box height.

Selection and Application

3 Easy Steps for Selecting a Siemens P1 Panelboard

Step 1

Determine voltage, system, amperage and interrupting rating of branch devices, and modifications if any.

Example for standard lighting panelboard:

Amperage	250A
Voltage	208Y/120V
System	3Ø4W
Main	Main Lug
Branches	10K AIR, 42-20/1
Modifications	None
Feed Location	Top
Mounting	Surface

Step 2

Create a catalog number by following the Panelboard Catalog Numbering System on page 6. The BL branch breakers were selected from the branch breaker selection table on page 1-4.

1-P1C42ML250ATS
42-20/1 BL

Step 3

Select enclosure size by the number of circuits as shown in the panelboard dimensional chart on page 1-6.

1-P1C42ML250ATS
42-20 BL
Box size – 44" high

A unique feature of P1 panels is that they can accommodate either feed-thru lugs or one subfeed circuit breaker (up to 250A) without any addition to box height. For our example changing the branch circuits to 39-20/1 and 1-125/3, we have the following:

1-P1C42ML250ATS
39-20/1 BL
1-125/3 QJ2
Box size – 44" high

The QJ2 subfeed was selected from the table of subfeed breakers on page 1-5. The box height remains the same.

Voltage – 480Y/277 Vac max.
250 Vdc max.

Amperage – 400 amp max.

Short Circuit Rating – 200 KAIC max. symmetrical or equal to the lowest rated device installed unless a series rating is indicated. Panels with subfeed or feed-thru lugs without a main device, circuit breaker or fusible unit, are limited to a three-cycle rating. The three-cycle rating for the P1 panel is limited to 22 KAIC. Note that the main device may be mounted remote from the panel.

Bussing – The P1 panel meets the majority of the markets bussing requirements. The standard bussing is temperature rated aluminum. The rating is per the requirements of UL 67– the standard for panelboards. All aluminum bussing is tin-plated. Optional bussing for the P1 panel is temperature rated copper. The copper bus option for this panel is tin-plated.

Weight – Approximate

Total panelboard weight when filled with a normal quantity of breakers and accessories is about 3 lbs. (1 kg) per inch (54g per mm) of box height

Table P1-1 – Box Material Gauge

Width	Height (inches)	Gauge Steel
20"	32, 38, 44	#16
	56, 62, 68	

Table P1-2 – Trim Material Gauge

20"	32, 38, 44	#14
	56, 62, 68	

Application

Type P1 Panelboards

Table P1-3 – Main Breaker Panel Size Selector

Maximum Ampere Rating	Main Breaker Types	Max. No. of Poles	Dimensions in Inches (mm)		
			Unit Space A	Box Height B	Weight In lbs. (kg)
100	BL, BLH	18 30 42	9 (229)	32 (813)	105 (48)
	HBL		15 (381)	38 (965)	120 (55)
	BQD		21 (533)	44 (1118)	135 (61)
125	NGB		9 (229)	32 (813)	110 (50)
			15 (381)	38 (965)	125 (57)
			21 (533)	44 (1118)	140 (64)
225	ED2, ED4, ED6, HED4, HED6		9 (229)	32 (813)	110 (50)
			15 (381)	38 (965)	125 (57)
			21 (533)	44 (1118)	140 (64)
250	QJ2		9 (229)	32 (813)	110 (50)
	QJH2		15 (381)	38 (365)	125 (57)
	QJ2-H		21 (533)	44 (1118)	140 (64)
250	FXD6	9 (229)	32 (813)	115 (52)	
	FD6	15 (381)	38 (965)	130 (59)	
	HFD6, HFXD6	21 (533)	44 (1118)	145 (66)	
≤ 250	MLO	9 (229)	32 (813)	115 (52)	
		15 (381)	38 (365)	125 (57)	
		21 (533)	44 (1118)	135 (61)	
400	JD6, JXD6	18 30 42	9 (229)	56 (1422)	172 (78)
	HJD6		15 (381)	62 (1575)	190 (86)
	HJXD6		21 (533)	68 (1727)	208 (95)
			9 (229)	56 (1422)	115 (52)
	MLO		15 (381)	62 (1575)	130 (59)
		21 (533)	68 (1722)	145 (66)	

Note: Main breakers use breaker connectors. For sizes, see breaker connector chart. 400 amp main breaker panel has wire bending space for 600 kcmil cables as standard. Use 750 Kcmil lug if 600 Kcmil cable is to be used.

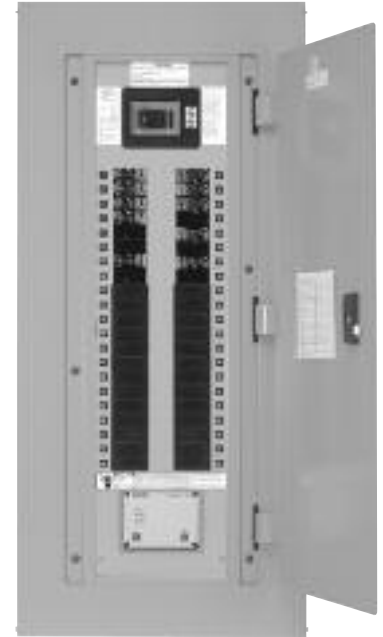
Table P1-4 – Main Breaker Selection

Ampere Rating	Breaker Type	Max. IR (kA) at		Additional Trip Values
		240V AC	480/277V AC	
100	BL (STD)	10	—	15, 20, 25, 30, 35, 40, 45, 50, 60, 70, 80, 90, 100
	BLH	22	—	15, 20, 25, 30, 35, 40, 45, 50, 60, 70, 80, 90, 100
	HBL	65	—	15, 20, 25, 30, 35, 40, 45, 50, 60, 70, 80, 90, 100
	BQD	65	14	15, 20, 25, 30, 35, 40, 45, 50, 60, 70, 80, 90, 100
125	NGB (STD)	100	25	50, 60, 70, 80, 90, 100, 110, 125
	ED4 (STD)	65	25	50, 60, 70, 80, 90, 100, 110, 125
	HED4	100	42	50, 60, 70, 80, 90, 100, 110, 125
225	QJ2 (STD)	10	—	60, 70, 80, 90, 100, 110, 125, 150, 175, 200, 225
	QJH2	22	—	60, 70, 80, 90, 100, 110, 125, 150, 175, 200, 225
	QJ2-H	42	—	60, 70, 80, 90, 100, 110, 125, 150, 175, 200, 225
	HQJ2H	100	—	60, 70, 80, 90, 100, 110, 125, 150, 175, 200, 225
250	FXD6 (STD)	65	35	70, 80, 90, 100, 110, 125, 150, 175, 200, 225, 250
	FD6	65	35	70, 80, 90, 100, 110, 125, 150, 175, 200, 225, 250
	HFD6	100	65	70, 80, 90, 100, 150, 175, 200, 225, 250
	HFXD6	100	65	70, 80, 90, 100, 110, 125, 150, 175, 200, 225, 250
400	JXD6 (STD)	65	35	200, 225, 250, 300, 350, 400
	JD6	65	35	200, 225, 250, 300, 350, 400
	HJD6	100	65	200, 225, 250, 300, 350, 400
	HJXD6	100	65	200, 225, 250, 300, 350, 400

Application

Type P1 Panelboards

Table P1-5 – Main Lugs Size Selector

Maximum Ampere Rating	Maximum Number of Poles	Dimensions in Inches (mm)		Weight In lbs. (kg)	Connectors Suitable for
		Unit Space A	Height B		
125	18	9 (229)	32 (813)	100 (45)	(1) #6 AWG - 350 kcmil
	30	15 (381)	38 (965)	115 (52)	
	42	21 (533)	44 (1118)	135 (61)	
250	18	9 (229)	32 (813)	100 (45)	(1) #6 AWG - 350 kcmil
	30	15 (381)	38 (965)	115 (52)	
	42	21 (533)	44 (1118)	175 (80)	
400	18	9 (229)	56 (1422)	100 (45)	(2) #3/0-250 kcmil or (1) #3/0-600 kcmil
	30	15 (381)	62 (1575)	115 (52)	
	42	21 (533)	68 (1727)	175 (80)	

Table P1-6 – Branch Circuit Breakers

Breaker Type	Number of Poles	Max. Interrupting Rating (kA)					Available Trip Values
		120V	120/240V	240V	277V	480/277V	
BL	1	10	—	—	—	—	15, 20, 25, 30, 35, 40, 45, 50, 55, 60, 70
	2	—	10	—	—	—	15, 20, 25, 30, 35, 40, 50, 60, 70, 80, 90, 100
	3	—	—	10	—	—	15, 20, 25, 30, 35, 40, 50, 60, 70, 80, 90, 100
BLR	2	—	—	10	—	—	15, 20, 30, 40, 50, 60, 70, 90, 100
BL, HID	1	10	—	—	—	—	15, 20, 30
	2	—	10	—	—	—	15, 20, 30
BLH	1	—	22	—	—	—	15, 20, 30, 40, 50, 55, 60, 70
	2	—	22	—	—	—	15, 20, 30, 40, 50, 60, 70, 90, 100
	3	—	—	22	—	—	15, 20, 30, 40, 50, 60, 70, 80, 90, 100
HBL	1	—	65	—	—	—	15, 20, 30, 40, 50
	2	—	65	—	—	—	15, 20, 30, 40, 50, 60, 70
	3	—	—	65	—	—	15, 20, 30, 40, 50, 60, 70, 80, 90, 100
BLF	1	10	—	—	—	—	15, 20, 30
	2	—	10	—	—	—	15, 20, 30, 40, 50, 60
BLHF	1	22	—	—	—	—	15, 20, 30
	2	—	22	—	—	—	15, 20, 30, 40, 50, 60
BGL ¹	2	10	—	—	—	—	15, 20, 30
	3	—	10	—	—	—	15, 20, 30
BLE	1	10	—	—	—	—	15, 20, 30
	2	—	10	—	—	—	15, 20, 30, 40, 50, 60
BLEH	1	22	—	—	—	—	20, 30
	2	—	22	—	—	—	15, 20, 30, 40, 50, 60
BAF	1	10	—	—	—	—	15, 20
BAFH	1	22	—	—	—	—	15, 20
BQD	1	—	65	—	14	—	15, 20, 25, 30, 35, 40, 50, 60, 70, 80, 90, 100
	2	—	65	—	—	14	
	3	—	—	65	—	14	
NGB ²	1	100	—	—	25	—	15, 20, 25, 30, 35, 40, 50, 60, 70, 80, 90, 100, 125
	2	—	100	100	—	25	
	3	—	100	100	—	25	

¹ Two-pole breaker is one phase and neutral. Three-pole is two phases and neutral.

² P1 panel with NGB branch devices will not accept BL or BQD frames in the same panel as branch devices.

NOTE: BL, HBL and BQD breakers are mounted in common mountings in 3" or (6) pole increments.

Application

Type P1 Panelboards

Table P1-7 – Subfeed Breakers

Breaker Type	Number of Poles	Max. Interrupting Rating (kA)		Available Trip Values
		240V	480Y/277V	
QJ2	2, 3	10	—	60, 70, 80, 90, 100, 110, 125, 150, 175, 200, 225
QJH2	2, 3	22	—	60, 70, 80, 90, 100, 110, 125, 150, 175, 200, 225
QJ2H	2, 3	42	—	60, 70, 80, 90, 100, 110, 125, 150, 175, 200, 225
HQJ2H	2, 3	100	—	60, 70, 80, 90, 100, 110, 125, 150, 175, 200, 225
ED4	2, 3	65	18	15, 20, 25, 30, 35, 40, 45, 50, 55, 60, 70, 80, 90, 100, 110, 125
HED4	2, 3	100	42	15, 20, 25, 30, 35, 40, 45, 50, 55, 60, 70, 80, 90, 100, 110, 125
FXD6	2, 3	65	35	70, 80, 90, 100, 110, 125, 150, 175, 200, 225, 250
FD6	2, 3	65	35	70, 80, 90, 100, 110, 125, 150, 175, 200, 225, 250
HFD6	2, 3	100	65	70, 80, 90, 100, 110, 125, 150, 175, 200, 225, 250
HFXD6	2, 3	100	65	70, 80, 90, 100, 110, 125, 150, 175, 200, 225, 250

Table P1-8 – Breaker Mounting Kit
Main or Subfeed w/o Breaker

Amp Rating	Breaker Frames	Service	Catalog Number
100	BL, BLH, HBL	1 Phase	MBKBL1
		3 Phase	MBKBL3
	BQD	3 Phase	MBKBC3
125	NGB	1 Phase	MBKNB1
		3 Phase	MBKNB3
	ED2, ED4, ED6, HED4, HED6	1 Phase	MBKED1
		3 Phase	MBKED3
225	QJ2, QJH2, QJ2-H	1 Phase	MBKQJ1
		3 Phase	MBKQJ3
250	FXD6, FD6, HFD	1 Phase	MBKFD1
		3 Phase	MBKFD3
400 ¹	JD2, JD6, JXD6, HJD6, HJXD6	1 Phase	MBKJD1
		3 Phase	MBKJD3

¹Main Only

Table P1-9 – Lug Kits Main or Feed-Thru

Amp Rating	Material	Wire Range	Service	Catalog Number
250	Al	(1) #6 AWG-350 Kcmil (Cu or Al)	1 Phase	MLKA1
		(1) #6 AWG-350 Kcmil (Cu or Al)	3 Phase	MLKA3
	Cu	(1) #6 AWG-350 Kcmil (Cu or Al)	1 Phase	MLKC1
		(1) #6 AWG-350 Kcmil (Cu or Al)	3 Phase	MLKC2
400	AL	(2) 3/0 - (1) 250 Kcmil or (1) 600 Kcmil	1 Phase	4MLKA1
		(2) 3/0 - (1) 250 Kcmil or (1) 600 Kcmil	3 Phase	4MLKA3
		(1) 600 Kcmil	1 Phase	4MLKC1
	Cu	(1) 600 Kcmil	1 Phase	4MLKC1
		(1) 600 Kcmil	3 Phase	4MLKC3
		(1) 600 Kcmil	3 Phase	4MLKC3

Table P1-10 – Copper Neutral Lug Kits – 250A and 400A

No. of Circuits	Description	Catalog Number
18	2 Branch Neutral Strips, 1 Main Neutral Lug, Hardware	CNLK18
30	2 Branch Neutral Strips, 1 Main Neutral Lug, Hardware	CNLK30
42	2 Branch Neutral Strips, 1 Main Neutral Lug, Hardware	CNLK42

Table P1-11 – 200% Neutral Lug Kits – 250A

No. of Circuits	Description	Catalog Number
18	2 Branch Neutral Strips, 2 Main Neutral Lug, Hardware	2NLK18
30	2 Branch Neutral Strips, 2 Main Neutral Lug, Hardware	2NLK30
42	2 Branch Neutral Strips, 2 Main Neutral Lug, Hardware	2NLK42

Table P1-12 – 200% Neutral Lug Kits – 400A

No. of Circuits	Description	Catalog Number
18	2 Branch Neutral Strips, 4 Main Neutral Lug, Hardware	42NLK18
30	2 Branch Neutral Strips, 4 Main Neutral Lug, Hardware	42NLK30
42	2 Branch Neutral Strips, 4 Main Neutral Lug, Hardware	42NLK42

Application

Type P1 Panelboards

Table P1-13 – Main Breaker Gutter Dimensions Inches (mm)

Main Breaker	Gutter		Neutral Location
	20" wide box	24" wide box	20" wide box
BL, BLH, HBL, BQD	8.500 (216)	10.500 (267)	11.500 (292)
NGB	8.000 (203)	10.000 (254)	11.500 (292)
ED2, ED4, ED6, HED4	6.125 (156)	8.125 (206)	11.500 (292)
QJ2, QJH2, QJ2-H	6.500 (165)	8.500 (216)	11.500 (292)
FD6, FXD6, HFD6	5.250 (133)	7.250 (184)	11.500 (292)
JD6, JXD6 ¹	15.000 (381)	15.000 (381)	26.750 (680)

¹ JD frame mounted vertically.

Table P1-14 – Main Lug End Gutter Dimensions Inches (mm)

Amp Rating	End Gutter		Neutral Location	
	20" wide box	24" wide box	20" wide box	24" wide box
125	10.500 (267)	10.500 (267)	11.500 (292)	11.500 (292)
250	10.500 (267)	10.500 (267)	11.500 (292)	11.500 (292)
400	25.500 (648)	25.500 (648)	26.750 (680)	26.750 (680)

NOTE: Feed-thru lug and neutral wire bending space is 15.000" and 16.250" respectively on 400A panel.

Table P1-15 – Side Gutter Wiring Space Inches (mm) (Fig P1-1)

Reference Letter	Panel Width 20"	Panel Width 24" Optional
A	6.375 (162)	8.375 (213)
B	5.500 (140)	7.500 (191)
C	5.000 (127)	7.000 (178)
D ¹	6.125 (156)	8.125 (206)
E ¹	6.500 (165)	8.500 (216)
F ¹	5.250 (133)	7.250 (184)

¹ Subfeed mounting limit 1 per panel.

Fig P1-1

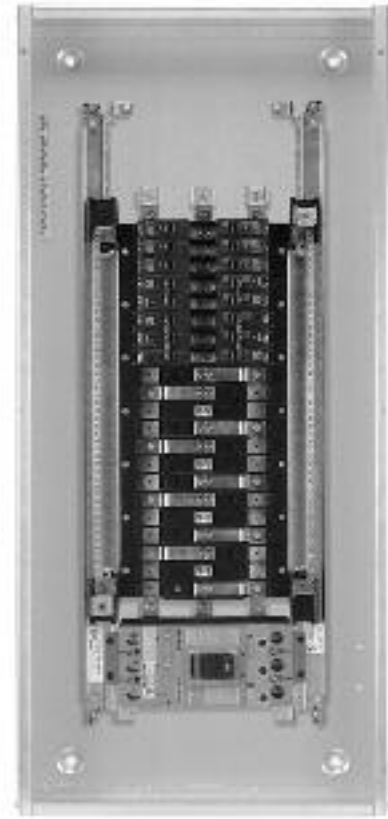
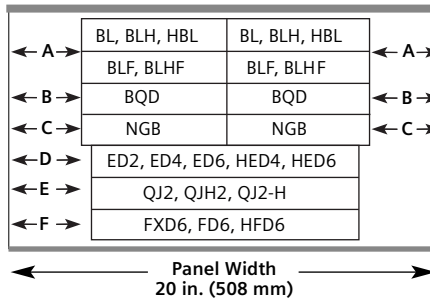

Typical Catalog Numbers

Type P1 Panelboards

Table P1-16 – Main Lugs Only

Maximum Panel Amp Rating	Maximum 1-Pole Circuits	Box Height (inches)	Catalog Number		
			3Ø4W 208Y/120V	1Ø3W 120/240V	3Ø4W 480Y/277V
125	18	32	P1C18ML125ATS	P1A18ML125ATS	P1E18ML125ATS
	30	38	P1C30ML125ATS	P1A30ML125ATS	P1E30ML125ATS
	42	44	P1C42ML125ATS	P1A42ML125ATS	P1E42ML125ATS
250	18	32	P1C18ML250ATS	P1A18ML250ATS	P1E18ML250ATS
	30	38	P1C30ML250ATS	P1A30ML250ATS	P1E30ML250ATS
	42	44	P1C42ML250ATS	P1A42ML250ATS	P1E42ML250ATS
400	18	56	P1C18ML400ATS	P1A18ML400ATS	P1E18ML400ATS
	30	62	P1C30ML400ATS	P1A30ML400ATS	P1E30ML400ATS
	42	68	P1C42ML400ATS	P1A42ML400ATS	P1E42ML400ATS

Table P1-17 – Main Circuit Breaker

100	18	32	P1C18BL100ATS	P1A18BL100ATS	P1E18BD100ATS
	30	38	P1C30BL100ATS	P1A30BL100ATS	P1E30BD100ATS
	42	44	P1C42BL100ATS	P1A42BL100ATS	P1E42BD100ATS
125	18	32	P1C18NB125ATS	P1A18NB125ATS	P1E18NB125ATS
	30	38	P1C30NB125ATS	P1A30NB125ATS	P1E30NB125ATS
	42	44	P1C42NB125ATS	P1A42NB125ATS	P1E42NB125ATS
225	18	32	P1C18QJ225ATS	P1A18QJ225ATS	P1E18QJ225ATS
	30	38	P1C30QJ225ATS	P1A30QJ225ATS	P1E30QJ225ATS
	42	44	P1C42QJ225ATS	P1A42QJ225ATS	P1E42QJ225ATS
250	18	32	P1C18FX250ATS	P1A18FX250ATS	P1E18FX250ATS
	30	38	P1C30FX250ATS	P1A30FX250ATS	P1E30FX250ATS
	42	44	P1C42FX250ATS	P1A42FX250ATS	P1E42FX250ATS
400	18	56	P1C18JX400ATS	P1A18JX400ATS	P1E18JX400ATS
	30	62	P1C30JX400ATS	P1A30JX400ATS	P1E30JX400ATS
	42	68	P1C42JX400ATS	P1A42JX400ATS	P1E42JX400ATS

Table P1-18 – Standard Enclosures

Box Height (in.)	Catalog Number				
	Type 1 Standard Trim			Type 3R	Type 3R/12
	Box	Surface	Flush		
32	B32	S32B	F32B	NR32	WP32
38	B38	S38B	F38B	NR38	WP38
44	B44	S44B	F44B	NR44	WP44
56	B56	S56B	F56B	NR56	WP56
62	B62	S62B	F62B	NR62	WP62
68	B68	S68B	F68B	NR68	WP68

Standard Modifications

Type P1 Panelboards

Panel Options

Enclosures

- Extra gutter to sides or ends of the can
- 24" wide boxes
- Hinged trims
- Door-in-door trims
- Screw to the box trims
- Painted boxes
- Custom colors
- Increase gauge trims and boxes
- Stainless steel trims and boxes, Type 1
- Aluminum trims and boxes, Type 1

Panel Modifications

- Main Bus
Standard main bus is tin-plated aluminum. For copper main bus, add from the table for each panel. Includes copper neutral cross bar. For copper neutral branch lugs, see miscellaneous.
- Compression lug for MLO¹
- Contactor mains - Mount in 23" enclosure ahead of panel.
 - Asco 920 through 225 amps³
 - Asco 911 through 150 amps³
 - Siemens LEN through 30 amps³
- Branch and main breaker accessories
 - Handle blocks
 - Handle locks
- Feed-thru lugs¹
Cannot be used in conjunction with TVSS or subfeed breakers. Do not add height to the panel.

Amp Rating	Type	Connector Cu/Al Range
250	Al Lay-in	(1) - #6 AWG -
	Mechanical	(1) 350 Kcmil
250	Cu Lay-In	(1) - #6 AWG -
	Mechanical	(1) 350 Kcmil
250	Al	(1) - #6 AWG -
	Compression	(1) 350 Kcmil
400	Al	(2) - #4 AWG -
	Mechanical	(1) 600 Kcmil

- 200% neutral¹
- Copper lugs, mechanical line and branch neutral¹

- NEMA 3R enclosures
- NEMA 3R/12 enclosures
- NEMA 4 enclosures
- NEMA 4X enclosures
- Special keyed locks
 - TEY
 - TEU1
 - Cat 60
 - LL803
 - LL806
 - Yale
- Panel skirts
- Gaskets between trim and box

- Bus mounted TVSS¹
- Service entrance labeling
- Grounding of Panelboards
Ground Bars except for brazed to box are shipped with the panel interior factory mounted.
 - Non-Insulated Equipment Ground Bar – Standard
 - Copper Non-Insulated Ground Bar
 - Al Insulated Equipment Ground Bar
 - Cu Insulated Equipment Ground Bar
 - Ground Bar Brazed to Box (recommended for painted boxes)
- Shunt Trip on Main or Branch
BL², BLH², HBL², BQD², NGB² as branch use 1" unit space for shunt trip.

QJ2, QJ2-H, QJH2, ED2, ED4, ED6, HED4, HED6, HHED6, FD6, FXD6, HFD6, HFXD6, JXD6, JD6, HJD6, HJXD6, HQJ2H

- Remote control switches – 480V AC max. mounted in a 23" enclosure to be cable connected to the panel.
- Time Clocks – mounted in a 23" enclosure to be cable connected to the panel. Sangamo, Tork or Paragon time clock can be supplied and mounted in panelboard cabinet.

Description

Time Clock (1-or 2-Pole, Single or Double Throw Contacts; 3-Pole Single Throw)

277V Maximum with Plain Dial

Options:

Astronomical Dial

An Omitting Device

Reserve Power or Carryover

Space and Mounting Provisions Only

¹ Do not increase panel or enclosure size

² Accessories on 1" pole breakers (BL, BQD, NGB, ED) will take 1" unit space.

³ External to the panel, supplied in a separate enclosure.

Connector Modifications

Type P1 Panelboards

Compression Lugs

Table P1-19 – Lugs

Style	Amp Rating	Breaker Type	Compression Connectors	Box Height Addition
MLO	250	N/A	(1)#4 AWG - 350 Kcmil	None
	400	N/A	(1) 250-600 Kcmil or (2)#3/0 AWG - 250 Kcmil	
Main Breaker	125	ED4, ED6, HED4	(1)#12-1/0 AWG	Box must be increased to 24" wide
		HHED6, CED6		
	225	QJ2, QJH2, QJ2H	(1)#6 AWG - 350 Kcmil Cu or Al	
	250	FXD6, HFD6, FD6	(1)#6 AWG - 350 Kcmil Cu or Al	

NOTE: Standard compression lugs used for P1 panels are range taking lugs and may require a particular crimping tool to accommodate the range. Consult factory for information.

Enclosure Modifications

NEMA-4 For Type P1
Water Tight, Dust Tight, Steel Enclosure

Table P1-20

Box Height (inches)	Enclosure Size		
	H	W	D
26	26	20	5.75
32	32		
38	38		
44	44		
50	50		
56	56		
62	62		
68	68		
74	74		

Table P1-22 – Additional Enclosure Modifications

Description
Strip Heaters
Humidstat Control
Thermostat Control

NEMA-4X For Type P1
Water Tight, Dust Tight and Corrosion Resistant
(consult plant to verify actual enclosure size)

Table P1-21

Box Height (inches)	Enclosure - Stainless Steel and Steel with Epoxy Coating			Enclosure - Stainless Steel and Steel w/Epoxy Coating ¹		
	H	W	D	H	D	W
26	26	20	5.75	36	30	8
32	32			36	30	8
38	38			48	36	12
44	44			48	36	12
50	50			60	36	12
56	56			60	36	12
62	62			—	—	—
68	68			—	—	—
74	74	—	—	—		

¹ Limited to sizes shown.

Remote Switch Modifications

Table P1-23 – Control Power Transformer

Size	VA Relay
0,1	50
2	75
3	150
4	250

Table P1-25 – Remote Control Switch Modification

Description
Separate Door in Deadfront Over Switch
Auxiliary Contacts (mounted, not wired)
2-Wire Control

Table P1-24 – Applications for a Remote Switch

Switch Type	Modification
920	Mounts in 23" relay cabinet as a main only
911	≤ 150 AMPS mounts in 23" relay cabinet as a main only >150 AMPS not available
LEN	30A mounts in 23" relay cabinet as a main only

Dimensions

Type P1 Panelboards

Type 1 Box

Box is symmetrical

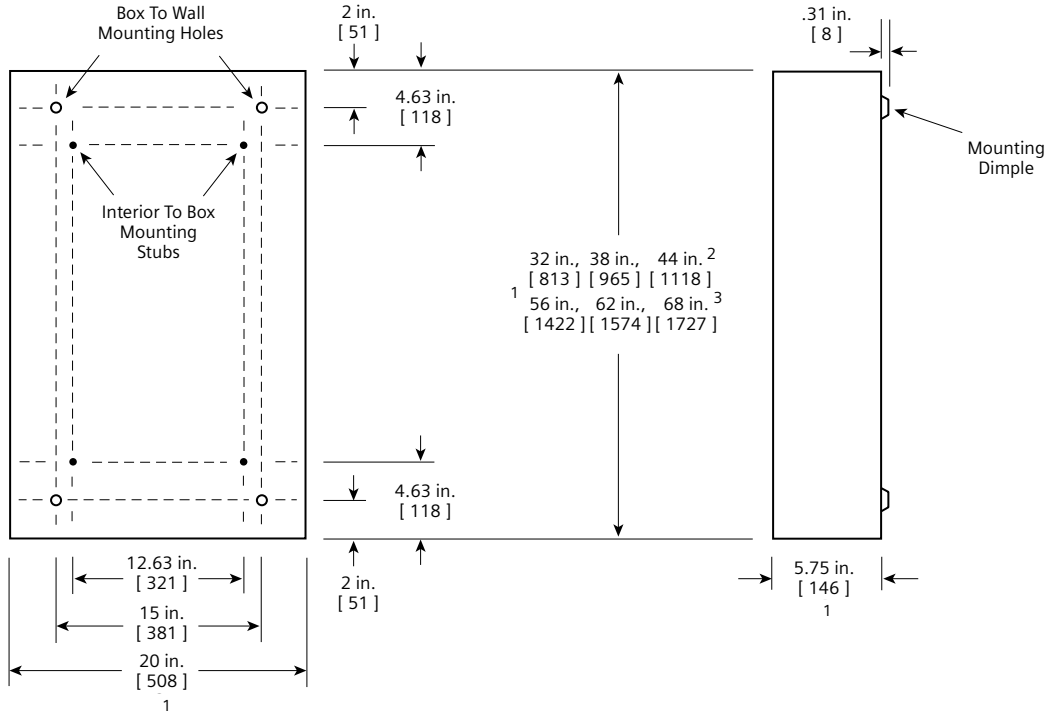

Type 3R and 3R/12 Box

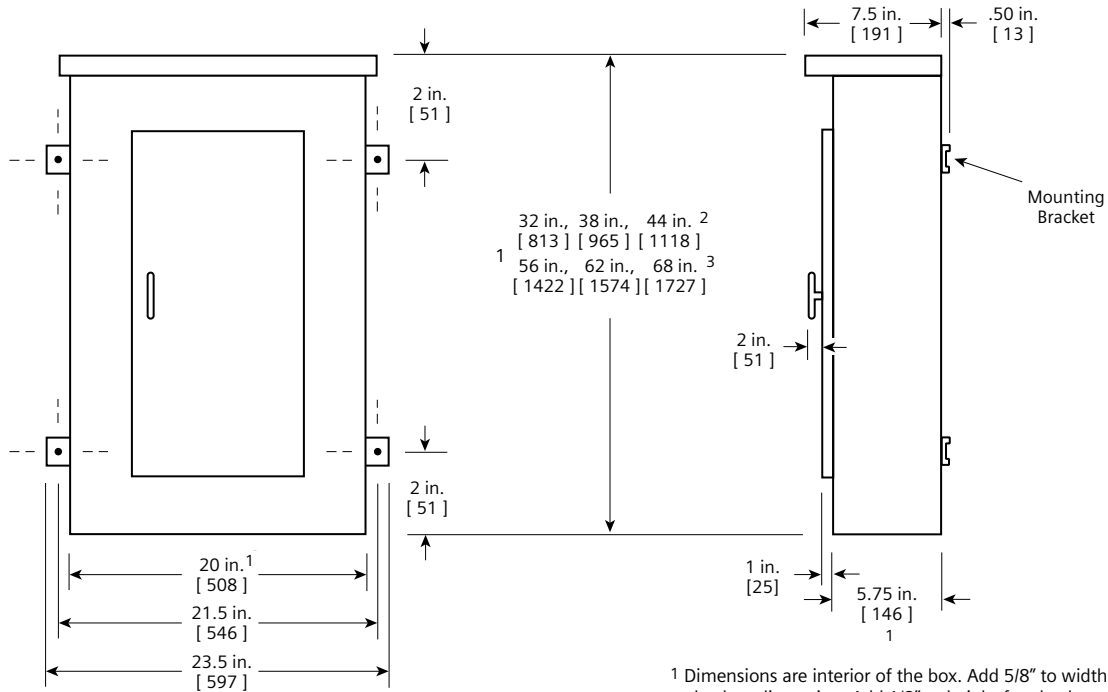

¹ Dimensions are interior of the box. Add 5/8" to width for absolute dimension. Add 1/8" to height for absolute dimension.

² 250 Amp panel.

³ 400 Amp panel.

Dimensions shown in inches and millimeters [].

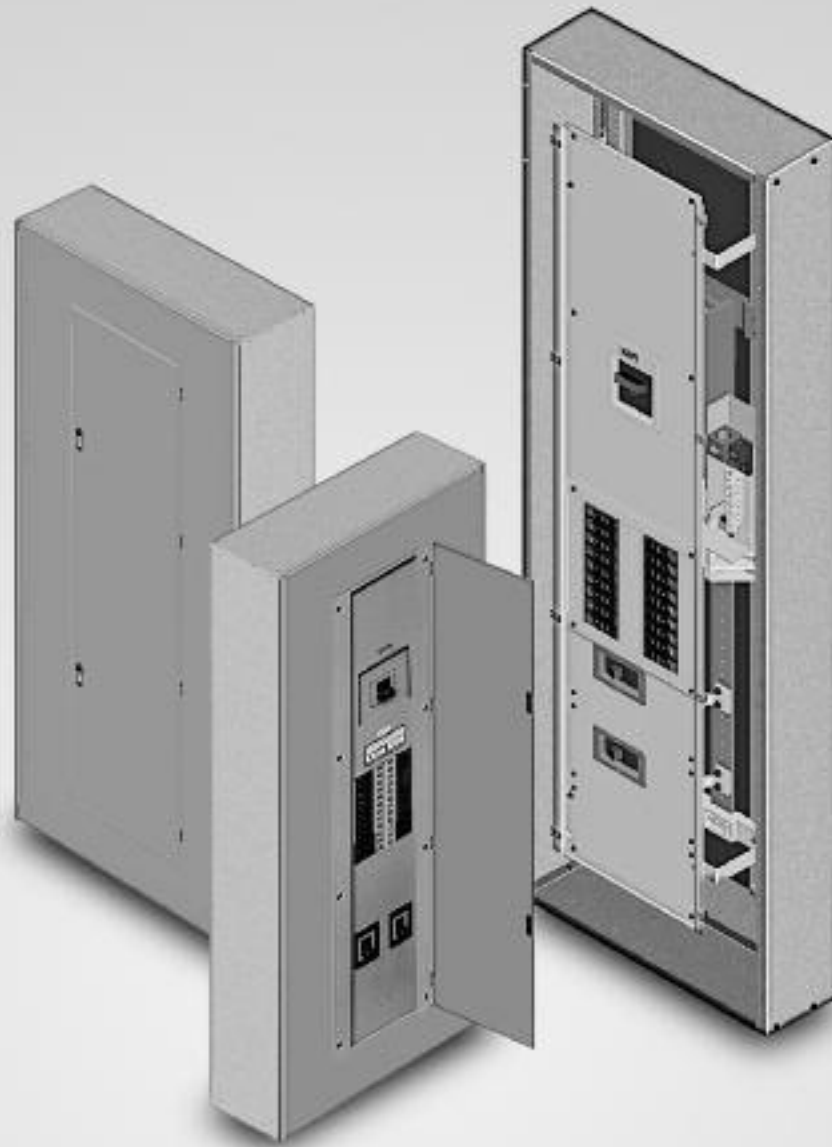

P2 Panelboards

Description	Page		
General Information	2-2	Typical Catalog Numbers	2-6
Selection and Application	2-2	Main Lugs Only	2-6
Application	2-3 – 2-5	Main Circuit Breakers	2-6
Panel Unit Space To Box Height Requirements	2-3	Standard Modifications	2-7
Main Lug Connectors	2-3	Box Size Additions For Optional Features	2-8
Branch Breaker Side Gutters	2-3	Connector Modifications	2-9 – 2-10
Main Breaker Selection	2-4	Compression Lugs	2-9
Subfeed Breakers	2-4	Enclosure Modification	2-10
Branch Circuit Breakers	2-5	Remote Switch Modifications	2-10
Branch Neutral Connections	2-5	Dimensions	2-11
		Kits and Accessories	2-12

P2 Panelboards

Flexibility is the hallmark of the P2 panel. This panel offers a wide array of factory-assembled options to meet virtually any lighting panel application. The ability to mix breaker frames within the unit space up to 225 amps will also meet certain distribution panel requirements in a much smaller package. Bussing options for the P2 vary from a typical temperature rating of 750 A/Si aluminum, to 1000 A/Si copper. Standard bussing in the P2 panel is tin-plated. Silver-plated copper is offered as an option. Integrated time clocks, bus mounted contactors (as mains or sub mains), split bus, and subfeed lugs (up to 400 amps) are just a few of the options available in this unique panel.

As with our other lighting panelboards, the standard P2 panel set up includes 18, 30, 42 or 54 breakers. In specific applications, the panel can accept 66, 78 or 90 circuits. The 6" circuit increments allow the user to configure the smallest possible panel size. The P2 starts with 9" of unit space (18 circuits of 1 pole breakers). Breakers mounted in the unit space can be mixed and matched to meet customer requirements. The 1" pole devices (BL, BOD, NGB, ED) are mounted in 3" or 6" increments. Breaker frames above 125A are single mounted in a 6" space. An example of a minimum panel is as follows: (6) 20A, 1-pole, BL breakers (3" of unit space) and a 225A, 3-pole, QJ breaker (6" of unit space) equaling 9" of unit space can be configured in a P2 panel without any extra provisions or space required. FD 250 and JD 400A breakers are mounted outside the unit space.

Another unique feature of the P2 panel is that blank unit space can be added to allow for future expansion or modifications. All expansion or modifications must be in 3" increments. BL, BQD, NGB, and ED frame breakers have 3" or 6" pole kits, and can be mixed within unit space by these increments. Breakers of the same frame can cross from one mounting to another if contiguous. QJ frame breakers are mounted in 6" increments for two and three pole, single mounted units. Changes in the unit space length for BL, BQD, NGB or ED frame breakers require an addition deadfront, center strip kit. Check with sales or the factory for additional unit space kits.

Selection and Application

Step 1

Determine configuration required.

Example:

Amperage	250A
Voltage	208Y/120V
System	3Ø4W
Main	Main Lug
Bus Material	ASI rated aluminum
Interrupt Rating	10 Ka
Branch Devices	(6) 20 amp, 1-pole (1) 225 amp, 3-pole
Feed Location	Top
Mounting	Surface

Step 2

Create a catalog number by following the Catalog Numbering System on page 6.

Note that the number of circuits number (4th and 5th position) will be 18 for those panels with 6-18 circuits, 30 for those panels with 19-30 circuits, 42 for those panels 31 to 42 circuits and 54 for those panels 43 to 54 circuits. The most cost effective 20 amp 1-pole breaker for this application would be BL. However, a myriad of other breakers with options may be used in the P2 panel. The most cost effective 225 amp breaker for this application is the QJ2.

Check with sales or the factory for other options as we will be adding to our capabilities.

Based on the above
P2C18ML250ATS
(6) BL 20 amp 1-Pole
(1) QJ2 225 amp 3-pole

Step 3

Determine the enclosure size. The matrix on page 2-3 shows the enclosure sizes based on the amperage, main device and unit space required.

Main Lug / Main Breaker

Enclosure – Standard Type 1 enclosure is 20" wide x 5.75" deep X. Box Height is determined by main device and unit space. See charts for box height.

Voltage – 600 Vac Max.
250 Vdc Max.

Amperage – 600 amp Max.

Short circuit rating – 200 KAIC Max. symmetrical or equal to the lowest rated device installed unless a series rating is indicated. Panels with subfeed or feed-thru lugs without a main device, circuit breaker or fusible unit, are limited to a three-cycle rating. The three-cycle rating for the P2 panel is limited to 22 KAIC. Note that the main device may be mounted remote from the panel.

Bussing – The P2 panel has more options to meet market requirements. The standard bussing is temperature rated aluminum. The rating is per the requirements of UL 67 – the standard for panelboards. All aluminum bussing is tin-plated. Optional bussing for the P2 panel is: 750 A/Si aluminum, temperature rated copper, and 1000 A/Si copper. The copper bus option for this panel is tin-plated.

Weight – Approximate

Total panelboard weight when filled with a normal quantity of breakers and accessories is about 3 lbs. (1 kg) per inch (54g per mm) of box height.

**Table P2-1 – Gauge Steel of Boxes
Fronts, Surface and Flush**

Dimensions in inches (mm)		Gauge Steel	
Width	Height	Box	Front
20"	26 - 74	#16	#14
(508)	(660, 1880)		

Application

Type P2 Panelboards

Table P2-2 – Panel Unit Space To Box Height Requirements

"B" Dimension Box Height	P2 Panels With Standard Line Lugs. Unit Space (starting with 9" and adding 6" increments) "A" Dimension															
	Main Lugs				Main Breakers											
	125A	250A	400A	600A	125A Horiz. BL, BQD, NGB, ED	125A Horiz. CED	125A Vert. ED	225A Horiz. QJ	225 Vert. QJ	250A Horiz. FD	250A Vert. FD	250A Vert. CFD	400A Vert. JD	400A Vert. CJD	600A Vert. LD	600A Vert. CLD
26	9	—	—	—	9	—	—	—	—	—	—	—	—	—	—	—
32	15	9	—	—	15	9	9	9	—	—	—	—	—	—	—	—
38	21	15	9	9	21	15	15	15	9	9	—	—	—	—	—	—
44	27	21	15	15	27	21	21	21	15	15	9	—	—	—	—	—
50	33	27	21	21	33	27	27	27	21	21	15	9	9	—	—	—
56	39	33	27	27	39	33	33	33	27	27	21	15	15	—	9	—
62	45	39	33	33	45	39	39	39	33	33	27	21	21	9	15	—
68	—	45	39	39	—	45	45	45	39	39	33	27	27	15	21	15
74	—	—	45	45	—	—	—	—	45	45	39	33	33	21	27	21

Note: When the number of circuits exceeds 54 on a 125 and 250A MLO and 125 and 250A main breaker application, add 6" to the box height.

Table P2-3 – Main Breaker (Fig. P2-1)

Panel Amps	Breaker Frames	C	D
100	BL	5.75	8.00
	BQD	5.125	8.00
125	NGB	4.63	8.00
	ED	4.00	8.00
225	QJ	5.00	7.00
250	FD	5.00	7.00
400	JD	14.00	25.00
600	LD	15.50	23.00

Table P2-4 – Main Lug Connectors (Fig. P2-2)

Panel Amps	Standard Connectors	C	D
125	(1) #14 - 2/0	6.62	8.19
250	(1) #6 AWG - 350 Kcmil	12.34	11.22
400	(1) #4 AWG - 600 Kcmil or (2) #6 - 250 Kcmil	14.00	13.09
600	(2) #4 AWG - 500 Kcmil	14.00	11.00

Fig. P2-1

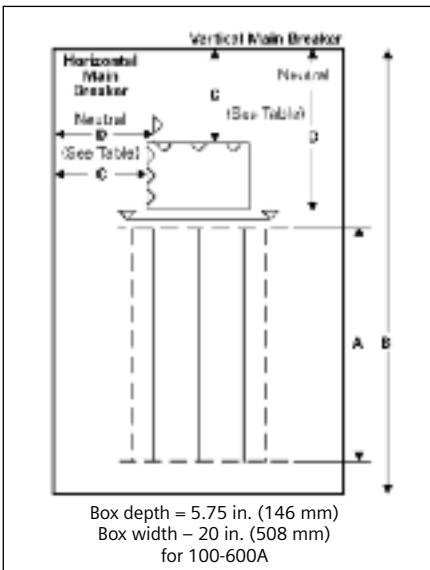

Fig. P2-2

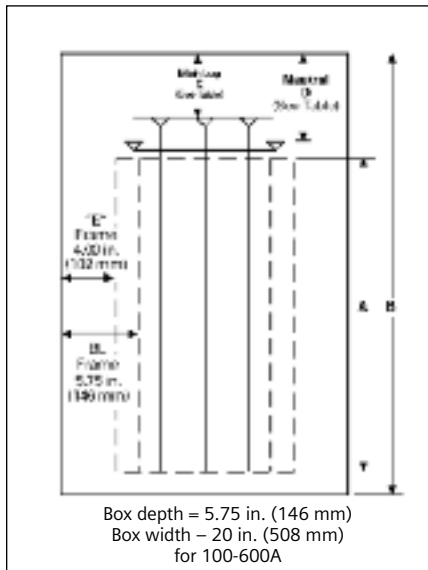
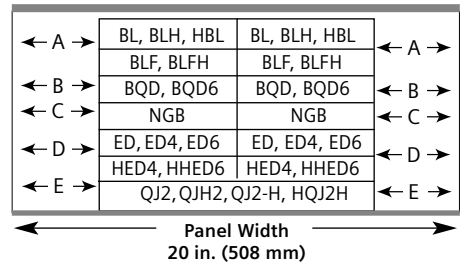

Table P2-5 – Branch Breaker Side Gutters Inches (mm) (Fig. P2-3)

Reference Letter	Panel Width 20" (508)
A	5.750 (146)
B	5.125 (130)
C	4.600 (117)
D	4.000 (102)
E ¹	5.000 (127)

¹ Single branch mounting construction.

Fig. P2-3



Application

Type P2 Panelboards

Table P2-6 – Main Breaker Selection ¹

Ampere Rating	Breaker Type	Maximum Interrupting Rating (kA)			Available Trip Values
		240V	480V	600V	
100	BL (STD)	10	—	—	15, 20, 25, 30, 35, 40, 50, 60, 70, 80, 90, 100
	HBL	65	14	—	
	BQD ²	65	18	—	
	ED4	65	25	—	
	ED6	100	42	18	
	HED4	100	65	—	
	HHED6	100	65	25	
	CED6	200	200	100	
125	ED4 (STD)	65	18	—	125
	ED6	65	25	18	
	NGB	100	25	18	
	HED4	100	42	—	
	HHED6	100	65	25	
	CED6	200	200	100	
225	QJ2 (STD)	10	—	—	60, 70, 80, 90, 100, 110, 125, 150, 175, 200, 225
	QJH2	22	—	—	
	QJ2H	42	—	—	
	HQJ2H	100	—	—	
	FD6, FXD6	65	35	18	70, 80, 90, 100, 110, 125, 150, 175, 200, 225
	HFD6, HFXD6	100	65	25	
	CFD6	200	150	100	
250	FD6, FXD6 (STD)	65	35	18	250
	HFD6, HFXD6	100	65	25	
	CFD6	200	150	100	
400	JXD6 (STD), JD6	65	35	25	200, 225, 250, 300, 350, 400
	HJD6, HJXD6	100	65	35	200, 225, 250, 300, 350, 400
	SJD6	65	35	25	200, 300, 400
	SHJD6	100	65	35	200, 300, 400
	CJD6, SCJD6	200	200	100	200, 300, 400
600	LXD6 (STD)	65	35	25	450, 500, 600
	LD6	65	35	25	250, 300, 350, 400, 450, 500, 600
	HLD6, HLXD6	100	65	35	250, 300, 350, 400, 450, 500, 600
	SLD6	65	35	25	300, 400, 500, 600
	SHLD6 ³	100	65	35	300, 400, 500, 600
	CLD6, SCLD6	200	150	100	300, 400, 500, 600

¹ Interchangeable trip

² For use on 480Y/277 volt systems not suitable for 480 Delta 3 phase, 3 wire systems.

³ Top feed only.

Table P2-7 – Subfeed Breakers

Breaker Type	Mounting Position When Used As Subfeed Breaker	Maximum Interrupting Rating (kA) Symmetrical	240V AC	480V AC	600V DC
	Vertical	Ampere Ratings For Load			
FD6 ¹ , FXD6	Twin/Single	70 - 250	65	35	18
HFD6 ¹ , HFXD6	Twin/Single	70 - 250	100	65	25
JD6 ² , JXD6	Single	200 - 400	65	35	25
HJD6 ² , HJXD6	Single	200 - 400	100	65	35

¹ Twin mounted subfeed breakers are mounted at bottom of panelboard only and adds 24" to the panel height. Single mounted FD subfeed breaker is horizontally mounted and requires 12" additional box height.

² Subfeed breaker is mounted at bottom of panelboard only. 400 amp subfeed breaker adds 30" to the panel height.

Application

Type P2 Panelboards

Table P2-8 – Branch Circuit Breakers

Max. Amp Rating	Bolt-On Breaker Type	No. of Poles	Amp Rating	Maximum Interrupting Rating (kA)						
				Volts – AC						DC
				120	120/240	240	277	480	600	
100	BL	1	15 - 70	10	—	—	—	—	—	—
		2	15 - 100	—	10	—	—	—	—	—
		3	15 - 100	—	—	10	—	—	—	—
	BL, HID	1	15 - 30	10	—	—	—	—	—	—
		2	15 - 30	—	10	—	—	—	—	—
	BLR	2	15 - 100	—	—	10	—	—	—	—
	BLE	1	15 - 30	10	—	—	—	—	—	—
		2	15 - 60	—	10	—	—	—	—	—
	BLEH	1	15 - 30	22	—	—	—	—	—	—
		2	15 - 60	—	22	—	—	—	—	—
	BLF	1	15 - 30	10	—	—	—	—	—	—
		2	15 - 60	—	10	—	—	—	—	—
	BLHF	1	15 - 30	22	—	—	—	—	—	—
		3	15 - 60	—	22	—	—	—	—	—
		2	15 - 30	10	—	—	—	—	—	—
	BGL ¹	3	15 - 30	—	10	—	—	—	—	—
		1	15, 20	10	—	—	—	—	—	—
	BAFH	1	15, 20	22	—	—	—	—	—	—
	BLH	1	15 - 70	—	22	—	—	—	—	—
		2	15 - 100	—	22	—	—	—	—	—
3		15 - 100	—	—	22	—	—	—	—	
HBL	1	15 - 70	—	65	—	—	—	—	—	
	2	15 - 100	—	65	—	—	—	—	—	
	3	15 - 100	—	—	65	—	—	—	—	
BQD	1	—	—	65	—	14	—	—	14	
	2	15 - 100	—	65	—	—	14	—	14	
	3	—	—	—	65	—	14	—	14	
125	NGB	1	—	100	—	—	25	—	—	14
		2/3	15 - 125	—	100	100	—	25 ²	—	—
	ED4	1	15 - 125	65	—	—	22	—	—	—
		2	—	—	—	65	—	18	—	30
		3	—	—	—	65	—	18	—	—
	ED6	2	15 - 125	—	—	65	—	25	18	30
		3	—	—	—	65	—	25	18	—
	HED4 HHED6	1	—	100	—	—	—	—	—	—
		2	15 - 125	—	—	—	65	—	—	—
		3	—	—	—	—	100	42	42	—
QJ2	2/3	60 - 225	—	—	10	—	—	—	—	
QJH2	2/3	60 - 225	—	—	22	—	—	—	—	
QJ2-H	2/3	60 - 225	—	—	42	—	—	—	—	
HQJ2H	2/3	100 - 225	—	—	100	—	—	—	—	

¹ Two pole breaker is one phase and neutral. Three pole is two phase and neutral.

² For use on 480Y/277 volt systems. Not suitable for 480 delta, 3-phase, 3-wire systems.

NOTE: QJ Breakers are single mounted in unit space and take 6" of unit space. Limited to (4) per panel max. BL, HBL, BLH, NGB and BQD breakers are mounted in common mountings in 3" or (6) pole increments. ED4, ED6, HED4 and HHED6 breakers are mounted in common mountings in 3" or (6) pole increments.

Branch Device Limitations

In areas where 2008 NEC has not been adopted, some limitations may apply for panels used in systems requiring neutral connections. By application rule (480.14 in all versions of the NEC prior to 2008), lighting and appliance panels are limited to 42 installed circuits. Each over current device pole counts as a circuit.

Table P2-9 – Branch Neutral Connections

Wire Range	Max. Number of Connections	Max. Amps ¹
#14-#6	48	65
#14-1/0	56	125
#6 - 350 Kcmil	4	250
(1) #4-600 Kcmil or (2) #6-250 Kcmil	1	400

¹ Based on 75 degree copper.

Typical Catalog Numbers

Type P2 Panelboards

Table P2-10 – Main Lugs Only

Maximum Panel Amp Rating	Maximum 1-Pole Circuits	Box Height inches (mm)	Catalog Number		
			3Ø4W 208Y/120V	1Ø3W 120/240V	3Ø4W 480Y/27V
125	18	26 (660)	P2C18ML125ATS	P2A18ML125ATS	P2E18ML125ATS
	30	32 (813)	P2C30ML125ATS	P2A30ML125ATS	P2E30ML125ATS
	42	38 (965)	P2C42ML125ATS	P2A42ML125ATS	P2E42ML125ATS
250	18	32 (813)	P2C18ML250ATS	P2A18ML250ATS	P2E18ML250ATS
	30	38 (965)	P2C30ML250ATS	P2A30ML250ATS	P2E30ML250ATS
	42	44 (1118)	P2C42ML250ATS	P2A42ML250ATS	P2E42ML250ATS
400	18	38 (965)	P2C18ML400ATS	P2A18ML400ATS	P2E18ML400ATS
	30	44 (1118)	P2C30ML400ATS	P2A30ML400ATS	P2E30ML400ATS
	42	50 (1270)	P2C42ML400ATS	P2A42ML400ATS	P2E42ML400ATS
600	18	38 (965)	P2C18ML600ATS	P2A18ML600ATS	P2E18ML600ATS
	30	44 (1118)	P2C30ML600ATS	P2A30ML600ATS	P2E30ML600ATS
	42	50 (1270)	P2C42ML600ATS	P2A42ML600ATS	P2E42ML600ATS

Table P2-11 – Main Circuit Breaker

100	18	26 (660)	P2C18BL100ATS	P2A18BL100ATS	P2E18BD100ATS
	30	32 (813)	P2C30BL100ATS	P2A30BL100ATS	P2E30BD100ATS
	42	38 (965)	P2C42BL100ATS	P2A42BL100ATS	P2E42BD100ATS
125	18	26 (660)	P2C18NB125ATS	P2A18NB125ATS	P2E18NB125ATS
	30	32 (813)	P2C30NB125ATS	P2A30NB125ATS	P2E30NB125ATS
	42	38 (965)	P2C42NB125ATS	P2A42NB125ATS	P2E42NB125ATS
225	18	32 (813)	P2C18QJ225ATS	P2A18QJ225ATS	P2E18FX225ATS
	30	38 (965)	P2C30QJ225ATS	P2A30QJ225ATS	P2E30FX225ATS
	42	44 (1118)	P2C42QJ225ATS	P2A42QJ225ATS	P2E42FX225ATS
250	18	38 (965)	P2C18FX250ATS	P2A18FX250ATS	P2E18FX250ATS
	30	44 (1118)	P2C30FX250ATS	P2A30FX250ATS	P2E30FX250ATS
	42	50 (1270)	P2C42FX250ATS	P2A42FX250ATS	P2E42FX250ATS
400	18	50 (1270)	P2C18JX400ATS	P2A18JX400ATS	P2E18JX400ATS
	30	56 (1422)	P2C30JX400ATS	P2A30JX400ATS	P2E30JX400ATS
	42	62 (1575)	P2C42JX400ATS	P2A42JX400ATS	P2E42JX400ATS
600	18	56 (1422)	P2C18LX600ATS	P2A18LX600ATS	P2E18LX600ATS
	30	62 (1575)	P2C30LX600ATS	P2A30LX600ATS	P2E30LX600ATS
	42	68 (1727)	P2C42LX600ATS	P2A42LX600ATS	P2E42LX600ATS

Standard Modifications

Type P2 Panelboards

P2 Panel Options

Enclosures

- Extra gutter to sides or ends of the can
- 24" wide boxes
- Hinged trims
- Door-in-door trims
- Screw to the box trims
- Trim mounted devices (Devices mounted and wired to the trim should also have hinged trim specified)
 - Pilot lights
 - Toggle switches
 - Push buttons
- Painted boxes
- Custom colors
- Increase gauge trims and boxes
- Stainless steel trims and boxes, Type 1
- Aluminum trims and boxes, Type 1
- NEMA 3R enclosures
- NEMA 3R/12 enclosures
- NEMA 4 enclosures
- NEMA 4X enclosures
- Special keyed locks
 - TEY
 - TEU1
 - Cat 60
 - LL803
 - LL806
 - Yale
- Gasketing trim to box
- Meters (Contact application engineering for space requirements)
- Panel Skirts

Panel Modifications

- Main Bus
Standard main bus is temperature rated tin-plated aluminum. Bus options are 750 A/Si aluminum, tin-plated temperature rated copper tin-plated standard – silver optional. 1000 A/Si copper tin-plated standard – silver optional. Includes copper neutral cross bar. For copper neutral branch lugs, see miscellaneous.
- Split bus adds 6" to unit space
- Compression lug for MLO
- Compression lugs on Main breaker (may require extra width or length on enclosure).
- Contactor mains or submain
 - Asco 920 through 225 amps. Adds 12" unit space as main, 15" unit space as submain.
 - Asco 911 through 150 amps. Adds 21" unit space.
 - Siemens LEN through 30 amps. Adds 12" unit space. Makes box 10" deep.
- Control power transformers (contact engineering for extra gutter requirements)
- Branch and main breaker accessories
 - Handle blocks
 - Handle locks
 - Aux. Contacts¹
 - UVR¹
- Feed-thru lugs
- 200% neutral
- Copper lugs, mechanical
- Bus mounted TVSS
- Service entrance labeled
Type P2 Panelboards are factory labeled suitable for use as service entrance equipment when NEC requirements are met. A panelboard cannot have more than six main disconnects, unless it is a lighting and appliance branch panelboard. Lighting and appliance branch panelboards are limited to two main disconnects.
- Grounding of panelboards
Ground Bars, except brazed-to-box, are shipped with the panel interior factory mounted.
 - Non-Insulated Equipment Ground Bar – Standard
 - Copper Non-Insulated Ground Bar
 - Al Insulated Equipment Ground Bar
 - Cu Insulated Equipment Ground Bar
 - Ground Bar Brazed to Box (recommended for painted boxes)
- Shunt Trip on Main or Branch
BL, BLH, HBL, ED2, ED4, HED4, HED6, HHED6 uses 1" unit space for shunt trip. All may be used on mains or subfeeds.

QJ2, QJ2-H, QJH2, HQJ2H, ED2, ED4, ED6, HED4, HED6, HHED6, FXD6, HFD6, JXD6, JD6, HJD6, HJXD6, HQJ2H
--
- Remote control switches – 480V AC max. mounted in a 23" enclosure to be cable connected to the panel.
- Time Clocks – mounted in a 23" enclosure to be cable connected to the panel. Sangamo, Tork or Paragon time clock can be supplied and mounted in panelboard cabinet.

Description
Time Clock (1-or 2-Pole, Single or Double Throw Contacts; 3-Pole Single Throw)
277V Maximum with Plain Dial
Options –
Astronomical Dial
An Omitting Device
Reserve Power or Carryover
Space and Mounting Provisions Only

¹ Accessories on 1" pole breakers (BL, BQD, ED) will take unit space

Standard Modifications

Type P2 Panelboards

Table P2-12 – Box Size Additions (In.) For Optional Features on MLO Applications

Optional Features	MLO – Standard Lugs				MLO – Copper Only Lugs				MLO – Compression Lugs			
	125	250	400	600	125	250	400	600	125	250	400	600
Min. Box Size ¹	26	32	38	38	32	38	44	38	32	38	44	44
Sub-Feed lugs	0	6	6	N/A	N/A	N/A	N/A	N/A	N/A	N/A	N/A	N/A
Feed Thru Lugs	6	6	12	12	6	6	12	N/A	6	12	N/A	N/A
(1) 1FD sub-feed Bkr.	N/A	12	12	12	N/A	12	12	12	N/A	12	12	12
(2) FD sub-feed Bkrs.	N/A	24	24	24	N/A	24	24	24	N/A	24	24	24
(1) JD sub-feed Bkr.	N/A	N/A	24	24	N/A	N/A	24	24	N/A	N/A	24	24
TVSS	12	12	12	12	12	12	12	12	12	12	12	12
200% Neutral	0	0	6	6	0	0	0	N/A	0	0	0 ⁴	N/A
200% Neutral w/Feed Thru Lugs	N/A	N/A	N/A	N/A	N/A	N/A	N/A	N/A	N/A	N/A	N/A	N/A
Split Bus	12 ²	12 ²	18 ³	18 ³	18 ²	18 ³	24 ³	24 ³	18 ²	18 ³	24 ³	24 ³

¹ Based on 9" of unit space.

² Based on 9" of upper unit space and 6" of lower unit space.

³ Based on 6" of upper unit space and 6" of lower unit space.

⁴ 200% neutral is not available when the panel is supplied by (2) cables in lieu of (1).

Table P2-13 – Box Size Additions (In.) For Optional Features on Main Breaker Applications

Optional Features	Main Breaker – Horizontal Mounting					Main Breaker – Vertical Mounting							
	100A BL, BQD	125A NGB, ED	125A CED	225A QJ	250A FD	125A ED	225A QJ	250A FD	250A CFD	400A JD	400A CJD	600A LD	600A CLD
Min. Box Size ¹	26	26	32	32	38	32	38	44	50	50	62	56	62
CopperLugs	N/A	N/A	N/A	N/A	N/A	0	0	0	0	0	0	0	0
Compression Lugs	N/A	N/A	N/A	N/A	N/A	0	0	0	0	0	0	0	0
Feed Thru Lugs	6	6	6	N/A	N/A	6	6	6	6	12 ²	12 ³	12 ³	12 ³
(1) FD sub-feed Bkr.	N/A	N/A	N/A	N/A	12	N/A	N/A	12	12	12	12	12	12
(2) FD sub-feed Bkr.	N/A	N/A	N/A	N/A	24	N/A	N/A	24	24	24	N/A	N/A	N/A
(1) JD sub-feed Bkr.	N/A	N/A	N/A	N/A	N/A	N/A	N/A	N/A	N/A	24	N/A	N/A	N/A
TVSS	12	12	12	12	12	12	12	12	12	12	12	12	12
200% Neutral	0	0	0	N/A	N/A	0	0	0	0	0 ²	0 ²	0 ³	0 ³
200% Neutral w/ Feed Thru Lugs	N/A	N/A	N/A	N/A	N/A	N/A	N/A	N/A	N/A	N/A	N/A	N/A	N/A

¹ Based on 9" of unit space.

² This feature is not available when the panel is supplied by (2) cables in lieu of (1).

³ Not available with copper or compression lugs.

The definition and reference to lighting and appliance panelboards and power panelboards was removed from the 2008 NEC. This change removed the basic 42 circuit limitation for lighting and appliance panelboards. The NEC still has a 42 circuit limitation for special applications referred to in 408.36 Exception 2 and 645.17. As a result, of this change, the panel capability has been expanded to support up to 90 circuits.

In some cases, this expanded capability will require an extra 6" of box height. See the chart below.

MLO - 125A

MLO - 250A

MB -100A

MB -125A

MB - 250A

Connector Modifications

Type P2 Panelboards

Compression Lugs

Table P2-14 – Lugs

Style	Amp Rating	Breaker Type	Compression Connectors	Box Height Addition
MLO	125	N/A	(1) #6 - 350KCMIL Al/Cu	6
	250	N/A	(1) #6 - 350KCMIL Al/Cu	6
	400	N/A	(1) 500 - 750KCMIL Al (1) 500KCMIL Cu (2) #6 - 350KCMIL Al/Cu	6 6 6
	600	N/A	(2) #6 - 350KCMIL Cu (2) 500 - 750KCMIL Al	6 6
Main Breaker	125	ED4, ED6, HED4 HHED6, CED6	(1) #14-2/0 AWG Al/Cu	ED4, ED6, HED4, HHED6 are vertically mounted and require a 6" increase in box height Box must go to 24"W for CED6 breaker and an additional 6" of box height is required for neutral)
	225	QJ2, QJH2, QJ2H, HQJ2H	(1) #6 - 350KCMIL Al/Cu	The breaker is vertically mounted only. Add 6" to the box height
	250	FD6, FXD6, HFD6, HFXD	(1) #6 - 350KCMIL Al/Cu	This breaker is vertically mounted only. Add 6" to the box height
		CFD	(1) #6 - 350KCMIL Al/Cu	—
	400	JD6, JXD6, HJD6, HJXD6, HQJ2H	(1) #3/0 - 600KCMIL Cu (2) #3/0 - 500KCMIL Al	—
		SJD6, SHJD6 CJD6, SCJD6	(1) 500 - 750KCMIL Al	—
	600	LD6, LXD6, HLD6, HLXD6	(1) #3/0 - 600KCMIL Cu (2) #3/0 - 500KCMIL Al	—
SLD6, SHLD6 CLD6, SCLD6		(1) 500 - 750KCMIL Al	—	

Connector Modifications

Type P2 Panelboards

Enclosure Modifications

Enclosure Modification NEMA 4 for Type P2 Water Tight and Dust Tight, Steel Enclosure (consult plant to verify enclosure size)

Table P2-15

Box Height Inches	Enclosure Size		
	H	W	D
26	26	20	5.75
32	32		
38	38		
44	44		
50	50		
56	56		
62	62		
68	68		
74	74		

NEMA-4X For Type P2 Water Tight, Dust Tight and Corrosion Resistant (consult plant to verify enclosure size)

Table P2-16

Box Height Inches	Enclosure - Stainless Steel and Steel with Epoxy Coating			Enclosure - Stainless Steel and Steel with Epoxy Coating ¹		
	H	W	D	H	W	D
26	26	20	5.75	36	30	8
32	32			36	30	8
38	38			48	36	12
44	44			48	36	12
50	50			60	36	12
56	56			60	36	12
62	62			—	—	—
68	68			—	—	—
74	74			—	—	—

¹ Limited to the sizes shown.

Remote Switch Modifications

Table P2-17 – Control Power Transformer

Size	VA
0,1	50
2	75
3	150
4	250

Table P2-18 – Applications for a Remote Switch

Switch Type	Modification
ASCO 920	30 to 225A – Add 12" to MLO box height
ASCO 911 ¹	≤ 225A – Add 21" to the box height. >225A is not available in P2
LEN	60A to 100A adds 6" to the box height with a min. depth of 7.75" 200A adds 6" to the box height with a min. depth of 10.00"

¹ >225A is recommended for use in a P4 panel.

Table P2-19 – Remote Control Switch Modification

Description
Auxiliary Contacts (mounted not wired)
Ea. 2-Wire Control

Dimensions

Type P2 Panelboards

Type 1 Box

Box is symmetrical

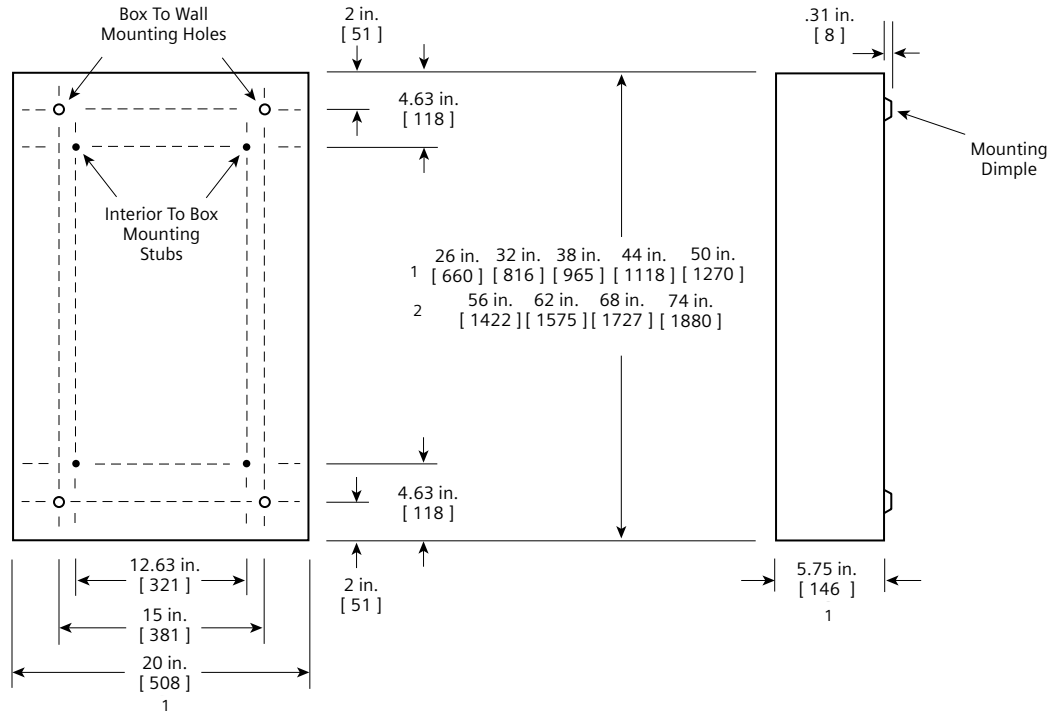

Type 3R and 3R/12 Box

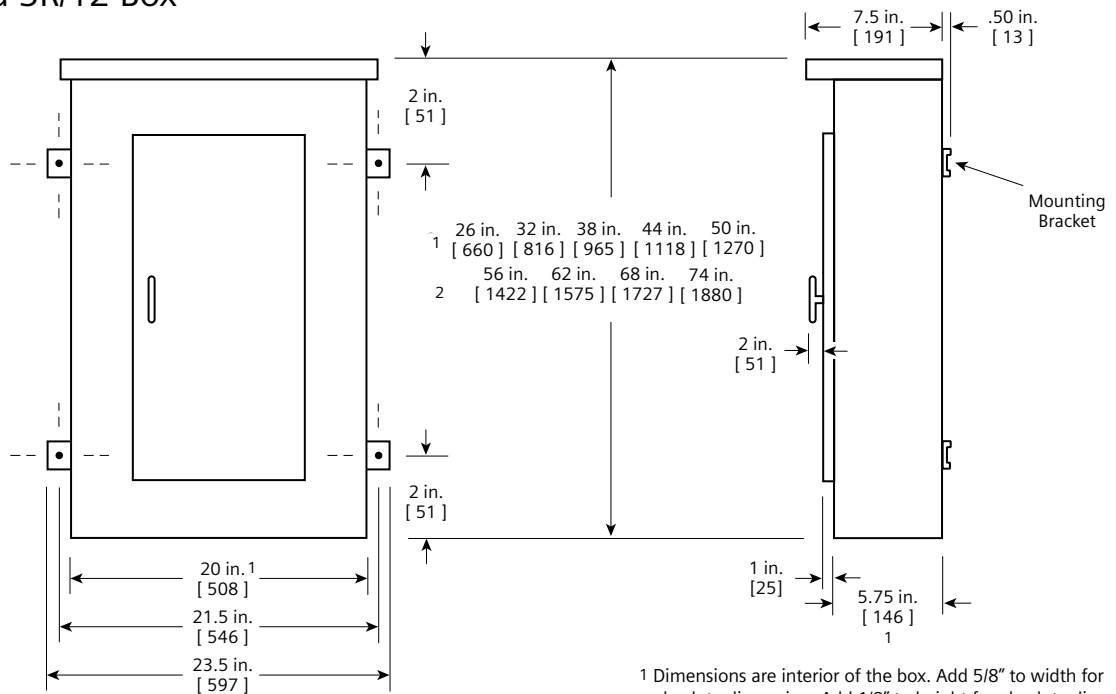

¹ Dimensions are interior of the box. Add 5/8" to width for absolute dimension. Add 1/8" to height for absolute dimension.
² See table P2-12 to match ratings with height.

Dimensions shown in inches and millimeters [].

Kits and Accessories

Type P2 Panelboards

Table P2-20 – Standard Enclosures

Box Height Inches	Catalog Number				
	Type 1 Standard Trim			Type 3R	Type 3R/12
	Box	Surface	Flush		
26	B26	S26B	F26B	NR26	WP26
32	B32	S32B	F32B	NR32	WP32
38	B38	S38B	F38B	NR38	WP38
44	B44	S44B	F44B	NR44	WP44
50	B50	S50B	F50B	NR50	WP50
56	B56	S56B	F56B	NR56	WP56
62	B62	S62B	F62B	NR62	WP62
68	B68	S68B	F68B	NR68	WP68
74	B74	S74B	F74B	NR74	WP74

Options For Type 1 Trims

Hinged trim – Replace “B” suffix with “H”

Door-in-door – Replace “B” suffix with “D”

Metal card holder – Replace “B” suffix with “M” on standard trim, add “M” suffix on optional trims

Option For 24” Wide Enclosures with Equal Gutter on Both Sides

24” wide with equal gutter on both sides - Add “24” as prefix

Table P2-21 – Breaker Kits and Accessories

Kit No.	Description	Contents
BBKB32	BL/BQD 6-pole 3” branch breaker kit	Kit contains top barrier, (3) A/C connectors, (1) B connector, hardware
BBKNB32	NGB 6-pole 3” branch breaker kit	Kit contains breaker support, interphase barriers, (3) A/C connectors, (1) B-phase connector, hardware
BBKED32	ED 6-pole 3” branch breaker kit	Kit contains breaker support, inter-phase barriers, (3) A/C connectors, (1) B-phase connector, hardware
BBKQ1	QJ branch breaker kit for 2 and 3-pole single mount	Kit to contain all connectors and cover plates necessary to mount both 2 and 3-pole breakers
DFK1	BL, BQD, ED deadfront kit for 1” pole breakers	Center strips 3”, 6”, 9”, 15”, 21” plus mounting hardware
DFFP3	Deadfront filler 3”	3” empty space filler and hardware
DFFP6	Deadfront filler 6”	6” empty space filler and hardware
BNK2	Branch neutral (P2)	Three tier lug with mounting hardware to increase neutral capacity
P2BK1	P2 250A max. Bonding Kit	Bonding strap and hardware
P2BK2	P2 400A max. Bonding Kit	Bonding strap and hardware
P2BK3	P2 600A max. Bonding Kit	Bonding strap and hardware

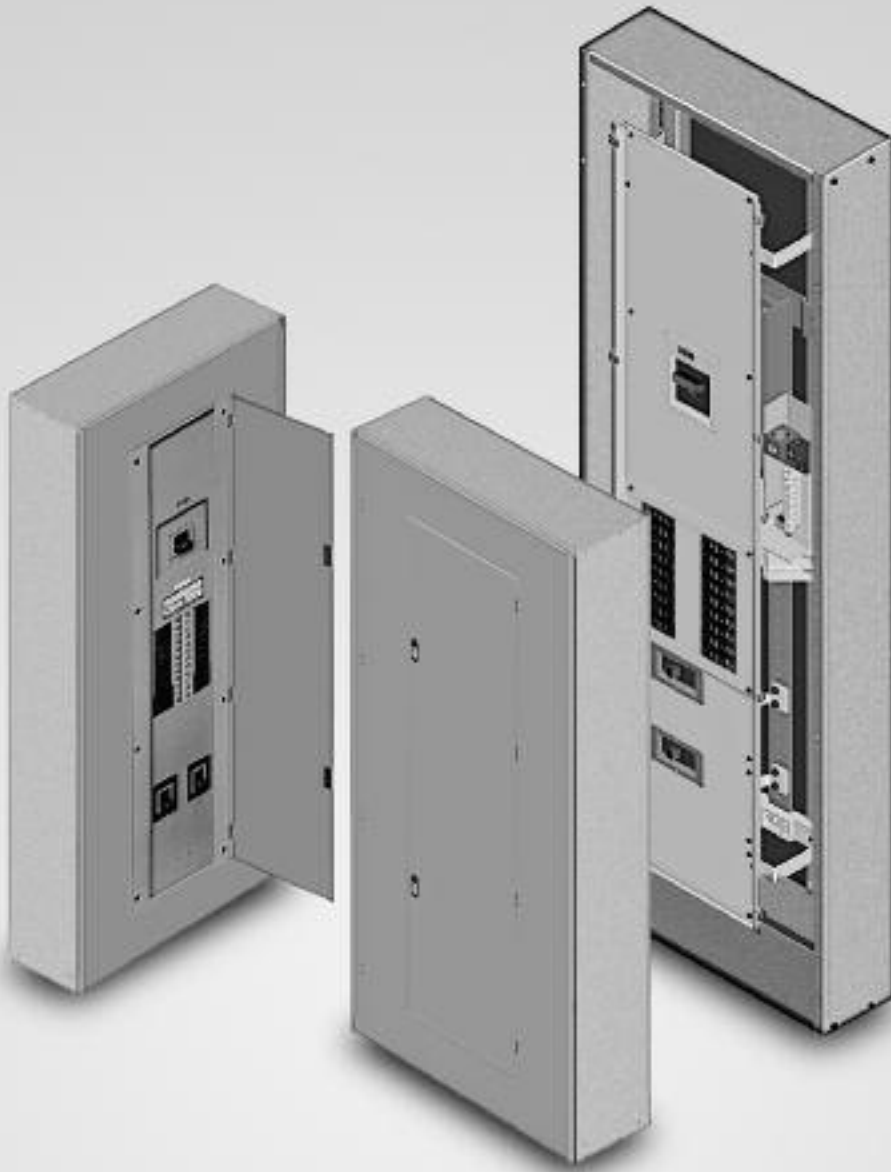

P3 Panelboards

Description	Page		
General Information	3-2	Typical Catalog Numbers	3-6 – 3-7
Selection and Application	3-2	Main Lugs	3-6
Application	3-3 – 3-5	Main Circuit Breakers	3-7
Panel Unit Space to Box Height Requirements	3-3	Standard Modifications	3-8 – 3-9
Main Breaker and Main Lug Wire Bending	3-3	Option Combinations	3-9
Branch Breaker Side Gutters	3-3	Connector Modifications	3-10
Main Lug and Main Breaker		Compression Lugs	3-10
Unit Space Dimensions	3-3	Enclosure Modifications	3-10
Main Breaker Selection	3-4	Remote Switch Modifications	3-10
Subfeed Breakers	3-4	Dimensions	3-11
Neutral Connectors	3-4	Kits and Accessories	3-12
Branch Circuit Breakers	3-5		

Type P3 Panelboards

The innovative P3 panelboard from Siemens is a smaller footprint distribution panel designed for applications that require more large-branch devices than typical lighting panels can support. This panel offers a wide array of factory-assembled options and has the ability to mix breaker frames in unit space up to 225 amps. Bussing options include standard, temperature-rated aluminum and temperature rated (750 ASI¹ and 1,000 AISq") copper. All aluminum bussing in the P3 panel is tin-plated as a standard. Silver-plating is the default for copper bus with tin as an option. Integrated time clocks, bus mounted contactors as mains or sub-mains, split bus and sub-feed lugs (up to 400 amps) are just a few of the options available in this unique panel.

The panel configurations, defined by unit space, allow for given amperage, main device, and box height. The P3 panel starts with a 56" high box. Breakers in unit space can be mixed and matched to meet customer requirements. All 1"pole breakers (BI, BOD, NGB, NEB, HEB and ED frames) are mounted in 3" or 6-pole increments. Breaker frames, rated 225 amps, are dual mounted in 6" increments in unit space. Also available are one or two 250 amp frame breakers or one 400 amp frame breaker, mounted as sub-feed devices outside the unit space.

Like other distribution panels, the P3 panel can include blank space for future expansion or modifications. Any expansions or modifications must be in 3" increments. BL, BQD, NGB, NEB, HEB, and ED frame breakers have 3" or 6-pole kits and can be mixed in unit space by these increments. Breakers of the same frame can cross from one mounting to another if contiguous. QJ frame breakers are mounted in 6" increments for two and three pole single and twin mounted units. Changes in the unit space length for BI, BQD, NGB, NEB, HEB, and ED frame breakers require an additional deadfront center strip kit. Contact your Siemens representative for additional unit space kits.

Selection and Application

- 1) To specify a particular panelboard, first determine voltage, system, amperage and type main, amperage and type of branch devices, and modifications, if any. (Step 1)
- 2) List branch devices and modifications requiring space additions. List unit space requirements of each.

Note: Some units are twin mounted meaning two breakers occupy the same unit space.

Step #1	
Amperage	400
Voltage	208Y/120
System	3 Phase, 4 wire
Main	Main Lug
Bus	Standard Aluminum
Branches	6-20A/13, 2-225/3,
Modifications	None
Feed	Top
Mounting	Surface

Step #2	
6-20A/3	3x3" = 6 poles = 9"
2-225/3 QJ2	6" = $\frac{6"}{15"}$
Enclosure is 56" from Table P3-2 (24" wide, 56" high, 7.75" deep).	

Step #3
Panel - P3C56ML400ATS
Box - 24WD56
Trim - P3S56

Main Lug / Main Breaker

Enclosure – Standard Type 1 enclosure is 24" wide x 7.75" deep. X Box Height is determined by main device and unit space. See charts for box height.

Voltage – 600 Vac Max.
250 Vdc Max.

Amperage – 800 amp Max.

Short Circuit Rating – 200 KAIC Max. symmetrical or equal to the lowest rated device installed unless a series rating is indicated. Panels with subfeed or feed-thru lugs without a main device, circuit breaker or fusible unit, are limited to a three-cycle rating. The three-cycle rating for the P3 panel is limited to 22 KAIC. Note that the main device may be mounted remote from the panel.

Bussing – The P3 panel has more options to meet market requirements. The standard bussing is temperature rated aluminum. The rating is per the requirements of UL 67 – the standard for panelboards. All aluminum bussing is tin-plated. Optional bussing for the P3 panel is: 750 A/si aluminum, temperature rated copper, and 1000 A/si copper. The copper bus option for this panel is tin-plated.

Weight – Approximate

Total panelboard weight when filled with a normal quantity of breakers and accessories is about 5 lbs. (1 kg) per inch (54g per mm) of box height.

Table P3-1 – Gauge Steel of Boxes Fronts, Surface & Flush

Dimensions in inches (mm)		Gauge Steel	
Width	Height	Box	Front
24" (610)	56 - 80 (1422, 2032)	#16	#14

¹ ASI = Amperes per square inch

Select appropriate enclosure height from selection chart on page 3-3, based on unit space requirements. (Step 2)

3) Select panelboard catalog number from appropriate table based upon voltage, system, amperage and unit space requirements. (Step 3)

Application

Type P3 Panelboards

Table P3-2 – Panel Unit Space To Box Height Requirements

"B" Dimension Box Height	P3 Panels With Standard Line Lugs. Unit Space (starting with 9" and adding 6" increments) "A" Dimension											
	Main Lugs					Main Breakers						
	250A	400A	600A	800A with 2-600 Kcmil	800A with 3-500 Kcmil	250A Horizontal FD	250A Vertical FD	250A Vertical CFD	400A Vertical JD	400A Vertical CJD	600A Vertical LD	600A Vertical CLD
56	27	21	21	21	15	21	15	9	9	—	9	—
62	33	27	27	27	21	27	21	15	15	9	15	9
33	39	33	33	33	27	33	27	21	21	15	21	15
74	45	39	39	39	33	39	33	27	27	21	27	21
80	—	45	45	45	39	45	39	33	33	27	33	27

Table P3-3 – Main Breaker Wire Bending (Fig. P3-1)

Breaker Frame	C	E	F
FD Horiz.	7.25	—	20.13
FD Vert.	—	12.25	25.38
CFD	—	13.63	31.38
JD	—	15.63	29.38
CJD	—	14.75	35.38
LD	—	14.75	29.38
CLD	—	14.00	35.38

Table P3-4 – Main Lug Wire Bending (Fig. P3-2)

Panel Amps	Standard Connectors	C	D
250	(1) #6 AWG - 350KCMIL	10.75 ¹	13.50
400	(2) #3/0 AWG - 250KCMIL or (1) #3/0 600KCMIL	16.00	17.88
600	(2) #3/0 AWG - 500KCMIL or	16.00	17.88
800	(2) #3/0 - 600KCMIL	16.00	17.88
800	(3) #3/0 AWG - 500KCMIL	17.50	23.88

¹ This lug is classified as removable.

Fig. P3-1

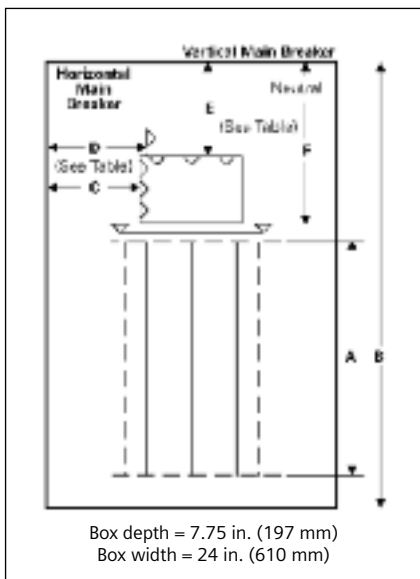

Table P3-5 – Branch Breaker Side Gutters Inches (mm) (Fig. P3-3)

Reference Letter	Panel Width 24" (609)
A	7.750 (197)
B	7.125 (181)
C	6.000 (152)
D	7.000 (178)
E	5.000 (127)
F	7.000 (178)

Fig. P3-3

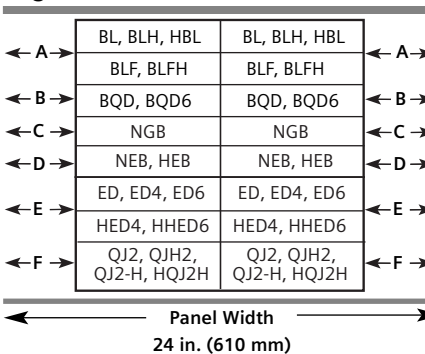

Fig. P3-2

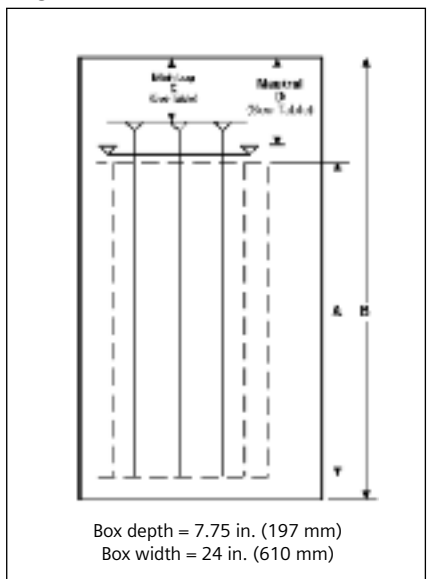

Table P3-6 – Subfeed Breaker Wire Bending (Fig. P3-1)

Breaker Family	Reference Dimensions		
	C	E	F
FD Single	7.25	—	8.25
Dual FD	—	15.25	8.25
Single JD	8.00	—	29.38

Application

Type P3 Panelboards

Table P3-7 – Main Breaker Selection¹

Ampere Rating	Breaker Type	Maximum Interrupting Rating (kA)			Available Trip Values
		240V	480V	600V	
250	FD	65	35	18	70, 80, 90, 100, 110, 125, 150, 200, 225, 250
	HFD	100	65	25	
	CFD	200	200	100	
400	JXD6 (STD), JD6	65	35	25	200, 225, 250, 300, 350, 400
	HJXD6, HJD6	100	65	35	200, 225, 250, 300, 350, 400
	SJD6	65	35	25	200, 300, 400
	SHJD6 ¹	100	65	35	200, 300, 400
	CJD6, SCJD6	200	150	100	200, 300, 400
600	LXD (STD), LD6	65	35	25	250, 300, 350, 400, 450, 500, 600
	HLXD6, HID6	100	65	35	250, 300, 350, 400, 450, 500, 600
	SID6,	65	35	25	300, 400, 500, 600
	SHLD6 ¹	100	65	35	300, 400, 500, 600
	CLD6, SCLD6	200	150	100	300, 400, 500, 600

¹ Interchangeable trip main breakers and the SHJD and SHLD used as mains can be supplied only in top feed applications.

Table P3-8 – Subfeed Breaker Selection and Mounting Reference

Breaker Type	Mounting Orientation and Configuration		Maximum Interrupting Rating (ka)			Available Trip Values
	Vertical	Horizontal	240V AC	480V AC	600V DC	
FD, FXD HFD, HFX6	Twin	—	65	35	18	70, 80, 90, 100, 110, 125, 150, 200, 225, 250
	—	Single	100	65	25	
JXD, JD6 HJXD6 HJD6	—	Single	65	35	25	200, 225, 250, 300, 350, 400
			100	65	35	

Branch Device Limitations

For applied on systems requiring connections, some limitations may apply.

If the 2008 edition of the NEC has been adopted in the service area, the following statement will not apply.

By application rule (NEC 480.14) lighting and appliance panels are limited to 42 circuits installed. Each over current device pole counts as a circuit.

Table P3-9 – Neutral Connectors
(Based on 75°C copper)

Wire Range	Max. Number of Connections	Max. Amps
#14AWG - #4 AWG	46	85
#14AWG - #1/0 AWG	44	125
#4AWG - 350KCMIL	6	250
(1)#4AWG - 600KCMIL	1	400
(2)#6 - 350KCMIL		

Application

Type P3 Panelboards

Table P3-10 – Branch Circuit Breakers

Maximum Ampere Rating	Bolt-on Breaker Type	Number of Poles	Amp Rating	Maximum Interrupting Rating (kA)						
				Volts – AC						DC
				120	120/240	240	277	480	600	250
100	BL ¹	1	15 - 70	10	—	—	—	—	—	—
		2	15 - 100	—	10	—	—	—	—	—
		3	15 - 100	—	—	10	—	—	—	—
	BL HID	1	15 - 30	10	—	—	—	—	—	—
		2	15 - 30	—	10	—	—	—	—	—
	BLR	2	15 - 100	—	—	10	—	—	—	—
	BLE	1	15 - 30	10	—	—	—	—	—	—
		2	15 - 60	—	10	—	—	—	—	—
	BLEH	1	15 - 30	22	—	—	—	—	—	—
		2	15 - 60	—	22	—	—	—	—	—
	BLF	1	15 - 30	10	—	—	—	—	—	—
		2	15 - 60	—	10	—	—	—	—	—
	BLHF	1	15 - 30	22	—	—	—	—	—	—
		3	15 - 60	—	22	—	—	—	—	—
	BGL	2	15 - 30	10	—	—	—	—	—	—
		3	15 - 30	—	10	—	—	—	—	—
	BAF	1	15, 20	10	—	—	—	—	—	—
	BAFH	1	15, 20	22	—	—	—	—	—	—
	BLH ¹	1	15 - 70	—	22	—	—	—	—	—
		2	15 - 100	—	22	—	—	—	—	—
3		15 - 100	—	—	22	—	—	—	—	
HBL ¹	1	15 - 70	—	65	—	—	—	—	—	
	2	15 - 100	—	65	—	—	—	—	—	
	3	15 - 100	—	—	65	—	—	—	—	
BQD ¹	1	15 - 100	—	65	—	14	—	—	14	
	2	15 - 100	—	65	—	—	14	—	14	
	3	15 - 100	—	—	65	—	14	—	14	
125	NGB ^{1 2}	1	15 - 125	100	—	—	25	—	—	14
		2	15 - 125	—	100	100	—	25	—	—
		3	15 - 125	—	100	100	—	25	—	—
	HEB ^{3 4}	1	15 - 125	100	—	—	65	—	—	—
		2	15 - 125	—	100	100	—	65	—	—
		3	15 - 125	—	100	100	—	65	—	—
	ED4 ⁵	1	15 - 125	65	—	—	22	—	—	—
		2	15 - 125	—	—	65	—	18	—	30
		3	15 - 125	—	—	65	—	18	—	—
	ED6 ⁶	2	15 - 125	—	—	65	—	25	18	30
		3	15 - 125	—	—	65	—	25	18	—
	HED4 HHED6	1	—	100	—	—	—	—	—	—
2		15 - 125	—	—	—	65	—	—	—	
3		—	—	—	100	42	42	—	30	
225	QJ2 ⁶	2/3	60 - 225	—	—	10	—	—	—	
	QJH2 ⁶	2/3	60 - 225	—	—	22	—	—	—	
	QJ2-H ⁶	2/3	60 - 225	—	—	42	—	—	—	
	HQJ2H ⁶	2/3	100 - 225	—	—	100	—	—	—	

¹ BL, HBL, BLH and BQD breakers are mounted in common mountings in 3" or 6 pole increments.

² NGB breakers are counted in common mountings of 3" or 6 pole increments.

³ For use on 480Y/277 volt systems. Not suitable for 480 Delta 3 phase 3 wire systems.

⁴ NEB/HE breakers are counted in common mountings of 3" or 6 pole increments.

⁵ ED4, ED6, HED4 and HHED6 breakers are mounted in common mountings in 3" or (6) pole increments.

⁶ QJ Breakers are dual mounted and take 6" of unit space. Limit to (6) per panel max.

Typical Catalog Numbers

Type P3 Panelboards

Table P3-11 – Main Lugs Only – shown with aluminum bus, top fed, and surface trims

Maximum Panel Amp Rating	Unit Space (inches)	208Y/120V	240/120V	120/240V or 250 Vdc Max
		3 Phase, 4 Wire Catalog Number	3 Phase, 4 Wire Catalog Number	1 Phase, 3 Wire Catalog Number
250	27	P3C56ML250ATS	P3B56ML250ATS	P3A56ML250ATS
	33	P3C62ML250ATS	P3B62ML250ATS	P3A62ML250ATS
	39	P3C68ML250ATS	P3B62ML250ATS	P3A62ML250ATS
	45	P3C74ML250ATS	P3B74ML250ATS	P3A74ML250ATS
	51	P3C80ML250ATS	P3B80ML250ATS	P3A80ML250ATS
400	21	P3C56ML400ATS	P3B56ML400ATS	P3A56ML400ATS
	27	P3C62ML400ATS	P3B62ML400ATS	P3A62ML400ATS
	33	P3C68ML400ATS	P3B68ML400ATS	P3A68ML400ATS
	39	P3C74ML400ATS	P3B74ML400ATS	P3A74ML400ATS
	45	P3C80ML400ATS	P3B80ML400ATS	P3A80ML400ATS
600	21	P3C56ML600ATS	P3B56ML600ATS	P3A56ML600ATS
	27	P3C62ML600ATS	P3B62ML600ATS	P3A62ML600ATS
	33	P3C68ML600ATS	P3B68ML600ATS	P3A68ML600ATS
	39	P3C74ML600ATS	P3B74ML600ATS	P3A74ML600ATS
	45	P3C80ML600ATS	P3B80ML600ATS	P3A80ML600ATS
800	21	P3C56ML800ATS	P3B56ML800ATS	P3A56ML800ATS
	27	P3C62ML800ATS	P3B62ML800ATS	P3A62ML800ATS
	33	P3C68ML800ATS	P3B68ML800ATS	P3A68ML800ATS
	39	P3C74ML800ATS	P3B74ML800ATS	P3A74ML800ATS
	45	P3C80ML800ATS	P3B80ML800ATS	P3A80ML800ATS
Maximum Panel Amp Rating	Unit Space (inches)	240V	408Y/277V	480V ¹
		3 Phase, 3 Wire Catalog Number	3 Phase, 4 Wire Catalog Number	3 Phase, 3 Wire Catalog Number
250	27	P3D56ML250ATS	P3E56ML250ATS	P3F56ML250ATS
	33	P3D62ML250ATS	P3E62ML250ATS	P3F62ML250ATS
	39	P3D68ML250ATS	P3E68ML250ATS	P3F68ML250ATS
	45	P3D74ML250ATS	P3E74ML250ATS	P3F74ML250ATS
	51	P3D80ML250ATS	P3E80ML250ATS	P3F80ML250ATS
400	21	P3D56ML400ATS	P3E56ML400ATS	P3F56ML400ATS
	27	P3D62ML400ATS	P3E62ML400ATS	P3F62ML400ATS
	33	P3D68ML400ATS	P3E68ML400ATS	P3F68ML400ATS
	39	P3D74ML400ATS	P3E74ML400ATS	P3F74ML400ATS
	45	P3D80ML400ATS	P3E80ML400ATS	P3F80ML400ATS
600	21	P3D56ML600ATS	P3E56ML600ATS	P3F56ML600ATS
	27	P3D62ML600ATS	P3E62ML600ATS	P3F62ML600ATS
	33	P3D68ML600ATS	P3E68ML600ATS	P3F68ML600ATS
	39	P3D74ML600ATS	P3E74ML600ATS	P3F74ML600ATS
	45	P3D80ML600ATS	P3E80ML600ATS	P3F80ML600ATS
800	21	P3D56ML800ATS	P3E56ML800ATS	P3F56ML800ATS
	27	P3D62ML800ATS	P3E62ML800ATS	P3F62ML800ATS
	33	P3D68ML800ATS	P3E68ML800ATS	P3F68ML800ATS
	39	P3D74ML800ATS	P3E74ML800ATS	P3F74ML800ATS
	45	P3D80ML800ATS	P3E80ML800ATS	P3F80ML800ATS

¹ For 600V, change "F" in position 3 to "G." Price only branch breakers with 600V ratings.

Typical Catalog Numbers

Type P3 Panelboards

Table P3-12 – Main Circuit Breaker – shown with aluminum bus, top fed and surface trims.

Maximum Panel Amp Rating	Unit Space (inches)	208Y/120V	240/120V	120/240V or 250V dc Max
		3 Phase, 4 Wire Catalog Number	3 Phase, 4 Wire Catalog Number	1 Phase, 3 Wire Catalog Number
250	21	P3C56FD250ATS	P3B56FD250ATS	P3A56FD250ATS
	27	P3C62FD250ATS	P3B62FD250ATS	P3A62FD250ATS
	33	P3C68FD250ATS	P3B68FD250ATS	P3A68FD250ATS
	39	P3C74FD250ATS	P3B74FD250ATS	P3A74FD250ATS
	45	P3C80FD250ATS	P3B80FD250ATS	P3A80FD250ATS
400	9	P3C56JD400ATS	P3B56JD400ATS	P3A56JD400ATS
	15	P3C62JD400ATS	P3B62JD400ATS	P3A62JD400ATS
	21	P3C68JD400ATS	P3B68JD400ATS	P3A68JD400ATS
	27	P3C74JD400ATS	P3B74JD400ATS	P3A74JD400ATS
	33	P3C80JD400ATS	P3B80JD400ATS	P3A80JD400ATS
600	9	P3C56LD600ATS	P3B56LD600ATS	P3A56LD600ATS
	15	P3C62LD600ATS	P3B62LD600ATS	P3A62LD600ATS
	21	P3C68LD600ATS	P3B68LD600ATS	P3A68LD600ATS
	27	P3C74LD600ATS	P3B74LD600ATS	P3A74LD600ATS
	33	P3C80LD600ATS	P3B80LD600ATS	P3A80LD600ATS
Maximum Panel Amp Rating	Unit Space (inches)	240V	408Y/277V	480V ¹
		3 Phase, 3 Wire Catalog Number	3 Phase, 4 Wire Catalog Number	3 Phase, 3 Wire Catalog Number
250	21	P3D56FD250ATS	P3E56FD250ATS	P3F56FD250ATS
	27	P3D62FD250ATS	P3E62FD250ATS	P3F62FD250ATS
	33	P3D68FD250ATS	P3E68FD250ATS	P3F68FD250ATS
	39	P3D74FD250ATS	P3E74FD250ATS	P3F74FD250ATS
	45	P3D80FD250ATS	P3E80FD250ATS	P3F80FD250ATS
400	9	P3D56JD400ATS	P3E56JD400ATS	P3F56JD400ATS
	15	P3D62JD400ATS	P3E62JD400ATS	P3F62JD400ATS
	21	P3D68JD400ATS	P3E68JD400ATS	P3F68JD400ATS
	27	P3D74JD400ATS	P3E74JD400ATS	P3F74JD400ATS
	33	P3D80JD400ATS	P3E80JD400ATS	P3F80JD400ATS
600	9	P3D56LD600ATS	P3E56LD600ATS	P3F56LD600ATS
	15	P3D62LD600ATS	P3E62LD600ATS	P3F62LD600ATS
	21	P3D68LD600ATS	P3E68LD600ATS	P3F68LD600ATS
	27	P3D74LD600ATS	P3E74LD600ATS	P3F74LD600ATS
	33	P3D80LD600ATS	P3E80LD600ATS	P3F80LD600ATS

¹ For 600V, change "F" in position 3 to "G." Price only branch breakers with 600V ratings.

Standard Modifications

Type P3 Panelboards

P3 Panel Options

Enclosures

- Extra gutter to sides or ends of the can
- Hinged trims
- Door-in-door trims
- Screw to the box trims
- Trim mounted devices (Devices mounted and wired to the trim should also have hinged trim specified)
 - Pilot lights
 - Toggle switches
 - Push buttons
- Painted boxes
- Custom colors
- Increase gauge trims and boxes
- Stainless steel trims and boxes, Type 1
- Aluminum trims and boxes, Type 1
- NEMA 3R enclosures

Panel Modifications

- Main Bus
Standard main bus in tin-plated aluminum. For copper main bus, add from the table for each panel. Includes copper neutral cross bar. For copper neutral branch lugs, see miscellaneous.
- Split bus requires 6" of unit space.
- Compression lug for MLO
- Compression lugs on Main breaker (may require extra width or length on enclosure).
- Contactor mains or submain
 - Asco 920 through 225 amps - Adds 12" unit space as main, 15" unit space as submain
 - Asco 911 through 150 amps - Adds 21" unit space.
 - Siemens LEN through 30 amps - Adds 12" unit space. Makes box 10" deep.
- Control power transformers (contact engineering for extra gutter requirements)
- Branch and main breaker accessories
 - Handle blocks
 - Handle locks
 - Aux. Contacts¹
 - UVR¹
- Feed-thru lugs
Cannot be used in conjunction with TVSS or sub-feed breakers. See Page 3-10 for unit space impact. Wire ranges are the same as main lug.
- 200% neutral
- Copper lugs, mechanical
- Bus mounted TVSS
- Service Entrance Label

Type P3 Panelboards are factory labeled suitable for use as service entrance equipment when NEC requirements are met. A panelboard cannot have more than six main disconnects, unless it is a lighting and appliance branch panelboard. Lighting and appliance branch panelboards are limited to two main disconnects.

- NEMA 3R/12 enclosures
- NEMA 4 enclosures
- NEMA 4X enclosures
- Special keyed locks
 - TEY
 - TEU1
 - Cat 60
 - LL803
 - LL806
 - Yale
- Meters (Contact application engineering for space requirements)
- Panel Skirts
- Gasketing between trim and box (Type 1)
- Name Plates

- Grounding of Panelboards
Ground Bars except for brazed-to-box are shipped with the panel interior.
 - Non-Insulated Equipment Ground Bar – Standard
 - Copper Non-Insulated Ground Bar
 - Al Insulated Equipment Ground Bar
 - Cu Insulated Equipment Ground Bar
 - Ground Bar Brazed to Box (recommended for painted boxes)
- Shunt Trip¹
BL, BLH, HBL, BQD, NGB, NEB, HEB, ED2, ED4, HED4, ED6, HED6, HHED6, QJ2, QJ2H, QJH2, HQJ2H as branch only. BL, BLH, HBL, ED2, ED4, HED4, ED6, HED6, HHED6 uses 1" unit space for shunt trip. All others may be used on mains or subfeeds.

FXD6, HFD6, JXD6, JD6, HJD6, HJXD6

- Remote control switches – 480V AC max. mounted in a 23" enclosure to be cable connected to the panel.
- Time Clocks – mounted in a 23" enclosure to be cable connected to the panel. Sangamo, Tork or Paragon time clock can be supplied and mounted in panelboard cabinet.

Description

Time Clock (1-or 2-Pole, Single or Double Throw Contacts; 3-Pole Single Throw)

277V Maximum with Plain Dial

Options:

Astronomical Dial

An Omitting Device

Reserve Power or Carryover

Space and Mounting Provisions Only

¹ Accessories on 1" pole breakers (BL, BQD, ED) will take unit space.

Standard Modifications

Type P3 Panelboards

Table P3-13 – Option Combinations

Amps	Incoming	Subfeed Lugs ¹	Feed-thru Lugs	TVSS	(1) FD Subfeed Breaker	(2) FD Subfeed Breaker	(1) JD Subfeed Breaker	200% Neutral	Min. Box Size (in.)	Unit Space (in.)	
250A	Main Lug Only	—	•	—	—	—	—	•	56	27	
		—	—	•	—	—	—	•	56	15	
		—	—	—	•	•	—	—	56	15	
		—	—	—	—	•	•	—	56	9	
	Main Lugs w/Subfeed Lugs	•	—	—	—	—	—	—	•	56	21
		•	•	—	—	—	—	—	•	56	21
		•	—	•	—	—	—	—	•	56	9
		•	—	—	—	•	—	—	•	56	9
		•	—	—	—	—	•	—	•	62	9
	FD Main Breaker Horizontally Mtd.	—	•	—	—	—	—	—	•	56	21
—		—	•	—	—	—	—	•	56	9	
—		—	—	—	•	—	—	•	56	9	
FD Main Breaker Vertically Mtd.	—	•	—	—	—	—	—	•	56	15	
	—	—	•	—	—	—	—	•	62	9	
CFD Main Breaker Vertically Mtd.	—	•	—	—	—	—	—	•	56	9	
	—	—	•	—	—	—	—	•	68	9	
400 ²	Main Lug Only	• ⁴	—	—	—	—	—	•	56	21	
		—	•	—	—	—	—	• ⁴	56	15	
		—	—	•	—	—	—	—	•	56	9
		—	—	—	•	—	—	—	•	56	9
		—	—	—	—	•	—	—	•	62	9
		—	—	—	—	—	•	—	•	56	9
	JD Main Breaker	—	—	—	—	—	—	—	•	56	9
		—	•	—	—	—	—	—	• ⁴	62	9
		—	—	•	—	—	—	—	•	68	9
		—	—	—	—	•	—	—	•	68	9
		—	—	—	—	—	•	—	•	74	9
	CJD Main Breaker	—	—	—	—	—	—	—	• ⁴	68	9
		—	•	—	—	—	—	—	•	62	9
		—	—	•	—	—	—	—	•	68	9
		—	—	—	•	—	—	—	•	74	9
—		—	—	—	•	—	—	•	74	9	
600 ^{2,3}	Main Lug Only	—	—	—	—	—	—	•	56	21	
		—	•	—	—	—	—	—	•	56	15
		—	—	•	—	—	—	—	•	56	9
		—	—	—	•	—	—	—	•	56	9
		—	—	—	—	•	—	—	•	62	9
		—	—	—	—	—	•	—	•	56	9
	LD Main Breaker	—	—	—	—	—	—	—	•	56	9
		—	•	—	—	—	—	—	•	62	9
		—	—	•	—	—	—	—	•	68	9
		—	—	—	—	•	—	—	•	68	9
		—	—	—	—	—	•	—	•	74	9
	CLD Main Breaker	—	—	—	—	—	—	—	•	62	9
		—	•	—	—	—	—	—	•	68	9
		—	—	•	—	—	—	—	•	74	9
		—	—	—	—	•	—	—	•	74	9
—		—	—	—	—	•	—	•	80	9	
800	Main Lug Only (2) 600Kcmil	—	—	—	—	—	—	•	56	21	
		—	•	—	—	—	—	—	•	56	9
		—	—	•	—	—	—	—	•	56	9
		—	—	—	•	—	—	—	•	56	9
		—	—	—	—	•	—	—	•	62	9
	Main Lug Only (2) 500 Kcmil	—	—	—	—	—	—	—	•	56	9
		—	—	•	—	—	—	—	—	56	15
		—	—	—	•	—	—	—	—	62	9
		—	—	—	—	•	—	—	—	62	9
		—	—	—	—	—	•	—	—	62	9

¹ Subfeed lugs are currently not offered as a standard with main circuit breakers.

² Subfeed lugs on panels above 400A are not standard.

³ A 200% neutral cannot be provided along with a 400A subfeed breaker or because the breaker blocks the 4th lug position.

⁴ This feature is not available when the panel is fed by (2) cables per phase and neutral.

Connector Modifications

Type P3 Panelboards

Compression Lugs

Table P3-14 – Lugs

Style	Amp Rating	Breaker Type	Compression Connectors	Box Height Addition
MLO	250	N/A	(1)#6 AWG - 350 Kcmil	—
	400	N/A	(1) 250 - 500 Kcmil or (2)# 1/0 AWG - 250 Kcmil	—
	600	N/A	(2)#3/0 AWG - 500 Kcmil	—
	800	N/A	(2) 400-750 Kcmil Al only	—
Main Breaker	250	FXD6, HFD6, CFD6	(1)#6 AWG - 350 Kcmil Cu or Al	CFD6 requires an additional 6.0" box height
	400	JD6, JXD6, HJD6, CJD6, SJD6, SHJD6, SCJD6	(2)#1/0 AWG - 500 Kcmil Cu or Al	6
	600	LD6, LXD6, HLD6, CJD6, SLD6, SHLD6, SCLD6	(2)#2/0 AWG - 500 Kcmil Cu or Al	6

Table P3-15 – Alternate Lugs

Style	Amp Rating	Breaker Type	Compression Connectors	Box Height Addition
MLO	400	N/A	(1) 250 - 750 Kcmil or (2)#6 AWG - 350 Kcmil Cu or Al	6
	800	N/A	(2) 600 Kcmil	
Main Breaker	400	JD6, JXD6, HJD6, CJD6, SJD6, SHJD6, SCJD6	(1)#4/0 AWG - 750 Kcmil Cu or Al	6

Enclosure Modifications

NEMA-4 For Type P3
Water Tight, Dust Tight, Steel Enclosure
(consult plant for actual enclosure size)

Table P3-16

Box Height Inches	Enclosure Size		
	H	W	D
56	60	36	8
62	66	36	8
68	72	36	8
74	78	36	8
80	84	36	8

NEMA-4X For Type P3
Water Tight, Dust Tight and Corrosion Resistant
(consult plant for actual enclosure size)

Table P3-17

Box Height Inches	Enclosure - Stainless Steel and Steel with Epoxy Coating			Enclosure - Fiberglass Size (inches)		
	H	W	D	H	W	D
56	60	36	12	60	36	12
62	66	36	8	66	36	8
68	72	36	8	72	36	8
74	78	36	8	78	36	8
80	84	36	8	84	36	8

Remote Switch Modifications

Table P3-18 – Control Power Transformer

Size	VA
0,1	50
2	75
3	150
4	250

Table P3-19 – Application For Remote Switch

Switch Type	Modification
920	Adds 12" to unit space
911	≤ 225A Adds 21" unit space
LEN	>30A ≤ 100 Adds 12" to unit space 100 A ≤ 200 Adds 12" to unit space and 10" Dp. min.

Table P3-20 – Remote Control Switch Modification

Description
Auxiliary Contacts (mounted, not wired)
Ea. 2-Wire Control

Dimensions

Type P3 Panelboards

Type 1 Box

Box is symmetrical

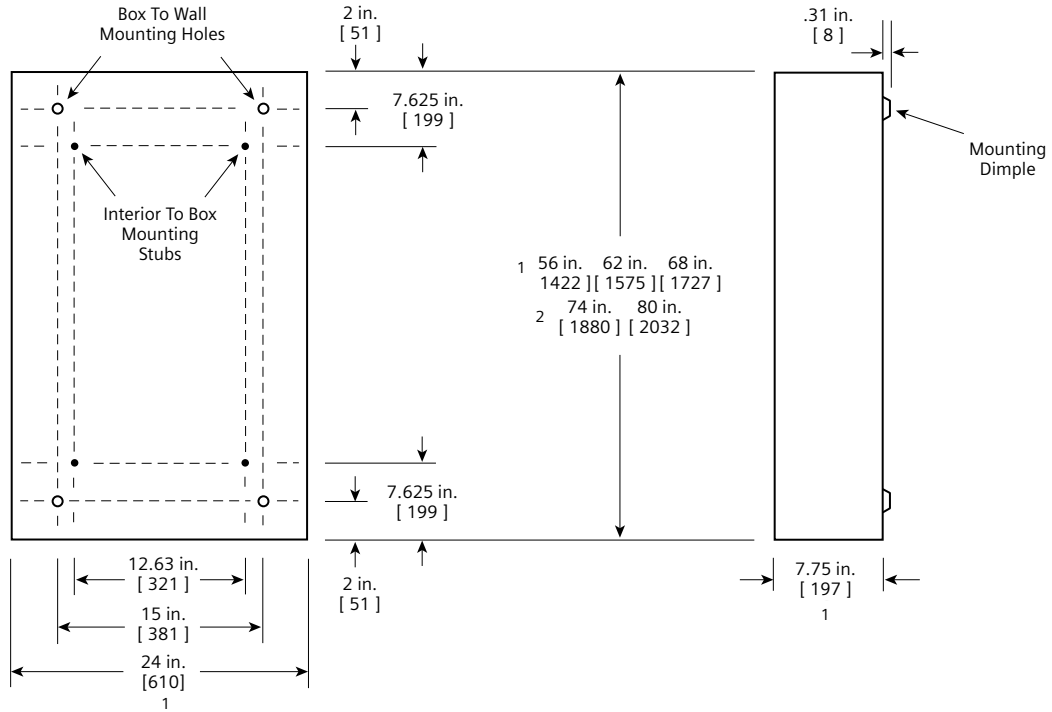

Type 3R and 3R/12 Box

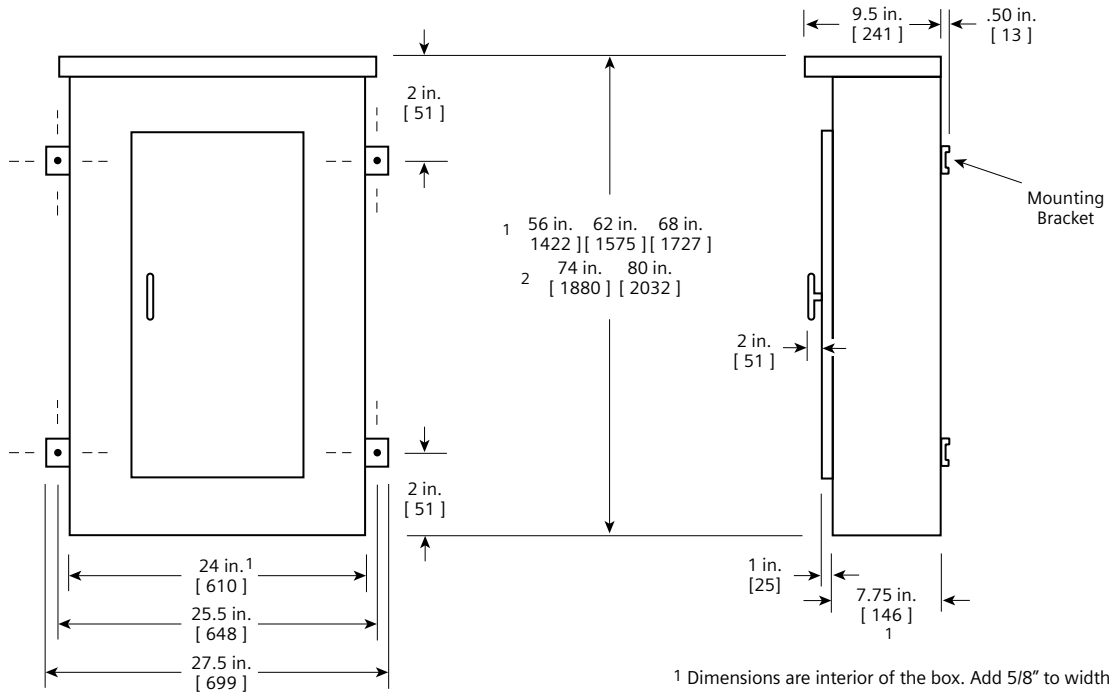

1 Dimensions are interior of the box. Add 5/8" to width for absolute dimension. Add 1/8" to height for absolute dimension.
 2 See table P3-2 to match ratings.

Dimensions shown in inches and millimeters [].

Kits and Accessories

Type P3 Panelboards

Table P3-21 – Standard Enclosures

Box Height (in.)	Catalog Number				
	Type 1 Standard Trim			Type 3R	Type 3R/12
	Box	Surface	Flush		
56	24WD56	P3S56	P3F56	24NRD56	24WPD56
62	24WD62	P3S62	P3F62	24NRD62	24WPD62
68	24WD68	P3S68	P3F68	24NRD68	24WPD68
74	24WD74	P3S74	P3F74	24NRD74	24WPD74
80	24WD80	P3S80	P3F80	24NRD80	24WPD80

Options For Type 1 Trims

Items must be ordered as manual line item on factory

Hinged trim – Add “H” suffix

Door-in-door – Add “D” suffix

Metal card holder – Add “M” suffix

Table P3-22 – Breaker Kits and Accessories

Kit No.	Description	Contents
BBKB32	BL/BQD 6-pole 3” branch breaker kit	Kit contains top barrier, (3) A/C connectors, (1) B connector, hardware
BBKND32	NGB 6-pole 3” branch mounting kit	Kit contains top barrier, (3) A/C connectors, (1) B connector, hardware
BBKED32	NEB/HEB 6-pole 3” branch mounting kit	Kit contains top barrier, (3) A/C connectors, (1) B connector, hardware
BBKED32	ED 6-pole 3” branch breaker kit	Kit contains breaker support, inter-phase barriers, (3) A/C connectors, (1) B connector, hardware
BBKQ1	QJ branch breaker kit for 2 and 3-pole single mount	Kit contains all connectors and cover plates necessary to mount 2 and 3 pole breakers
BBKQ2	Branch breaker kit for 2 and 3 pole QJ twin mount	Kit contains all connectors and cover plates necessary to mount both 2 and 3-pole breakers
DFFP3	Deadfront filler 3”	3” empty space filler and hardware
DFFP6	Deadfront filler 6”	6” empty space filler and hardware
P3BK1	P3 bonding kit	Bonding strap and hardware
QF3	Filler plate for BL, BQD, ED frame branch breaker provisions	1” filler plate
EBF1	Filler plate for NEB/HEB branch breaker provision content	1” filler plate



P4 Panelboards

Description	Page	
General Information	4-2	Branch Breaker Side Gutter 4-7
Selection and Application	4-2	Typical Catalog Numbers 4-8
Applications	4-3 – 4-6	Main Lugs Only 4-8
Main Breaker Selection	4-3	Main Circuit Breakers Only 4-8
Main Switch Connectors	4-3	Modifications and Additions 4-9
Enclosure Selection	4-3	Connector Modifications 4-10
Main Breaker Unit Space Dimensions	4-3	Compression Lugs 4-10
Main Lugs Only Unit Space Dimensions	4-4	Alternate Lugs 4-10
Branch Switch Unit Space	4-4	Dimensions 4-11
Branch Circuit Breakers	4-5 – 4-6	Kits and Accessories 4-12 – 4-13
Branch Breaker Unit Space	4-6	

Type P4 Panelboards

The Siemens P4 is a medium-sized distribution panel designed for applications that require more or larger branch devices and higher amp ratings than typical lighting panels can support. Even with the increased capacity, this panel is a space saver with its 32" width and 10" depth. The P4 panel offers a wide array of factory-assembled options and has the ability to mix breaker frames in unit space up to 800 amps and fusible switches up to 200 amps. Bussing options vary from standard temperature rated aluminum to temperature rated copper and 750NSi aluminum and 1000A/Si copper designs. All aluminum bussing in the P4 panel is tin-plated. All Copper bussing in the P4 panel is silver plated. Integrated time clocks, bus mounted contactors as mains or submains, split bus and subfeed lugs (up to 600 amp) are just a few of the options of this flexible panel.

The 4 panel configurations defined by the unit space allowed for a given amperage, main device and box height. The P4 panel starts with a 60" high box. All of the branch devices are unit space mounted. Breakers and switches can be mixed and matched to meet customer requirements.

Main Lug / Main Breaker / Main Switch

Enclosure – Standard Type 1 enclosure is 32" wide x 10" deep. X Box Height is determined by main device and unit space. See charts for box height.

Voltage – 600 Vac Max.
250 Vdc Max.

Amperage – 400-800 amp main breaker, 400-1200 amp MLO, 100-200 amp main switch.

Selection and Application

1) To specify a particular panelboard, first determine voltage, system, amperage and type of main, amperage and type of branch devices, and modifications, if any. (Step 1)

2) List branch devices and modifications requiring space additions. List unit space requirements of each.

Note: Some units are twin mounted meaning two breakers occupy the same unit space.

Step #1	
Amperage	400
Voltage	208Y/120
System	3 Phase, 4 wire
Main	Main Breaker
Branches	5-125/3, 2-225/3, 1-250/3
Modifications	None
Feed	Top
Mounting	Surface

Step #2	
5-125/3 ED4	3.75" = 11.25" Twin Mounted
2-225/3 QJ2	5" = 5" Twin Mounted
1-250/3 FXD6	5" = 5" 21.25
Enclosure is B275 from Selection Chart on Page 4-3. (32" wide, 75" high, 10" deep)	

Step #3
1-P4C75JX400ATS
3-ED4 1-Pole Provision
5-125/3
2-225/3 QJ2
1-250/3 FXD6
12" Space

Short Circuit Rating – 200 KAIC Max. symmetrical or equal to the lowest rated device installed unless a series rating is indicated. Panels with subfeed or feed-thru lugs without a main device, circuit breaker or fusible unit, are limited to a three-cycle rating. The three-cycle rating for the P4 panel is limited to 42 KAIC. Note that the main device may be mounted remote from the panel.

Bussing – The P4 panel has more options to meet market requirements. The standard bussing is temperature rated aluminum. The rating is per the requirements of UL 67 – the standard for panelboards. All aluminum bussing is tin-plated. Optional bussing for the P4 panel is: 750 A/Si aluminum, temperature rated copper, and 1000 A/Si copper. The copper bus option for this panel is silver-plated.

Weight – Approximate

Total panelboard weight when filled with a normal quantity of breakers and accessories is about 8 lbs. (1 kg) per inch (54g per mm) of box height.

Table P4-1 – Main Lugs¹

Ampere Rating	Connectors Suitable for Copper or Aluminum
400	(1) - #3/0 AWG-600 Kcmil (2) - #3/0 AWG-250 Kcmil
600	(2) - #3/0 AWG-600 Kcmil
800	(3) - #3/0 AWG-600 Kcmil
1000	(4) - #3/0 AWG-600 Kcmil
1200	(4) - #3/0 AWG-600 Kcmil

¹ Alternate lugs for 750 kcmil cable are available, but result in significant loss of branch unit mounting space. Consult Siemens.

Table P4-2 – Gauge Steel of Boxes Fronts, Surface and Flush

Dimensions in inches (mm)		Gauge Steel	
Width	Height	Box	Fronts
32"	60 - 75 - 90	#16 ¹	#14 (1 piece trim)
(813)	(1524, 1905, 2286)		#16 (4 piece trim)

¹ Box has 16 gauge side panels and 12 gauge back support.

Select appropriate enclosure height from selection chart on page 4-3, based on unit space requirements. (Step 2)

3) Select panelboard catalog number from appropriate table based upon voltage, system, amperage and unit space requirements. (Step 3)

Application

Type P4 Panelboards

Table P4-3 – Main Breaker Selection

Ampere rating	Breaker type			Maximum IC (KA) Symmetrical Amperes				Continuous Current Rating
	Trip type ¹	Frame type	Breaker family	240V	480V	600V	Main Breaker Unit Space in inches (mm)	
400A	TMTU	JXD6, JD6	Sentron	65	35	22	8.75 (222)	200, 225, 250, 300, 350, 400
		HJXD6, HJD6	Sentron	100	65	35	8.75 (222)	200, 225, 250, 300, 350, 400
		HHJXD6, HHJD6	Sentron	200	100	50	8.75 (222)	200, 225, 250, 300, 350, 400
		CJD6	Sentron	200	150	100	8.75 (222)	200, 225, 250, 300, 350, 400
	ETU	NJ	VL	65	35	25	6.25 (159)	250, 400
		SJD6	Sentron	65	35	25	8.75 (222)	200, 300, 400
		HJ	VL	100	65	25	6.25 (159)	250, 400
		SHJD6	Sentron	100	65	35	8.75 (222)	200, 300, 400
		LJ	VL	200	100	25	6.25 (159)	250, 400
		SCJD6	Sentron	200	150	100	8.75 (222)	200, 300, 400
600A	TMTU	LXD6	Sentron	65	35	25	8.75 (222)	450, 500, 600
		LD6	Sentron	65	35	25	8.75 (222)	250, 300, 350, 400, 450, 500, 600
		HLXD6, HLD6	Sentron	100	65	35	8.75 (222)	250, 300, 350, 400, 450, 500, 600
		HHLXD6, HHL6	Sentron	200	100	50	8.75 (222)	250, 300, 350, 400, 450, 500, 600
		CLD6	Sentron	200	150	100	8.75 (222)	250, 300, 350, 400, 450, 500, 600
	ETU	NL ²	VL	65	35	18	6.25 (159)	400, 600
		SLD6	Sentron	65	35	25	8.75 (222)	300, 400, 500, 600
		HL ²	VL	100	65	18	6.25 (159)	400, 600
		SHLD6	Sentron	100	65	35	8.75 (222)	300, 400, 500, 600
		LL ²	VL	200	100	18	6.25 (159)	400, 600
SCLD6	Sentron	200	150	100	8.75 (222)	300, 400, 500, 600		
800A	TMTU	NM ³	VL	65	35	25	8.75 (222)	600, 700, 800
		HM ³	VL	100	65	35	8.75 (222)	600, 700, 800
		LM ³	VL	200	100	50	8.75 (222)	600, 700, 800
	ETU	NM ³	VL	65	35	25	8.75 (222)	600, 800
		HM ³	VL	100	65	35	8.75 (222)	600, 800
		LM ³	VL	200	100	50	8.75 (222)	600, 800

¹ TMTU = Thermal Magnetic Trip Unit and ETU = Electronic Trip Unit.

² 100% ratings are not available for the VL LG frame, replace with VL MG frame @ 600A rated 100%.

³ 100% ratings are not available for the VL MG. Use a P5 panel for this application with the VL NG frame @ 800A rated 100%.

Table P4-4 – Enclosure Selection ¹

Enclosure Dimension in Inches (mm)			Available Unit Space in Inches (mm) Dimension "C" in Fig. 4-1		
H	W	D	Main Lug Only	Main Breaker	800A
			400 / 800A	400A/600A	
60 (1524)	32 (813)	10 (254)	30 (762)	23.75 (603)	21.25 (540)
75 (1905)	32 (813)	10 (254)	45 (1143)	38.75 (984)	26.25 (921)
90 (2286)	32 (813)	10 (254)	60 (1524)	53.75 (1365)	51.25 (1302)

¹ Standard trim is four piece without door. Surface or flush one piece trim is available for 32 in. (813 mm) wide circuit breaker panels.

Table P4-5 – Main Breaker Lug Location Reference (Fig. P4-1)

Ampere Rating	Breaker Type	Dimensions in Inches (mm)	
		A	B
400	JXD6, JD6, HJXD6, HJD6	10.425 (265)	13.125 (333)
400	HHJXD6, HHJD6		
400	NJ, HJ, LJ		
400	SJD6, SHJD6		
400	CJD6, SCJD6		
600	LXD6, LD6, HLXD6, HLD6, HHLXD6, HHL6		
600	NL, HL, LL		
600	SLD6, SHLD6		
600	CLD6, SCLD6		
800	NM, HM, LM,		

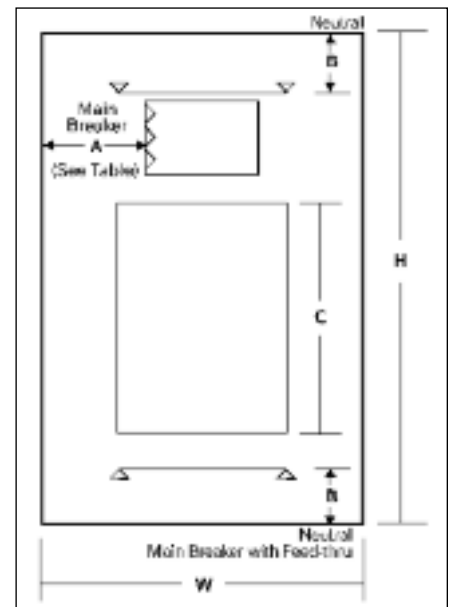
Fig. P4-1

Application

Type P4 Panelboards

Table P4-6 – Main Lugs Location Reference (Fig. P4-2)

Lugs	Dimensions in inches (mm)						
	Main Lug					Neutral	
	400A A	600A B	800A C	1000A D	1200A E	400-600A F	800-1200A G
Standard	16.500 (419)	16.750 (425)	15.969 (406)	15.969 (406)	15.969 (406)	13.125 (333)	13.125 (333)
Oversize	16.500 (419)	21.750 (552)	25.969 (660)	25.969 (660)	25.969 (660)	18.125 (460)	23.125 (587)
Crimp	19.187 (487)	18.250 (464)	18.687 (475)	18.250 (464)	18.250 (464)	15.937 (405)	15.937 (405)
Standard w/Subfeed	16.750 (425)	15.969 (406)	—	—	—	13.125 (333)	13.125 (333)
Standard w/Feed-thru	16.500 (419)	16.750 (425)	—	—	—	13.125 (333)	13.125 (333)

Fig. P4-2

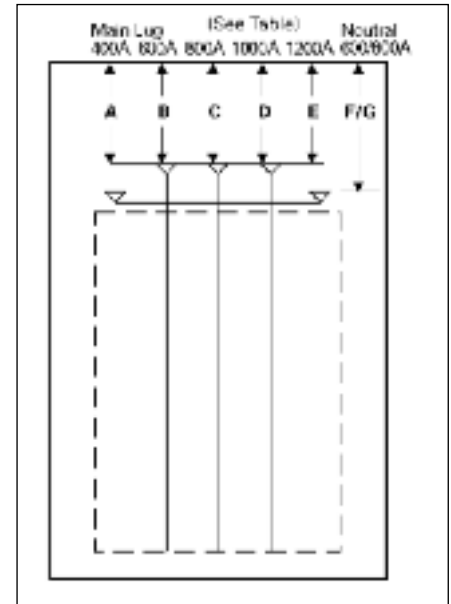

Table P4-7 – Available Unit Space – MLO

Lug Type	Box Height	Dimensions in inches (mm)				
		Ampere Rating				
		400	600	800	1000	1200
Standard Mechanical	60	30	30	30	30	30
	75	45	45	45	45	45
	90	60	60	60	60	60
Oversized Mechanical	60	30	25	20	20	20
	75	45	40	35	35	35
	90	60	55	50	50	50
Crimp Type	60	25	25	25	25	24
	75	40	40	40	40	40
	90	55	55	55	55	55
Std Mechanical W/ Sub-feed	60	30	30	—	—	—
	75	45	45	—	—	—
	90	60	60	—	—	—
Std. Mechanical W/ Feed-thru	60	20	20	12.5	12.5	12.5
	75	35	35	27.5	27.5	27.5
	90	50	50	42.5	42.5	42.5

Table P4-8 – Branch Switch Unit Space

Ampere Rating	Number of Poles	Unit Space in inches (mm)		AC Voltage	Cables Per Connector	Connectors Suitable For Copper or Aluminum
		Twin Mounted	Single Mounted			
30-30	2,3	2.50 (64)	—	240	1	#14 - #8 AWG (Cu Only)
30-30	2,3	5.00 (127)	—	240	1	#14 - #4 AWG
30-60	2,3	5.00 (127)	—	240	1	#14 - #4 AWG
60-60	2,3	5.00 (127)	—	240	1	#14 - #4 AWG
60-100	2,3	7.50 (191)	—	240	1	#10 - #1/0 AWG
100-100	2,3	7.50 (191)	—	240	1	#10 - #1/0 AWG
200-200	3	10.00 (254)	—	240	1	#6 AWG - 350 Kcmil
200	2	—	7.50 (191)	240	1	#6 AWG - 350 Kcmil
200	3	—	10.00 (254)	240	2	#6 AWG - 350 Kcmil
30-30	2,3	7.5 (191)	—	600	1	#14 - #8 AWG
30-60	2,3	7.5 (191)	—	600	1	#14 - #4 AWG
60-60	2,3	7.5 (191)	—	600	1	#14 - #4 AWG
60-100	2,3	7.5 (191)	—	600	1	#10-#1/0 AWG
100-100	2,3	7.5 (191)	—	600	1	#10-#1/0 AWG
200-200	3	10.00 (254)	—	600	1	#6 AWG - 250 Kcmil
100	2,3	—	7.50 (191)	600	1	#10-#1/0 AWG
200	2,3	—	10.00 (254)	600	1	#6 AWG - 250 Kcmil

Application

Type P4 Panelboards

Table P4-9 – Branch Circuit Breakers

Maximum Ampere Rating	Bolt-on Breaker Type	Number of Poles	Trip Amp Rating	Maximum IC (KA) Symmetrical Amperes								
				Voltage -AC								
				120	120/240	240	277	480/ 277	480	600/347	600	
100	BLF	1	15-30	10	—	—	—	—	—	—	—	—
		2	15-60	—	10	—	—	—	—	—	—	—
	BLHF	1	15-30	22	—	—	—	—	—	—	—	—
		2	15-60	—	22	—	—	—	—	—	—	—
	BLE	1	15-30	10	—	—	—	—	—	—	—	—
		2	15-60	—	10	—	—	—	—	—	—	—
	BLEH	1	15-30	22	—	—	—	—	—	—	—	—
		2	15-60	—	22	—	—	—	—	—	—	—
	BAF, BAFc	1	15-20	10	—	—	—	—	—	—	—	—
		1	15-20	22	—	—	—	—	—	—	—	—
	BAFH, BAFHC	1	15-20	22	—	—	—	—	—	—	—	—
		2	15-20	—	10	—	—	—	—	—	—	—
	BAFH	2	15-20	—	22	—	—	—	—	—	—	—
		2	15-20	—	22	—	—	—	—	—	—	—
	BGL	2	15-30	10	—	—	—	—	—	—	—	—
		3	15-30	—	10	—	—	—	—	—	—	—
		3	15-30	—	10	—	—	—	—	—	—	—
	BLR	2	15-100	—	—	10	—	—	—	—	—	—
		1	15-70	10	—	—	—	—	—	—	—	—
		2	15-100	—	10	—	—	—	—	—	—	—
	BL	3	15-100	—	—	10	—	—	—	—	—	—
		3	15-100	—	—	10	—	—	—	—	—	—
		3	15-100	—	—	10	—	—	—	—	—	—
	BLH	1	15-70	—	22	—	—	—	—	—	—	—
		2	15-100	—	22	—	—	—	—	—	—	—
		3	15-100	—	—	22	—	—	—	—	—	—
	HBL	1	15-70	—	65	—	—	—	—	—	—	—
		2	15-100	—	65	—	—	—	—	—	—	—
3		15-100	—	—	65	—	—	—	—	—	—	
BQD	1	15-100	—	65	—	14	—	—	—	—	—	
	2	15-100	—	65	—	—	14	—	—	—	—	
	3	15-100	—	—	65	—	14	—	—	—	—	
BQD6 ¹	1	15-70	65	—	—	—	—	—	—	—	—	
	2/3	15-100	—	—	65	—	—	—	—	—	10	
BL (HID)	1/2	15-30	—	10	—	—	—	—	—	—	—	
	1	15-60	—	10	—	—	—	—	—	—	—	
BLF (GFCI)	2	40-60	—	10	—	—	—	—	—	—	—	
	2	40-60	—	10	—	—	—	—	—	—	—	
BLE (EQ GFI)	1/2	15-30	—	10	—	—	—	—	—	—	—	
	1/2	15-30	—	10	—	—	—	—	—	—	—	
BLG (SWN)	2	15-30	10	—	—	—	—	—	—	—	—	
	3	15-30	—	10	—	—	—	—	—	—	—	
BLHF (GCFI)	1/2	15-30	—	22	—	—	—	—	—	—	—	
	1/2	15-30	—	22	—	—	—	—	—	—	—	
125	NGB	1	15-125	100	—	—	25	—	—	—	—	
		2/3	15-125	—	100	100	—	25	—	14	—	
	NEB	1	15-125	100	85	85	35	—	—	—	—	
		2/3	15-125	—	85	85	—	35	35	22	—	
	HEB	1	15-125	200	100	100	65	—	—	—	—	
		2/3	15-125	100	100	—	100	65	25	25	—	
	ED4	1	15-125	65	—	—	22	—	—	—	—	
		2/3	15-125	—	65	65	—	18	18	—	—	
	ED6	2	15-125	—	—	—	—	25	25	30	—	
		3	15-125	—	—	65	—	25	25	—	18	
	HED4	1	15-125	100	—	—	65 ²	—	—	—	—	
		2/3	15-125	—	100	100	—	42	42	—	—	
HHED6	2/3	15-125	100	—	—	—	65	65	18	18		
	2/3	15-125	200	—	—	—	200	200	100	100		
225	QJ2	2/3	60-225	—	—	10	—	—	—	—	—	
		2/3	60-225	—	—	22	—	—	—	—	—	
	QJ2H	2/3	60-225	—	—	42	—	—	—	—	—	
		2/3	60-225	—	—	100	—	—	—	—	—	
250	FXD6, FD6	2/3	70-250	—	—	65	—	35	35	18	18	
		2/3	70-250	—	—	100	—	65	65	25	25	
	HFXD6, HFD6	2/3	70-250	—	—	200	—	100	100	25	25	
		2/3	70-250	—	—	200	—	200	200	100	100	
400	JXD6, JD6, SJD6	2/3	200-400	—	—	65	—	35	35	25	25	
		2/3	200-400	—	—	100	—	65	65	35	35	
	HJXD6, HJD6, SHJD6	2/3	200-400	—	—	200	—	100	100	50	50	
		2/3	200-400	—	—	200	—	150	150	100	100	
600	LXD6	2/3	450-600	—	—	65	—	35	35	25	25	
		2/3	250-600	—	—	65	—	35	35	25	25	
	SLD6	2/3	300-600	—	—	65	—	35	35	25	25	
		2/3	250-600	—	—	100	—	65	65	35	35	
	SHLD6	2/3	300-600	—	—	100	—	65	65	35	35	
		2/3	250-600	—	—	200	—	100	100	50	50	
	HHLXD6, HHLXD6	2/3	250-600	—	—	200	—	100	100	50	50	
		2/3	450-600	—	—	200	—	150	150	100	100	
SCLD6	2/3	300-600	—	—	200	—	150	150	100	100		
	2/3	300-600	—	—	200	—	150	150	100	100		

1 CSA listed only at 600V AC.

2 15-30A trip (shown) 65 KA, 35-100A 25 KA.

Application

Type P4 Panelboards

Table P4-10 – Branch Circuit Breakers (VL)

Maximum Ampere Rating	Bolt-on Breaker Type	Number of Poles	Trip Amp Rating	Maximum IC (KA) Symmetrical Amperes							
				Volts – AC							
				120	120/240	240	277	480/277	480	600/347	600
150 ¹	ND	3	60 - 150	—	65	65	—	35	35	18	18
	HD	3	60 - 150	—	100	100	—	65	65	20	20
	LD	3	60 - 150	—	200	200	—	100	100	25	25
250 ¹	NF	3	100 - 250	—	65	65	—	35	35	18	18
	HF	3	100 - 250	—	100	100	—	65	65	20	20
	LF	3	100 - 250	—	200	200	—	100	100	25	25
400 ¹	NJ	3	250 - 400	—	65	65	—	35	35	25	25
	HJ	3	250 - 400	—	100	100	—	65	65	25	25
	LJ	3	250 - 400	—	200	200	—	100	100	25	25
600 ¹	NL	3	400 - 600	—	65	65	—	35	35	18	18
	HL	3	400 - 600	—	100	100	—	65	65	18	18
	LL	3	400 - 600	—	200	200	—	100	100	18	18
800	NM	2/3	600 - 800	—	65	65	—	35	35	25	25
	HM	2/3	600 - 800	—	100	100	—	65	65	35	35
	LM	2/3	600 - 800	—	200	200	—	100	100	50	50

¹ Only offered with Electronic Trip Units.

Table P4-11 – Branch Breaker Unit Space Requirements

Amp Rating	Breaker Type	Mounting Height in Inches (mm)	
		Twin	Single
100 ¹	BL, BLH, HBL, BQD, BLE, BLEH, BLR, BLF, BLHF, BAF, BAFC, BAFH, BAFCH	3.75 (95)	—
	BGL, BL, BLH, HBL, BQD – with accessories	6.25 (159)	—
125	NGB, NEB, HEB, ED4, ED6, HED4, HHED6, CED6, NGB, ED4 ^{1 2} , ED6 ^{1 2} , HED4 ^{1 2} , HHED6 ^{1 2} , CED6 ^{1 2} – with accessories	3.75 (95)	—
150	ND, HD, LD	5.00 (127)	—
225	QJ2, QJH2, QJ2-H, HQJ2H	5.00 (127)	—
250	FD6, FXD6, HFD6, HFXD6, HHFD6, HHFXD6	5.00 (127)	—
	CFD6	—	5.00 (127)
	NF, HF, LF	5.00 (127)	—
400	JD6, JXD6, HJD6, HJXD6, HHJD6, HHJXD6, CJD6, NJ, HJ, LJ	—	8.75 (222)
		—	6.25 (159)
600	LD6, LXD6, HLD6, HLXD6, HHLD6, HHLXD6, CLD6	—	8.75 (222)
	NL, HL, LL	—	6.25 (159)
800	NM, HM, LM	—	8.75 (222)

¹ Mounting height shown will accommodate from (1) to (6) poles.

² Accessories such as shunt trips on three pole breakers requires 6.25" of unit space

Application

Type P4 Panelboards

Table P4-12 – Branch Breaker Side Gutter Inches (mm) (Fig. P4-3)

Reference Letter	Panel Width 32 in (813) Dimensions in inches (mm)
A	11.0 (279)
B	10.98 (279)
C	8.62 (219)
D	7.0 (178)
E	5.75 (146)
F	5.25 (133)
G	—
H	4.62 (177)
I	8.76 (223)
J	10.42 (265)
K	10.0 (254)
L	8.25 (210)
M	10.0 (254)
N	7.0 (178)
O	5.0 (127)
P	7.50 (191)
Q	7.9 (200)
R	7.9 (200)
S	2.5 (318)
T	11.25 (286)

Fig. P4-3

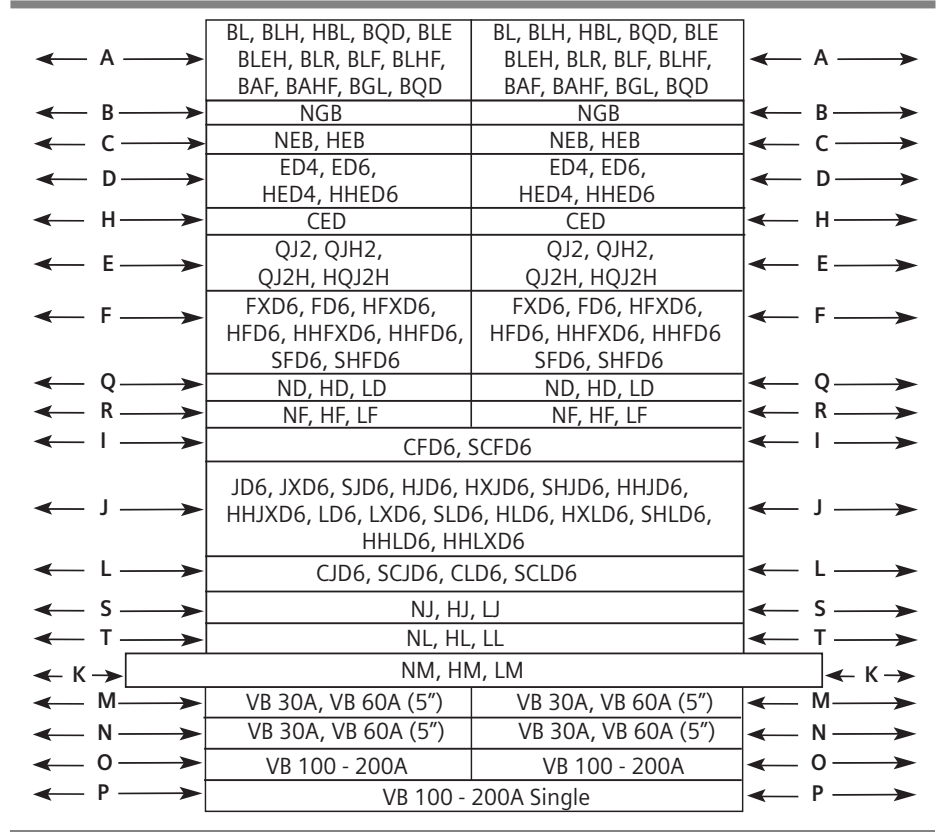

Application

Type P4 Panelboards

Table P4-13 – Main Lugs Only – shown with aluminum bus, top fed, and surface trims

Max. Panel Amp Rating	Unit Space (inches)	208Y/120V	240/120V	120/240V or 250 Vdc Max	240V	480Y/277V	480V ¹
		3 Phase, 4 Wire Catalog Number	3 Phase, 4 Wire Catalog Number	1 Phase, 3 Wire Catalog Number	3 Phase, 3 Wire Catalog Number	3 Phase, 4 Wire Catalog Number	3 Phase, 3 Wire Catalog Number
400	30	P4C60ML400ATS	P4B60ML400ATS	P4A60ML400ATS	P4D60ML400ATS	P4E60ML400ATS	P4F60ML400ATS
	45	P4C75ML400ATS	P4B75ML400ATS	P4A75ML400ATS	P4D75ML400ATS	P4E75ML400ATS	P4F75ML400ATS
	60	P4C90ML400ATS	P4B90ML400ATS	P4A90ML400ATS	P4D90ML400ATS	P4E90ML400ATS	P4F90ML400ATS
600	30	P4C60ML600ATS	P4B60ML600ATS	P4A60ML600ATS	P4D60ML600ATS	P4E60ML600ATS	P4F60ML600ATS
	45	P4C75ML600ATS	P4B75ML600ATS	P4A75ML600ATS	P4D75ML600ATS	P4E75ML600ATS	P4F75ML600ATS
	60	P4C90ML600ATS	P4B90ML600ATS	P4A90ML600ATS	P4D90ML600ATS	P4E90ML600ATS	P4F90ML600ATS
800	30	P4C60ML800ATS	P4B60ML800ATS	P4A60ML800ATS	P4D60ML800ATS	P4E60ML800ATS	P4F60ML800ATS
	45	P4C75ML800ATS	P4B75ML800ATS	P4A75ML800ATS	P4D75ML800ATS	P4E75ML800ATS	P4F75ML800ATS
	60	P4C90ML800ATS	P4B90ML800ATS	P4A90ML800ATS	P4D90ML800ATS	P4E90ML800ATS	P4F90ML800ATS
1000	30	P4C60ML101ATS	P4B60ML101ATS	P4A60ML101ATS	P4D60ML101ATS	P4E60ML101ATS	P4F60ML101ATS
	45	P4C75ML101ATS	P4B75ML101ATS	P4A75ML101ATS	P4D75ML101ATS	P4E75ML101ATS	P4F75ML101ATS
	60	P4C90ML101ATS	P4B90ML101ATS	P4A90ML101ATS	P4D90ML101ATS	P4E90ML101ATS	P4F90ML101ATS
1200	30	P4C60ML120ATS	P4B60ML120ATS	P4A60ML120ATS	P4D60ML120ATS	P4E60ML120ATS	P4F60ML120ATS
	45	P4C75ML120ATS	P4B75ML120ATS	P4A75ML120ATS	P4D75ML120ATS	P4E75ML120ATS	P4F75ML120ATS
	60	P4C90ML120ATS	P4B90ML120ATS	P4A90ML120ATS	P4D90ML120ATS	P4E90ML120ATS	P4F90ML120ATS

Table P4-14 – Main Circuit Breakers Only – shown with standard mains, aluminum bus, top fed, and surface trims

Max. Panel Amp Rating	Unit Space (inches)	208Y/120V	240/120V	120/240V or 250 Vdc Max	240V	480Y/277V	480V ¹
		3 Phase, 4 Wire Catalog Number	3 Phase, 4 Wire Catalog Number	1 Phase, 3 Wire Catalog Number	3 Phase, 3 Wire Catalog Number	3 Phase, 4 Wire Catalog Number	3 Phase, 3 Wire Catalog Number
400	21.25	P4C60JX400ATS	P4B60JX400ATS	P4A60JX400ATS	P4D60JX400ATS	P4E60JX400ATS	P4F60JX400ATS
	36.25	P4C75JX400ATS	P4B75JX400ATS	P4A75JX400ATS	P4D75JX400ATS	P4E75JX400ATS	P4F75JX400ATS
	51.25	P4C90JX400ATS	P4B90JX400ATS	P4A90JX400ATS	P4D90JX400ATS	P4E90JX400ATS	P4F90JX400ATS
600	21.25	P4C60LX600ATS	P4B60LX600ATS	P4A60LX600ATS	P4D60LX600ATS	P4E60LX600ATS	P4F60LX600ATS
	36.25	P4C75LX600ATS	P4B75LX600ATS	P4A75LX600ATS	P4D75LX600ATS	P4E75LX600ATS	P4F75LX600ATS
	51.25	P4C90LX600ATS	P4B90LX600ATS	P4A90LX600ATS	P4D90LX600ATS	P4E90LX600ATS	P4F90LX600ATS
800	21.25	P4C60M1800ATS	P4B60M1800ATS	P4A60M1800ATS	P4D60M1800ATS	P4E60M1800ATS	P4F60M1800ATS
	36.25	P4C75M1800ATS	P4B75M1800ATS	P4A75M1800ATS	P4D75M1800ATS	P4E75M1800ATS	P4F75M1800ATS
	51.25	P4C90M1800ATS	P4B90M1800ATS	P4A90M1800ATS	P4D90M1800ATS	P4E90M1800ATS	P4F90M1800ATS

¹ For 600V, change "F" in position 3 to "G."

Modifications and Additions

P4 Panelboards

Devices Mounted on Gutter Cover

Includes Device, Mounting – Wired or Unwired

Description
One piece front with door
Hinged Gutter Covers 4 pc front
Toggle Switch — SPST or 3-way
15A, 277V maximum
Pilot Light — General Purpose
Neon or Incandescent Pushbutton

Increased Capacity Neutral

Ampere Rating		Unit Space (inches)
Phase	Neutral	
400	600	0
400	800	0
600	1200	0
800	1200	0

Subfeed or Feed-Thru Lugs (One Set Per Panel) Subfeed Double Lugs (Main Lug Panels)

Amp Rating	Unit Spaces (Additional inches)
	MLO
400	0
600	0
800	N/A
1200	N/A

Feed-Thru Lugs

Ampere Rating	Unit Space (inches)
400	10
600	10
800	17.5
1200	17.5

Grounding of Panelboards

Ground Bars (except for brazed-to-box) are shipped with the panel interior factory mounted.

- Non-Insulated Equipment Ground Bar – Standard
- Copper Non-Insulated Ground Bar
- Al Insulated Equipment Ground Bar
- Cu Insulated Equipment Ground Bar
- Ground Bar Brazed to Box

Fuse Clip Provisions (Add to 250 Volts or 600 Volts Unit Prices Per Switch)

Amp Rating	Class J	Class R	Class T
30	•	•	•
60	•	•	•
100	•	•	•
200	•	•	•

Spanner Wrenches (for Vacu-Break Switches)

Ground Fault on Main Breaker

Description	Amp Rating
Conventional Ground Fault ¹ Includes: Ground Fault Relay, Ground Sensor, CPT and Shunt Trip Test and Monitor Panel ²	400-600
Ground Fault add to Sensitrip III breaker price	400-600

Time Clocks ³

Sangamo, Tork or Paragon time clock can be supplied, mounted in panelboard cabinet. For required increase in enclosure dimension, consult local sales office.

Description
Time clock (1- or 2-Pole, Single or Double Throw Contacts; 3-Pole Single Throw)
277V Maximum with Plain Dial
Optional:
Astronomical Dial
An Omitting Device
Reserve Power or Carryover
Space and Mounting Provisions Only

Circuit Breaker Accessories Handle Blocking Device Blocks handle in either the "ON" or "OFF" position.

Padlocking Device – Padlocks in "OFF" position.

Main Bus

Standard main bus and ground bus are tin-plated aluminum. For copper main bus, neutral bus and ground bus, add from the table for each panel.

Lugs – For Main Lug Only Panels

Standard main lugs and neutral lugs are tin-plated aluminum, UL listed for use with aluminum/copper cables. Copper only lugs are an option.

Ampere Rating

400 - 1200

Shunt Trip on Main and Branches ⁴

Description

BL, BQD, NGB (branch only)
All others to 800A HRJ2H, NEB, HEB, ED4, ED6, HED4, HHED6, CED6, QJ2 HQJ2H, QJH2, QJ2H

100% Rated Main Circuit Breakers

Ampere Rating	Breaker Type
400A	JXD6H, HJXD6H
	SCJD6H, SHJD6H
	NJY, HJY, LJY
600A	LXD6H, HLXD6H
	NMY ⁵ , HMY ⁵ , LMY ⁵
800A	MXD6H, HMXD6H, CMD6H
	SMD6H, SHMD6H, SCMD6H

¹ Available in 90" high enclosure only. Unit space is 42 1/2" with Test and Monitor Panel; 45" without Test and Monitor Panel.

² Not available on Sensitrip III.

³ For required unit space, consult local sales office.

⁴ Shunt Trip on 100A frame breakers increases mounting height to 6.25" for twin mounting.

⁵ The 600A, 100% rated breaker requires the use of an 800A frame breaker.

Connector Modifications

P4 Panelboards

Lug Modifications

Table P4-15 – Compression Lugs

Style	Amp Rating	Breaker Type	Compression Connectors	Available Unit Space Reduction
MLO	400	N/A	(1)250 - 500 Kcmil or (2)#2/0 AWG - 250 Kcmil Cu or Al	Deduct 5.0" of Unit Space
	600	N/A	(2)#3/0 AWG - 500 Kcmil	
	800	N/A	(3)#3/0 AWG - 500 Kcmil Cu or Al	
	1000	N/A	(4)#3/0 AWG - 500 Kcmil Cu o Al	
	1200	N/A	(4)#3/0 AWG - 500 Kcmil Cu or Al	
Main Breaker	400	JD6, JXD6, HJD6, HJXD6, HHJD6, HHJXD6, CJD6, SJD6, SHJD6, SCJD6	(2)#2/0 AWG - 500 Kcmil Cu or Al	Deduct 0" of Unit Space
		LD6, LXD6, HLD6, HLXD6, HHLD6, HHLXD6, CLD6, SLD6, SHLD6, SCLD6	(2) #2/0 AWG - 500 Kcmil Cu or Al	Deduct 0" of Unit Space

Table P4-16 – Alternate Lugs

Amp Rating	Breaker Type	Compression Connectors	Available Unit Space Reduction
400	N/A	(1)#3/0 AWG - 750 Kcmil or (2)#3/0 AWG 250 Kcmil Cu or Al	Deduct 2.5" of Unit Space
600	N/A	(2)#3/0 AWG - 750 Kcmil or (4)#3/0 - 350 Kcmil	Deduct 0" of Unit Space
800	N/A	(3)#3/0 AWG - 750 Kcmil Cu or Al	Deduct 5.0" of Unit Space
1200	N/A	(4)#3/0 AWG - 750 Kcmil Cu or Al	Deduct 7.5" of Unit Space

Dimensions

Type P4 Panelboards

Type 1 Box

Box is symmetrical

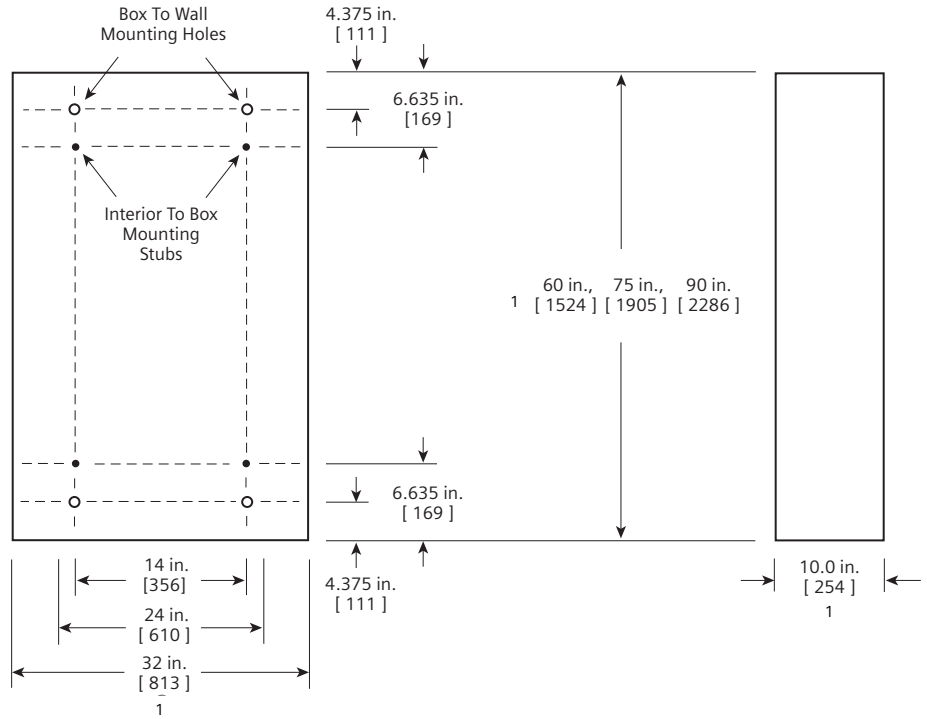
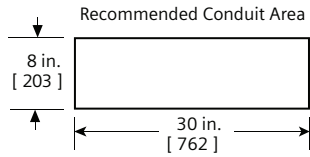

Type 3R and 3R/12 Box

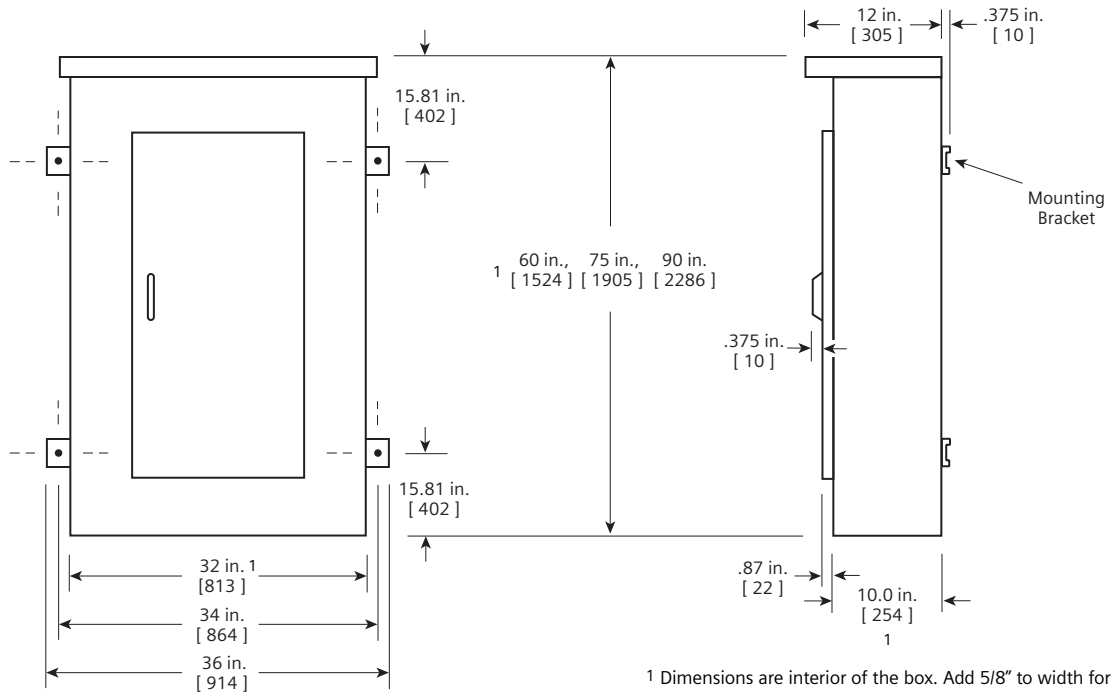

¹ Dimensions are interior of the box. Add 5/8" to width for absolute dimension. Add 1/8" to height for absolute dimension.

Dimensions shown in inches and millimeters [].

Kits and Accessories

Type P4 Panelboards

Table P4-17 – Connector Strap Kits – w/o Circuit Breaker ^{1 2}

For use with Sentron SPP Shallow Depth or Type P4 Power Panels			
Breaker Type	Mounting Type	Unit Height Inches (mm)	Catalog Number
BL, BQD	Twin	3.75 (95)	SBL
NGB	Twin	3.75 (95)	SN
EB	Twin	3.75 (95)	SEB
ED	Twin	3.75 (95)	SE6
CED6	Twin	3.75 (95)	SCE
DG ³	Twin	5.00 (127)	SDG
QJ	Twin	5.00 (127)	SQJ
FG ³	Twin	5.00 (127)	SFG
FD6	Twin	5.00 (127)	SF6
CFD6	Single	5.00 (127)	SCF
JG ³	Single	6.25 (159)	SJG
JD	Single	8.75 (223)	SJ1
SJD	Single	8.75 (223)	SSJ1
CJD6	Single	8.75 (223)	SCJ
SCJD	Single	8.75 (223)	SSCJ
LG ³	Single	6.25 (159)	SLG
LD	Single	8.75 (223)	SL6
SLD	Single	8.75 (223)	SSL6
CLD6	Single	8.75 (223)	SCL
SCLD	Single	8.75 (223)	SSCL
MG ³	Single	8.75 (223)	MG1
LMD	Single	8.75 (223)	SLM1

¹ Includes cover plate and mounting hardware, less circuit breaker.

² Also for use with S4/F4 and SPP/FPP (10" Deep).

³ VL family of circuit breakers.

Table P4-18 – Connecting Strap Kits – Fusible

For use with Sentron Shallow Depth or Type SPP/FPP/F1/P4 power panels		
Ampere Rating	Unit Height Inches (mm)	Catalog Number
30–30	2.5 (63.5)	F602
30–60	5.0 (127), 7.5 (191)	F657
30–60	5.0 (127), 7.5 (191)	F657
60–60	5.0 (127), 7.5 (191)	F657
60–100	5.0 (127), 7.5 (191)	F657
100–100	5.0 (127), 7.5 (191)	F657
100	7.5 (191)	F657
200	7.5 (191)	F657
200	10.0 (254)	F671
200–200	10.0 (254)	F672

**Table P4-19 – Blank Plates
Circuit Breaker and Vacu-Break**

For use with Sentron SPP and Type P4 power panels	
Height Inches (mm)	Catalog Number
1.25 (32)	6FPB01
2.5 (63.5)	6FPB02
3.75 (95)	6FPB03
5.0 (127)	6FPB05
10.0 (254)	6FPB10

Table P4-20 – Filler Plates

For use with Sentron SPP and P4 power panels	
Breaker Type	Filler Plate Catalog Number
BL, BLH, HBL, BQD, NGB, ED2, ED4, ED6 HED4, HHED6,	QF3
NEB, HEB	EBF1

Note: When a front filler plate is not completely filled with breakers, the openings in the unused space must be closed with filler plates selected from this table.

Kits and Accessories

Type P4 Panelboards

Table P4-21 – Enclosures

Description	Catalog number
P4 Type 1 32" W x 10" D x 60" H	PB60
P4 Type 1 32" W x 10" D x 75" H	PB75
P4 Type 1 32" W x 10" D x 90" H	PB90
P4 Type 3R/12 60" H	WP260
P4 Type 3R/12 75" H	WP275
P4 Type 3R/12 90" H	WP290

Table P4-22 – Trims

Description	Catalog number
P4 Std (4 piece trim) vented 60"	P460V
P4 Std (4 piece trim) vented 75"	P475V
P4 Std (4 piece trim) vented 90"	P490V
P4 VBS Std (4 piece trim) vented 60"	P460VV
P4 VBS Std (4 piece trim) vented 75"	P475VV
P4 VBS Std (4 piece trim) vented 90"	P490VV
P4 Std (4 piece trim) unvented 60"	P460NV
P4 Std (4 piece trim) unvented 75"	P475NV
P4 Std (4 piece trim) unvented 90"	P490NV
P4 VBS Std (4 piece trim) unvented 60"	P460NVV
P4 VBS Std (4 piece trim) unvented 75"	P475NVV
P4 VBS Std (4 piece trim) unvented 90"	P490NVV
P4 Std (4 piece trim) vented 60" with hinged gutter covers	P460VHG
P4 Std (4 piece trim) vented 75" with hinged gutter covers	P475VHG
P4 Std (4 piece trim) vented 90" with hinged gutter covers	P490VHG
P4 VBS Std (4 piece trim) vented 60" with hinged gutter covers	P460VVHG
P4 VBS Std (4 piece trim) vented 75" with hinged gutter covers	P475VVHG
P4 VBS Std (4 piece trim) vented 90" with hinged gutter covers	P490VVHG
P4 Std (4 piece trim) unvented 60" with hinged gutter covers	P460NVHG
P4 Std (4 piece trim) unvented 75" with hinged gutter covers	P475NVHG
P4 Std (4 piece trim) unvented 90" with hinged gutter covers	P490NVHG
P4 VBS Std (4 piece trim) unvented 60" with hinged gutter covers	P460NVVHG
P4 VBS Std (4 piece trim) unvented 75" with hinged gutter covers	P475NVVHG
P4 VBS Std (4 piece trim) unvented 90" with hinged gutter covers	P490NVVHG
P4 Std (1 PC Door) vented 60"	P460VD
P4 Std (1 PC Door) vented 75"	P475VD
P4 Std (1 PC Door) vented 90"	P490VD
P4 Std (1 PC Door) unvented 60"	P460NVD
P4 Std (1 PC Door) unvented 75"	P475NVD
P4 Std (1 PC Door) unvented 90"	P490NVD
P4 Std (1 PC Door-in-door) vented 60"	P460VDD
P4 Std (1 PC Door-in-door) vented 75"	P475VDD
P4 Std (1 PC Door-in-door) vented 90"	P490VDD
P4 Std (1 PC Door-in-door) unvented 60"	P460NVDD
P4 Std (1 PC Door-in-door) unvented 75"	P475NVDD
P4 Std (1 PC Door-in-door) unvented 90"	P490NVDD

Table P4-23 – Flush mounting kits

Description	Catalog number
Flush kit for P4 60" High	F60
Flush kit for P4 75" High	F75
Flush kit for P4 90" High	F90

Notes



P5 Panelboards

Description	Page	Typical Catalog Numbers	
General Information	5-2	Main Lugs Only	5-9
Selection and Application	5-2	Main Circuit Breakers Only	5-9
Application	5-3 – 5-8	Main Fusible Switch	5-9
Main Breaker Selection	5-3	Modifications and Additions	5-10 – 5-12
Enclosure Selection	5-4	Motor Starters	5-11 – 5-12
Main Breaker and Main Switch	5-3 – 5-4	Connector Modifications	5-12
Main Switch Connectors	5-4	Compression Lugs	5-12
Main Lugs Only Unit Space	5-5	Alternate Lugs	5-12
Branch Switch Unit Space	5-5	Dimensions	5-13
Branch Circuit Breakers	5-6	Kits and Accessories	5-14 – 5-15
Branch Breaker Unit Space	5-7		
Branch Breaker Side Gutters	5-8		

Type P5 Panelboards

The P5 panel is the largest distribution panel in the Siemens panel family. Even so, the P5 panel is still a space saver with its 38" width and 12.75" depth. With even higher main ratings to fit the application that require more or larger branch devices. This panel offers a wide array of factory assembled options and enables users to mix breaker frames in unit space up to 1200 amps and fusible switches up to 1200 amps. Bussing options for the P5 vary from the standard temperature rated aluminum to temperature rated copper and 750 A/Si aluminum and 1000A/Si copper designs. All aluminum bussing in the P5 panel is tin-plated as a standard. All copper bus is silver plated. Integrated time clocks, bus mounted contactors as mains or submains, split bus and subfeed lugs (up to 600 amps) are just a few of the options of this flexible panel.

P5 panel configurations are defined by the unit space allowed for a given amperage, main device and box height. The P5 panel starts with a 60" high box. All branch devices are unit space mounted. Breakers and switches can be mixed and matched to meet customer requirements.

Main Lug / Main Breaker / Main Switch

Enclosure – Standard Type 1 enclosure is 38" wide x 12.75" deep. X Box Height is determined by main device and unit space. See charts for box height.

Voltage – 600 Vac Max.
250 Vdc Max.

Amperage – 400-1200 amp Main breaker, 400-1200 amp MLO
200-1200 amp Main switch.

Short Circuit Rating – 200 KAIC Max. symmetrical or equal to the lowest rated device installed unless a series rating is indicated. Panels with subfeed or feed-thru lugs without a main device, circuit breaker or fusible unit, are limited to a three-cycle rating. The three-cycle rating for the P5 panel is limited to 42 KAIC. Note that the main device may be mounted remote from the panel.

Bussing – The P5 panel has more options to meet market requirements. The standard bussing is temperature rated aluminum. The rating is per the requirements of UL 67 – the standard for panelboards. All aluminum bussing is tin-plated. Optional bussing for the P5 panel is: 750 A/Si aluminum, temperature rated copper, and 1000 A/Si copper. The copper bus option for this panel is silver-plated.

Weight – Approximate

Total panelboard weight when filled with a normal quantity of breakers and accessories is about 10 lbs. (1 kg) per inch (54g per mm) of box height.

Table P5-1 – Main Lugs ¹

Ampere Rating	Connectors Suitable for Copper or Aluminum
800	(3) - #3/0 AWG-600 Kcmil
1000	(4) - #3/0 AWG-600 Kcmil
1200	(4) - #3/0 AWB-600 Kcmil

¹ Alternate lugs for 750 Kcmil cable are available, but result in significant loss of branch unit mounting space. Consult Siemens.

Table P5-2 – Gauge Steel of Boxes Fronts, Surface and Flush

Dimensions in inches (mm)		Gauge Steel	
Width	Height	Box	Fronts
38"	60 - 75 - 90	#16 ¹	#12 (1 piece trim)
(965)	(1524, 1905, 2286)		#12 ² (4 piece trim)

¹ 16 gauge side panels, 12 gauge back support.
² 10 gauge gutter covers, 16 gauge vent covers.

Selection and Application

1) To specify a particular panelboard, first determine voltage, system, amperage and type of main, amperage and type of branch devices, and modifications, if any. (Step 1)

2) List branch devices and modifications requiring space additions. List unit space requirements of each.

Note: Some units are twin mounted meaning two breakers occupy the same unit space.

Select appropriate enclosure height from selection chart on page 5-3 based on unit space requirements. (Step 2)

3) Select panelboard catalog number from appropriate table based upon voltage, system, amperage and unit space requirements. (Step 3)

Step #1

Amperage	1200
Voltage	208Y/120
System	3 Phase, 4 wire
Main	Main Breaker
Branches	5-125/3, 2-225/3, 1-250/3
Modifications	None
Feed	Top
Mounting	Surface

Step #2

5-125/3 NGB	3.75" = 11.25"	Twin Mounted
2-225/3 QJ2	5" = 5"	Twin Mounted
1-250/3 FXD6	5" = 5"	
	21.25	
Enclosure is B875 from Selection Chart on Page 5-3. (32" wide, 75" high, 10" deep)		

Step #3

1-P5C75NI120ATS
5-125/3 NGB
3-NGB 1 Pole Provision
2-225/3 QJ2
1-250/3 FXD6
1-FXD6 Prov. 13.25" Space

Application

Type P5 Panelboards

Table P5-3 – Main Breaker Selection

Ampere rating	Breaker type			Maximum IC (KA) Symmetrical Amperes				Available Trip Values
	Trip type	Frame type	Breaker family	240V	480V	600V	Main Breaker Unit Space in inches (mm)	
400A	TMTU ¹	JXD6 (STD), JD6	Sentron	65	35	22	8.75 (222)	200, 225, 250, 300, 350, 400
		HJXD6, HJD6	Sentron	100	65	35	8.75 (222)	200, 225, 250, 300, 350, 400
		HHJXD6, HHJD6	Sentron	200	100	50	8.75 (222)	200, 225, 250, 300, 350, 400
		CJD6	Sentron	200	150	100	8.75 (222)	200, 225, 250, 300, 350, 400
	ETU ¹	NJ	VL	65	35	25	6.25 (159)	250, 400
		SJD6	Sentron	65	35	25	8.75 (222)	200, 300, 400
		HJ	VL	100	65	25	6.25 (159)	250, 400
		SHJD6	Sentron	100	65	35	8.75 (222)	200, 300, 400
		LJ	VL	200	100	25	6.25 (159)	250, 400
		SCJD6	Sentron	200	150	100	8.75 (222)	200, 300, 400
600A	TMTU	LXD6 (STD)	Sentron	65	35	25	8.75 (222)	450, 500, 600
		LD6	Sentron	65	35	25	8.75 (222)	250, 300, 350, 400, 450, 500, 600
		HLXD6, HHL6	Sentron	100	65	35	8.75 (222)	250, 300, 350, 400, 450, 500, 600
		HHLXD6, HHL6	Sentron	200	100	50	8.75 (222)	250, 300, 350, 400, 450, 500, 600
		CLD6	Sentron	200	150	100	8.75 (222)	250, 300, 350, 400, 450, 500, 600
	ETU	NL ²	VL	65	35	18	6.25 (159)	400, 600
		SLD6	Sentron	65	35	25	8.75 (222)	300, 400, 500, 600
		HL ²	VL	100	65	18	6.25 (159)	400, 600
		SHLD6	Sentron	100	65	35	8.75 (222)	300, 400, 500, 600
		LL ²	VL	200	100	18	6.25 (159)	400, 600
	SCLD6	Sentron	200	150	100	8.75 (222)	300, 400, 500, 600	
800A	TMTU	NM ³ (STD)	VL	65	35	25	8.75 (222)	600, 700, 800
		MXD6, MD6	Sentron	65	50	25	10 (254)	500, 600, 700, 800
		LMXD6, LMD6	Sentron	100	65	35	8.75 (222)	600, 700, 800
		HM ³	VL	100	65	35	8.75 (222)	600, 700, 800
		HMXD6, HMD6	Sentron	100	65	50	10 (254)	500, 600, 700, 800
	ETU	HLMXD6, HLMD6	Sentron	200	100	50	8.75 (222)	600, 700, 800
		LM ³	VL	200	100	50	8.75 (222)	600, 700, 800
		CMD6	Sentron	200	100	65	10 (254)	500, 600, 700, 800
		NM ³	VL	65	35	25	8.75 (222)	600, 800
		SMD6	Sentron	65	50	25	10 (254)	600, 700, 800
1200A	TMTU	HM ³	VL	100	65	35	8.75 (222)	600, 800
		SHMD6	Sentron	100	65	50	10 (254)	600, 700, 800
		HM ³	VL	200	100	50	8.75 (222)	600, 800
		SCMD6	Sentron	200	100	65	10 (254)	600, 700, 800
		NN (STD)	VL	65	35	25	10 (254)	800, 900, 1000, 1200
	ETU	NXD6	Sentron	65	50	25	10 (254)	900, 1000, 1200
		HN	VL	100	65	35	10 (254)	800, 900, 1000, 1200
		HNXD6, HND6	Sentron	100	65	50	10 (254)	900, 1000, 1200
		LN	VL	200	100	65	10 (254)	800, 900, 1000, 1200
		CND6	Sentron	200	100	65	10 (254)	900, 1000, 1200
ETU	NN	VL	65	35	25	10 (254)	800, 1000, 1200	
	SND6	Sentron	65	50	25	10 (254)	800, 1000, 1200	
	HN	VL	100	65	35	10 (254)	800, 1000, 1200	
	SHND6	Sentron	100	65	50	10 (254)	800, 1000, 1200	
	LN	VL	200	100	65	10 (254)	800, 1000, 1200	
	SCND6	Sentron	200	100	65	10 (254)	800, 1000, 1200	

¹ TMTU = Thermal Magnetic Trip Unit and ETU = Electronic Trip Unit.

² 100% ratings are not available for the VL LG frame, replace with VL MG frame @ 600A rated 100%.

³ 100% ratings are not available for the VL MG. Use a VL NG frame @ 800A trip rated 100%.

Application

Type P5 Panelboards

Table P5-4 – Enclosure Selection¹

Enclosure Dimension in Inches (mm)				Available Unit Space in inches (mm) Dimension "C" in Fig. P5-1		
H	W	D		Main Lug only 800 / 1200A	Main Breaker 800 / 1200A	Main Switch 800 / 1200A
		Type 1	Type 3R/12			
60 (1524)	38 (965)	12.75 (324)	14.25 (362)	30 (762)	20 (508)	13.75 (349)
75 (1905)	38 (965)	12.75 (324)	14.25 (362)	45 (1143)	35 (889)	28.75 (730)
90 (2286)	38 (965)	12.75 (324)	14.25 (362)	60 (1524)	50 (1270)	43.75 (1111)

¹ Standard trim is four piece without door. Surface or flush one piece trim is available for 32 in. (813 mm) wide circuit breaker panels.

Table P5-5 – Main Breaker Lug Location Reference (Fig. P5-1)

Ampere Rating	Breaker Type	Dimensions in inches (mm)	
		A	B
400	JXD6, JD6, HJXD6, HJD6, HHJXD6, HHJD6	13.425 (265)	13.125 (333)
400	NJ, HJ, LJ	15.500 (318)	
400	SJD6, SHJD6	13.425 (265)	
400	CJD6, SCJD6	11.250 (210)	
600	LXD6, LD6, HLXD6, HLD6, HHLXD6, HHLD6	13.425 (265)	
600	NL, HL, LL	14.250 (286)	
600	SLD6, SHLD6	13.425 (265)	
600	CLD6, SCLD6	11.250 (210)	
800	NM, HM, LM	13.425 (265)	
800	MXD6, MD6, HMXD6, HMD6, CMD6, SMD6, SHMD6, SCMD6	13.00 (330) 10.42 (265)	
1200	NN, HN, LN	13.425 (265)	
1200	NXD6, ND6, HNXD6, HMD6, CND6, SND6, SHMD6, SCND6	13.00 (330) 13.00 (330)	

Fig. P5-1

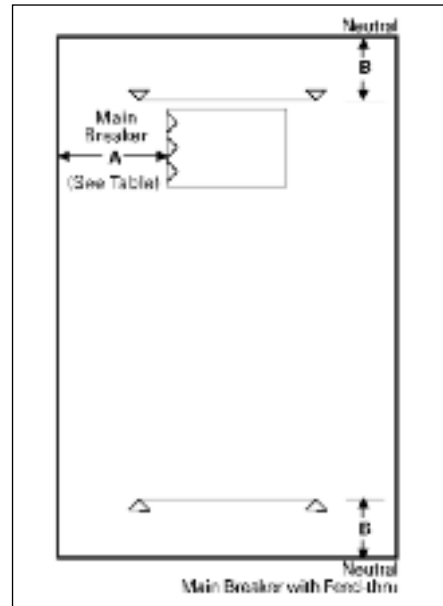

Table P5-6 – Main Switch Lug Location Reference (Fig P5-1)

Ampere Rating	Breaker Type	Dimensions in inches (mm)	
		A	B
200	VB	13.425 (265)	13.125 (333)
400/600	VB	15.500 (318)	
400/1200	HCP	13.425 (265)	

Table P5-7 Main Switch Connectors

Ampere Rating	Connectors Suitable for Copper or Aluminum
200	(1) #6 AWG - #3/0 AWG
400	(1) #3/0 - 500KCMIL (2) #3/0 - 250KCMIL
600	(2) #3/0 - 500KCMIL
800	(3) #3/0 - 500KCMIL
1200	(4) #3/0 - 500KCMIL

Application

Type P5 Panelboards

Table P5-8 – Main Lugs Only Unit Space (Fig. P5-2)

Lugs	Dimensions in inches (mm)					
	Main Lug					Neutral
	400A A	600A B	800A C	1000A D	1200A E	800A G
Standard	16.500 (419)	16.750 (425)	15.969 (406)	15.969 (406)	15.969 (406)	13.125 (333)
Oversize	16.500 (419)	21.750 (552)	25.969 (660)	25.969 (660)	25.969 (660)	23.125 (587)
Crimp	19.187 (487)	18.250 (484)	18.687 (475)	18.250 (464)	18.250 (464)	15.937 (405)
Standard with Subfeed	16.750 (425)	15.969 (406)	—	—	—	13.125 (333)
Standard with Feed-thru	16.500 (419)	16.750 (425)	—	—	—	13.125 (333)

Fig. P5-2

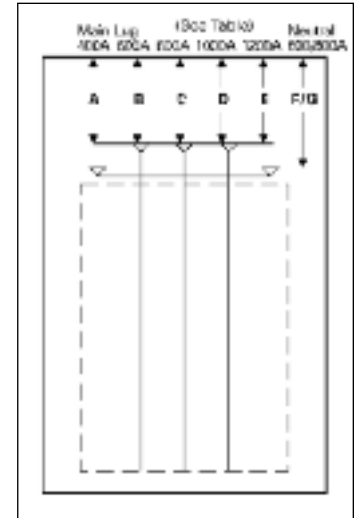

Table P5-9 – Branch Switch Unit Space

Ampere Rating	Number of Poles	Unit Space in Inches (mm)		AC Voltage	Cables Per Connector	Connectors Suitable For Copper or Aluminum
		Twin Mounted	Single Mounted			
30-30	2, 3	2.50 (64)	—	240	1	#14 - #8 AWG (Cu Only)
30-30	2, 3	5.00 (127)	—	240	1	#14 - #4 AWG
30-60	2, 3	5.00 (127)	—	240	1	#14 - #4 AWG
60-60	2, 3	5.00 (127)	—	240	1	#14 - #4 AWG
60-100	2, 3	7.50 (191)	—	240	1	#10 - #1/0 AWG
100-100	2, 3	7.50 (191)	—	240	1	#10 - #1/0 AWG
200-200	3	10.00 (254)	—	240	1	#6 AWG - 350 Kcmil
200	2	—	7.50 (191)	240	1	#6 AWG - 350 Kcmil
200	3	—	10.00 (254)	240	2	#6 AWG - 350 Kcmil
400	2, 3	—	15.00 (381)	240	2	#4/0 AWG - 500 Kcmil
600	2, 3	—	15.00 (381)	240	2	#4/0 AWG - 500 Kcmil
30-30	2, 3	7.50 (191)	—	600	1	#14 - #4 AWG
30-60	2, 3	7.50 (191)	—	600	1	#14 - #4 AWG
60-60	2, 3	7.50 (191)	—	600	1	#14 - #4 AWG
60-100	2, 3	7.50 (191)	—	600	1	#10-#1/0 AWG
100-100	2, 3	7.50 (191)	—	600	1	#10-#1/0 AWG
200-200	3	10.00 (254)	—	600	1	#6 AWG - 350 Kcmil
100	2, 3	—	7.50 (191)	600	1	#10 - #1/0 AWG
200	2, 3	—	10.00 (254)	600	2	#6 AWG - 350 Kcmil
400	2, 3	—	15.00 (381)	600	2	#4/0 AWG - 500 Kcmil
600	2, 3	—	15.00 (381)	600	2	#4/0 AWG - 500 Kcmil
800	2, 3	—	16.25 (413)	600	3	#3/0 AWG - 500 Kcmil
1200	2, 3	—	16.25 (413)	600	4	#3/0 AWG - 500 Kcmil

Application

Type P5 Panelboards

Table P5-10 – Branch Circuit Breakers

Maximum Ampere Rating	Bolt-on Breaker Type	Number of Poles	Trip Amp Rating	Maximum IC (KA) Symmetrical Amperes							
				Voltage – AC							
				120	120/240	240	277	480/ 277	480	600/347	600
100	BLF	1	15-30	10	—	—	—	—	—	—	—
		2	15-60	—	10	—	—	—	—	—	—
	BLHF	1	15-30	22	—	—	—	—	—	—	—
		2	15-60	—	22	—	—	—	—	—	—
	BLE	1	15-30	10	—	—	—	—	—	—	—
		2	15-60	—	10	—	—	—	—	—	—
	BLEH	1	15-30	22	—	—	—	—	—	—	—
		2	15-60	—	22	—	—	—	—	—	—
	BAF, BAFC	1	15-20	10	—	—	—	—	—	—	—
	BAFH, BAFHC	1	15-20	22	—	—	—	—	—	—	—
	BAF	2	15-20	—	10	—	—	—	—	—	—
	BAFH	2	15-20	—	22	—	—	—	—	—	—
	BGL	2	15-30	10	—	—	—	—	—	—	—
		3	15-30	—	10	—	—	—	—	—	—
	BLR (240V)	2	15-100	—	—	10	—	—	—	—	—
	BL	1	15-70	10	—	—	—	—	—	—	—
		2	15-100	—	10	—	—	—	—	—	—
		3	15-100	—	—	10	—	—	—	—	—
	BLH	1	15-70	—	22	—	—	—	—	—	—
		2	15-100	—	22	—	—	—	—	—	—
		3	15-100	—	—	22	—	—	—	—	—
	HBL	1	15-70	—	65	—	—	—	—	—	—
		2	15-100	—	65	—	—	—	—	—	—
		3	15-100	—	—	65	—	—	—	—	—
	BQD	1	15-70	—	65	—	14	—	—	—	—
		2	15-100	—	65	—	—	14	—	—	—
		3	15-100	—	—	65	—	14	—	—	—
	BQD6 ¹	1	15-70	65	—	—	—	—	—	—	—
2		15-100	—	—	65	—	—	—	—	10	
3		15-100	—	—	65	—	—	—	—	10	
BL (HID)	1/2	15-30	—	10	—	—	—	—	—	—	
BLF (GFCI)	1	15-60	—	10	—	—	—	—	—	—	
	2	40-60	—	10	—	—	—	—	—	—	
BLE (EQ GFI)	1/2	15-30	—	10	—	—	—	—	—	—	
BGL (SWN)	2	15-30	10	—	—	—	—	—	—	—	
	3	15-30	—	10	—	—	—	—	—	—	
BLHF (GFCI)	1/2	15-30	—	22	—	—	—	—	—	—	
125	NGB	1	15-125	100	—	—	25	—	—	—	—
		2/3	15-125	—	100	100	—	25	—	14	—
	NEB	1	15-125	100	85	85	35	—	—	—	—
		2/3	15-125	—	85	85	—	35	35	22	—
	HEB	1	15-125	200	100	100	65	—	—	—	—
		2/3	15-125	—	100	100	—	65	65	25	—
	ED4	1	15-125	65	—	—	22	—	—	—	—
		2/3	15-125	—	65	65	—	18	18	—	—
	ED6	2	15-125	—	—	—	—	25	25	30	—
		3	15-125	—	—	65	—	25	25	—	18
	HED4	1	15-125	100	—	—	65 ²	—	—	—	—
		2/3	15-125	—	100	100	—	42	42	—	—
HHED6	2/3	15-125	100	—	—	—	65	65	18	18	
CED6	2/3	15-125	200	—	—	—	—	200	200	100	100
225	QJ2	2/3	60-225	—	—	10	—	—	—	—	—
	QJH2	2/3	60-225	—	—	22	—	—	—	—	—
	QJ2H	2/3	60-225	—	—	42	—	—	—	—	—
	HQJ2H	2/3	60-225	—	—	100	—	—	—	—	—
250	FXD6, FD6	2/3	70-250	—	—	65	—	35	35	18	18
	HFXD6, HFD6	2/3	70-250	—	—	100	—	65	65	25	25
	HHFXD6, HHFD6	2/3	70-250	—	—	200	—	100	100	25	25
	CFD6	2/3	70-250	—	—	200	—	200	200	100	100
400	JXD6, JD6, SJD6	2/3	200-400	—	—	65	—	35	35	25	25
	HJXD6, HJD6, SHJD6	2/3	200-400	—	—	100	—	65	65	35	35
	HHJXD6, HHJD6	2/3	200-400	—	—	200	—	100	100	50	50
	CJD6, SCJD6	2/3	200-400	—	—	200	—	150	150	100	100
600	LXD6	2/3	450-600	—	—	65	—	35	35	25	25
	LD6	2/3	250-600	—	—	65	—	35	35	25	25
	SLD6	2/3	300-600	—	—	65	—	35	35	25	25
	HLD6, HLXD6	2/3	250-600	—	—	100	—	65	65	35	35
	SULD6	2/3	300-600	—	—	100	—	65	65	35	35
	HULD6, HHLXD6	2/3	250-600	—	—	200	—	100	100	50	50
	CLD6	2/3	450-600	—	—	200	—	150	150	100	100
	SULD6	2/3	300-600	—	—	200	—	150	150	100	100

¹ CSA listed only at 600V AC.

² 15-30A trip (shown) 65 kA, 35-100A 25 kA.

Application

Type P5 Panelboards

Table P5-11 – Branch Breaker Circuit Breakers (VL)

Ampere Rating	Maximum Breaker Type	Number of Poles	Trip Amp Rating	Maximum IC (KA) Symmetrical Amperes							
				Voltage – AC							
				120	120/250	240	277	480/277	480	600/347	600
150 ¹	ND	3	60-150	—	65	65	—	35	35	18	18
	HD	3	60-150	—	100	100	—	65	65	20	20
	LD	3	60-150	—	200	200	—	100	100	25	25
250 ¹	NF	3	100-250	—	65	65	—	35	35	18	18
	HF	3	100-250	—	100	100	—	65	65	20	20
	LF	3	100-250	—	200	200	—	100	100	25	25
400 ¹	NJ	3	250-400	—	65	65	—	35	35	25	25
	HJ	3	250-400	—	100	100	—	65	65	25	25
	LJ	3	250-400	—	200	200	—	100	100	25	25
600 ¹	NL	3	400-600	—	65	65	—	35	35	18	18
	HL	3	400-600	—	100	100	—	65	65	18	18
	LL	3	400-600	—	200	200	—	100	100	18	18
800	NM	2/3	600-800	—	65	65	—	35	35	25	25
	HM	2/3	600-800	—	100	100	—	65	65	35	35
	LM	2/3	600-800	—	200	200	—	100	100	50	50
1200	NN	2/3	800-1200	—	65	65	—	35	35	25	25
	HN	2/3	800-1200	—	100	100	—	65	65	35	35
	LN	2/3	800-1200	—	200	200	—	100	100	50	50

¹ Only available with Electronic Trip Units.

Table P5-12 – Branch Breakers Unit Space Requirements

Amp Rating	Breaker Type	Mounting Height in Inches (mm)	
		Twin	Single
100 ¹	BL,BLH,HBL,BQD,BLE, BLEH, BLR, BLF, BLHF, BAF, BAFC, BAFH, BAFCH, BGL	3.75 (95) ¹	—
	BL, BLH, HBL, BQD -With accessories	6.25 (159)	
125	NGB, NEB, HEB, ED4, ED6, HED4, HHED6, CED6	3.75 (95) ¹	—
	NGB, ED4 ^{1,2} , ED6 ^{1,2} , HED4 ^{1,2} , HHED6 ^{1,2} , CED6 ^{1,2} (With accessories)	6.25 (159)	
150	ND, HD, LD	5.00 (127)	—
225	QJ2, QJH2, QJ2H, HQJ2H	5.00 (127)	—
250	NF, HF, LF	5.00 (127)	—
	FD6, FXD6, HFD6, HFXD6, HHFD6, HHFXD6	5.00 (127)	—
	CFD6	—	5.00 (127)
400	NJ, HJ, LJ	—	6.25 (159)
	JD6, JXD6, HJD6, HJXD6, HHJD6, HHJXD6, CJD6	—	8.75 (222)
600	NL, HL, LL	—	6.25 (159)
	LD6, LXD6, HLD, HLXD6, HHLD6, HHLXD6, CLD6	—	8.75 (222)
800	NM, HM, LM	—	8.75 (222)
	MXD6, MD6, HMXD6, HMD6, CMD6	—	10.00 (254)
1200	NN, HN, LN	—	10.00 (254)
	NXD6, ND6, HNXD6, HND6, CND6	—	10.00 (254)

¹ Mounting height shown will accommodate from (1) to (6) poles.

² Accessories such as shunt trips on three pole breakers requires 6.25" of unit space.

Application

Type P5 Panelboards

Table P5-13 – Branch Breaker Side Gutter

Reference Letter	Panel Width – 32 (813) Dimensions in inches (mm)
A	14.0 (356)
B	13.98 (355)
C	11.62 (295)
D	10.0 (254)
E	7.61 (193)
F	8.75 (222)
G	8.25 (210)
H	10.90 (276)
I	10.90 (276)
J	11.76 (299)
K	7.92 (201)
L	8.0 (203)
M	13.42 (341)
N	12.0 (305)
O	15.50 (393)
P	14.25 (362)
Q	13.42 (341)
R	13.42 (341)
S	10.0 (254)
T	8.0 (203)
U	10.50 (267)
V	10.50 (267)
W	9.30 (236)
X	10.30 (262)
Y	9.30 (236)
Z	10.30 (262)

Fig. P5-3

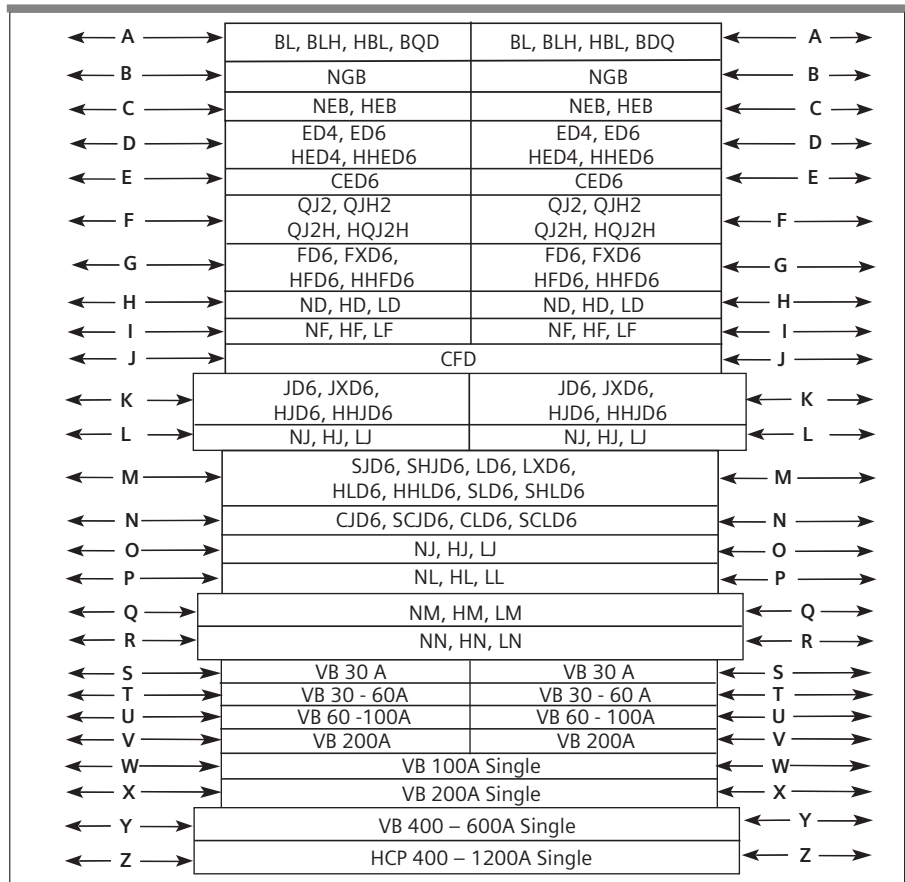

Typical Catalog Numbers

Type P5 Panelboards

Table P5-14 – Main Lugs Only – shown with aluminum bus, top fed, and surface trims

Max. Panel Amp Rating	Unit Space (inches)	208Y/120V	240/120V	120/240V or 250 Vdc Max	240	480Y/277V	480V ¹
		3 Phase, 4 Wire Catalog Number	3 Phase, 4 Wire Catalog Number	1 Phase, 3 Wire Catalog Number	3 Phase, 3 Wire Catalog Number	3 Phase, 4 Wire Catalog Number	1 Phase, 3 Wire Catalog Number
800	30	P5C60ML800ATS	P5B60ML800ATS	P5A60ML800ATS	P5D60ML800ATS	P5E60ML800ATS	P5F60ML800ATS
	45	P5C75ML800ATS	P5B75ML800ATS	P5A75ML800ATS	P5D75ML800ATS	P5E75ML800ATS	P5F75ML800ATS
	60	P5C90ML800ATS	P5B90ML800ATS	P5A90ML800ATS	P5D90ML800ATS	P5E90ML800ATS	P5F90ML800ATS
1000	30	P5C60ML101ATS	P5B60ML101ATS	P5A60ML101ATS	P5D60ML101ATS	P5E60ML101ATS	P5F60ML101ATS
	45	P5C75ML101ATS	P5B75ML101ATS	P5A75ML101ATS	P5D75ML101ATS	P5E75ML101ATS	P5F75ML101ATS
	60	P5C90ML101ATS	P5B90ML101ATS	P5A90ML101ATS	P5D90ML101ATS	P5E90ML101ATS	P5F90ML101ATS
1200	30	P5C60ML120ATS	P5B60ML120ATS	P5A60ML120ATS	P5D60ML120ATS	P5E60ML120ATS	P5F60ML120ATS
	45	P5C75ML120ATS	P5B75ML120ATS	P5A75ML120ATS	P5D75ML120ATS	P5E75ML120ATS	P5F75ML120ATS
	60	P5C90ML120ATS	P5B90ML120ATS	P5A90ML120ATS	P5D90ML120ATS	P5E90ML120ATS	P5F90ML120ATS

Table P5-15 – Main Circuit Breakers – shown with aluminum bus, top fed, and surface trims

Max. Panel Amp Rating	Unit Space (inches)	208Y/120V	240/120V	120/240V or 250 Vdc Max	240	480Y/277V	480V ¹
		3 Phase, 4 Wire Catalog Number	3 Phase, 4 Wire Catalog Number	1 Phase, 3 Wire Catalog Number	3 Phase, 3 Wire Catalog Number	3 Phase, 4 Wire Catalog Number	1 Phase, 3 Wire Catalog Number
800	21.25	P5C60M1800ATS	P5B60M1800ATS	P5A60M1800ATS	P5D60M1800ATS	P5E60M1800ATS	P5F60M1800ATS
	36.25	P5C75M1800ATS	P5B75M1800ATS	P5A75M1800ATS	P5D75M1800ATS	P5E75M1800ATS	P5F75M1800ATS
	51.25	P5C90M1800ATS	P5B90M1800ATS	P5A90M1800ATS	P5D90M1800ATS	P5E90M1800ATS	P5F90M1800ATS
1200	20	P5C60N1120ATS	P5B60N1120ATS	P5A60N1120ATS	P5D60N1120ATS	P5E60N1120ATS	P5F60N1120ATS
	35	P5C75N1120ATS	P5B75N1120ATS	P5A75N1120ATS	P5D75N1120ATS	P5E75N1120ATS	P5F75N1120ATS
	50	P5C90N1120ATS	P5B90N1120ATS	P5A90N1120ATS	P5D90N1120ATS	P5E90N1120ATS	P5F90N1120ATS

Table P5-16 – Main Fusible Switch (fuses not included)

Max. Panel Amp Rating	Unit Space (inches)	208Y/120V	240/120V	120/240V	240V	480Y/277V	480V ¹
		3 Phase, 4 Wire Catalog Number	3 Phase, 4 Wire Catalog Number	1 Phase, 3 Wire Catalog Number	3 Phase, 3 Wire Catalog Number	3 Phase, 4 Wire Catalog Number	3 Phase, 3 Wire Catalog Number
400	20	P5C75MS400ATS	P5B75MS400ATS	P5A75MS400ATS	P5D75MS400ATS	P5E75MS400ATS	P5F75MS400ATS
	40	P5C90MS400ATS	P5B90MS400ATS	P5A90MS400ATS	P5D90MS400ATS	P5E90MS400ATS	P5F90MS400ATS
600	25	P5C75MS600ATS	P5B75MS600ATS	P5A75MS600ATS	P5D75MS600ATS	P5E75MS600ATS	P5F75MS600ATS
	40	P5C90MS600ATS	P5B90MS600ATS	P5A90MS600ATS	P5D90MS600ATS	P5E90MS600ATS	P5F90MS600ATS
800 ²	28.75	P5C75MS800ATS	P5B75MS800ATS	P5A75MS800ATS	P5D75MS800ATS	P5E75MS800ATS	P5F75MS800ATS
	43.75	P5C90MS800ATS	P5B90MS800ATS	P5A90MS800ATS	P5D90MS800ATS	P5E90MS800ATS	P5F90MS800ATS
1200 ²	28.75	P5C75MS120ATS	P5B75MS120ATS	P5A75MS120ATS	P5D75MS120ATS	P5E75MS120ATS	P5F75MS120ATS
	43.75	P5C90MS120ATS	P5B90MS120ATS	P5A90MS120ATS	P5D90MS120ATS	P5E90MS120ATS	P5F90MS120ATS

¹ For 600V, change "F" in position 3 to "G."

² Alternate main breaker requires an additional 1.25" unit space.

Modification and Additions

Type P5 Panelboards

Devices Mounted on Gutter Cover

Includes Device, Mounting – Wired or Unwired

Description
One piece front with door (Depth increases to 14.25")
Hinged Gutter Covers 4 pc front
Toggle Switch — SPST or 3-way 15A, 277V maximum
Pilot Light — General Purpose Neon or Incandescent
Pushbutton

Feed-Thru Lugs

Ampere Rating	Unit Space (inches)
400	10
600	10
800	17.5
1200	17.5

Grounding of Panelboards

Ground Bars except for brazed to box are shipped with the panel interior factory mounted.

- Non-Insulated Equipment Ground Bar – Standard
- Copper Non-Insulated Ground Bar
- Al Insulated Equipment Ground Bar
- Cu Insulated Equipment Ground Bar
- Ground Bar Brazed to Box

Fuse Clip Provisions (Add to 250 Volts or 600 Volts Unit Prices Per Switch)

Amp Rating	Class J	Class R	Class T
30	•	•	N/A
60	•	•	N/A
100	•	•	•
200 ¹	•	•	•
400	•	•	•
600	•	•	•

Ground Fault on Main Breaker

Description	Amp Rating
Conventional Ground Fault ² Includes: Ground Fault Relay, Ground Sensor, CPT and Shunt Trip	800-1200
Test and Monitor Panel ³ Ground Fault add to Sensitrip III breaker price (takes 5" of unit space)	800-1200

•Indicates available

Time Clocks⁴

Sangamo, Tork or Paragon time clock can be supplied, mounted in panel-board cabinet. For required increase in enclosure dimension, consult local sales office.

Description
Time clock (1- or 2-Pole, Single or Double Throw Contacts; 3-Pole Single Throw) 277V Maximum with Plain Dial
Options:
Astronomical Dial
An Omitting Device
Reserve Power or Carryover
Space and Mounting Provisions Only

Circuit Breaker Accessories Handle Blocking Device Blocks handle in either the "ON" or "OFF" position.

Padlocking Device – Padlocks in "OFF" position.

Main Bus

Standard main bus and ground bus are tin-plated aluminum. For copper main bus, neutral bus and ground bus, add from the table for each panel.

Lugs – For Main Lug Only Panels

Standard main lugs and neutral lugs are tin-plated aluminum, UL listed for use with aluminum/copper cables. Copper only lugs are an option.

Ampere Rating
400 - 1200

Shunt Trip on Main and Branches⁵

Description
BL, BQD, NGB, NEB, HEB (branch only)
QJ2, QJH2, QJ2H, ED2, ED4, HED4, HQJ2H, HHED6, CED6 (branch only)
All others through 1200A

100% Rated Main Circuit Breakers

Ampere Rating	Breaker Type
	JXD6H, HJXD6H
400	NJY, HJY, LJY
600	LXD6H, HLXD6H
600 ⁶	NMY, HMY, LMY
800 ⁷	NNY, HNY, LNY
1200	NNY, HNY, LNY

¹ For use on main lug, main breaker or main switch panels without subfeed breakers.

² Available in 90" high enclosure only. Unit space is 42 1/2" with Test and Monitor Panel; 45" without Test Monitor Panel.

³ Not available on Sensitrip III.

⁴ For required unit space, consult local sales office.

⁵ Shunt Trip on 100A frame breakers increases mounting height to 6.25" for twin mounting.

⁶ The 600A, 100% rated breaker application requires the use of an 800A frame breaker.

⁷ The 800A, 100% rated breaker application requires the use of a 1200A frame breaker.

Modification and Additions

Type P5 Panelboards

Motor Starters

ETI instantaneous-trip circuit breakers are recommended for use in combination motor starters to provide selective short circuit protection for the motor branch circuit. The adjustable instantaneous-trip feature provides a trip setting slightly above the peak motor inrush current. With this setting, there is no delay opening the circuit when the fault occurs. Since these circuit breakers have no time delay trip element, they must be used in conjunction with, and immediately ahead of, the motor-running over-current protective device.

Check the voltage and interrupting rating of the circuit breaker to ensure they are adequate for the electrical system. UL recognized ETI breakers must be used.

Full voltage, non-reversing NEMA Size 1 through Size 4 motor starters are available as additions to P5 panelboards. P5 panelboards can accommodate motor

disconnect devices in either one of two circumstances: 1. by using a branch thermal magnetic (ETI) circuit breaker to feed a remote starter that controls a motor which is in sight of and within fifty feet of the panelboard. 2. by using a branch instantaneous trip only (ETI) circuit breaker in conjunction with a motor starter mounted in the same enclosure which is in sight of and within fifty feet of the controlled motor.

Whether a remote starter is used, or the breaker and starter are mounted in the same enclosure, a padlocking device must be specified so a padlock can be installed in the "OFF" position. P2 panelboards incorporate motor disconnect devices much in the same way as P5 panelboards, except a fusible Vacu-Break switch unit is utilized rather than an ETI circuit breaker. In addition, padlocking devices are standard on all Vacu-Break switches eliminating the need to order them as an accessory.

Standard Motor Starters Equipped With:

- 3rd overload relay
- Mechanical interlock between circuit breaker (or switch) and motor starter door
- Reset button
- Class 1, Type A wiring

Optional Motor Control Accessories

- Pushbuttons: Start/Stop or Open/Close, Reverse/Forward/Stop or High/Low/Stop
- Selector Switch: Hand/Off/Auto or On/Off
- Pilot Light: Red or Amber
- Auxiliary interlock (normally open or normally closed-unwired)
- Control transformer, 60Hz, fused LV, Sizes 1 thru 4
- Class 1, Type B wiring

Table P5-17 – ETI circuit Breakers (Instantaneous Trip Only) For Branch-Circuit Use with AC Full Voltage Motor Starters

Amp Rating	Breaker Type	Maximum 3Ø Ratings			Mounting Height in Inches (mm)		
		220 (208)V	240V	480V ^{1 2}	Twin	Single	Min. Section Width Inches (mm)
3		—	—	1	5 (127)	—	32 (813)
5		0.5	0.5	2	5 (127)	—	32 (813)
10	ED ¹	2	2	3	5 (127)	—	32 (813)
25		5	5	10	5 (127)	—	32 (813)
50		15	15	30	5 (127)	—	32 (813)
100		30	30	60	5 (127)	—	32 (813)
150	FD6 ²	40	40	75	5 (127)	—	32 (813)
225	FD6, CFD6	50	50	100	5 (127)	—	32 (813)

¹ 100,000 kA at 480V with E-frame and CFD6 frame breakers.

² 65,000 kA at 480V with F-frame breakers.

³ Increase to 7.50 inches when pilot light or control transformer is required.

Table P5-18 – Full Voltage Non-Reversing Starters Class A20

NEMA Starter Size	Unit Space Mtg. Ht. In. (mm)	
	Left	Right
0	—	5 (127) ³
0	0	5 (127) ³
1	—	5 (127) ³
1	0	5 (127) ³
1	1	5 (127) ³
2	—	10 (254)
2	0	10 (254)
2	1	10 (254)
2	2	10 (254)
3	—	15 (381)
3	0	15 (381)
3	1	15 (381)
3	2	15 (381)
3	3	15 (381)
4	—	15 (381)

Table P5-19 – Maximum 3 Phase Horsepower Rating

NEMA Starter Size	Voltage AC		
	220 (208)V	240V	480V
0	3	3	5
1	7.5	7.5	10
2	10	15	25
3	25	30	50
4	40	50	100

Modification and Additions

Type P5 Panelboards

**Table P5-20 – Vacu-Break Fusible Switches
For Branch Circuit Use with AC Combination Full Voltage Starters ¹**

Amp Rating	Horsepower Ratings				Mounting Height in Inches (mm)				Min. Section Width Inches (mm)
	240V AC		480V AC		240V AC		480V AC		
	With NEC Fuse	With Dual-Element Fuse	With NEC Fuse	With Dual-Element Fuse	Twin	Single	Twin	Single	
30-30	3	7.5	—	—	2.50 ² (64)	—	—	—	32 (813)
30-30	3	7.5	5	10	5.00 (127)	—	7.50 (191)	—	32 (813)
30-60	3-7.5	7.5-15	5-15	25	5.00 (127)	—	7.50 (191)	—	32 (813)
60-60	7.5	15	15	25	5.00 (127)	—	7.50 (191)	—	32 (813)
60-100	7.5-15	15-30	15-25	25-50	7.50 (191)	—	7.50 (191)	—	32 (813)
100-100	15	30	25	50	7.50 (191)	—	7.50 (191)	—	32 (813)
100	—	—	25	50	—	—	—	7.50 (191)	32 (813)
200	25	50	50	100	—	10.00 (254)	—	10.00 (254)	32 (813)
200-200	—	50	—	100	10.00 (254)	—	10.00 (254)	—	32 (813)
400	50	100	100	—	—	15.00 (381)	—	15.00 (381)	38 (965)
600	75	100	—	—	—	15.00 (381)	—	15.00 (381)	38 (965)

¹ 100,000 kA at 480V with Class J or Class RK5 fuses.

² The 2.50 inch (64mm) high unit is suitable for NEC Class H and K5 fuses only. Class R rejection type fuse holders are not available.

Connector Modifications

Compression Lugs

Table P5-21 – Compression Lugs

Style	Amp Rating	Breaker Type	Compression Connectors	Available Unit Space Reduction
MLO	800	N/A	All compression lugs	Deduct 10.0" Unit Space
	1000	N/A	All compression lugs	Deduct 10.0" Unit Space
	1200	N/A	All compression lugs	Deduct 10.0" Unit Space
Main Breaker	800	MD6, HMD6, CMD6, SMD6, SHMD6, SCMD6	(3)#2/0 AWG - 500 Kcmil CU or Al	0
	1200	ND6, HND6, CND6, SND6, SHND6, SCND6	(4)#250 - 500 Kcmil Cu or Al	0

Table P5-22 – Alternate Lugs

Style	Amp Rating	Breaker Type	Compression Connectors	Available Unit Space Reduction
MLO	800	N/A	(3)#3/0 AWG - 750 Kcmil Cu or Al	Deduct 5.0" Unit Space
	1000	N/A	(4)#3/0 AWG - 750 Kcmil Cu or Al	Deduct 7.5" Unit Space
	1200	N/A	(4)#3/0 AWG - 750 Kcmil CU or Al	Deduct 7.5" Unit Space

Dimensions

Type P5 Panelboards

Type 1 Box

Box is symmetrical

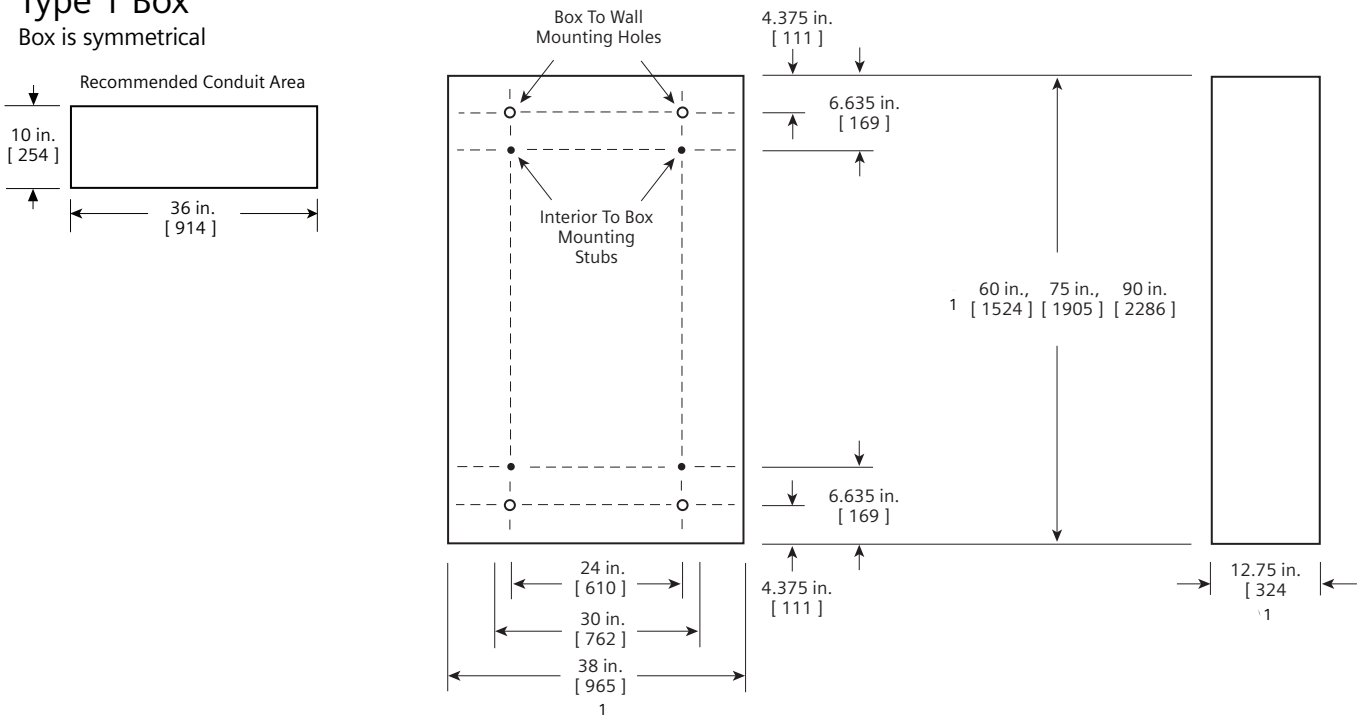

Type 3R and 3R/12 Box

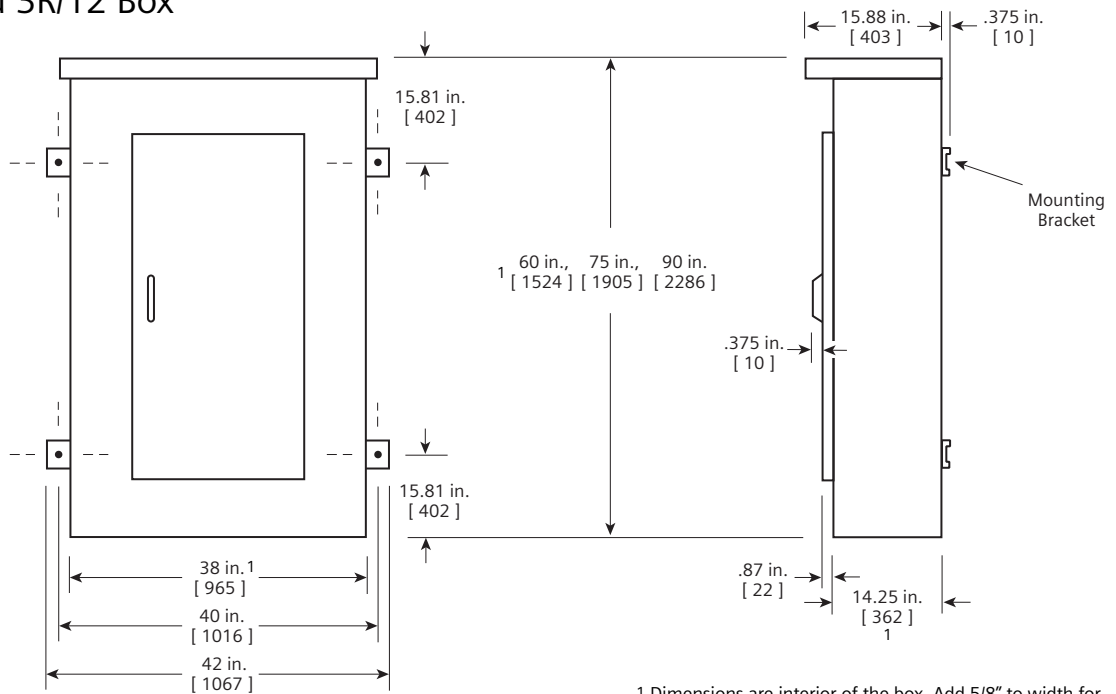

1 Dimensions are interior of the box. Add 5/8" to width for absolute dimension. Add 1/8" to height for absolute dimension.

Dimensions shown in inches and millimeters [].

Kits and Accessories

Type P5 Panelboards

Table P5-23 – Branch Breaker Connecting Strap Kits ^{1 2}

For use with Sentron Deep or Type P5 power panels			
Breaker Type	Mounting Type	Unit Height Inches (mm)	Catalog Number
BL, BQD	Twin	3.75 (95)	SBLBD
NGB	Twin	3.75 (95)	SNBD
NEB, HEB	Twin	3.75 (95)	SEBD
ED	Twin	3.75 (95)	SE6D
CED	Twin	3.75 (95)	SCED
DG ⁴	Twin	5.00 (127)	SDGD
QJ	Twin	5.00 (127)	SQJD
FD	Twin	5.00 (127)	SF6D
FG ⁴	Twin	5.00 (127)	SFGD
CFD	Single	5.00 (127)	SCFD
JD6	Single	8.75 (223)	SJ1D
	Twin		SJ2D
SJD6	Single	8.75 (222)	SSJ1D
JG ^{4 5}	Single	6.25 (159)	SJG1D
	Twin		SJG2D
CJD	Single	8.75 (222)	SCJD
SCJD	Single	8.75 (222)	SSCJD
LD6	Single	8.75 (222)	SL6D
SLD	Single	8.75 (222)	SSL6D
LG ⁴	Single	6.25 (159)	SLGD
CLD	Single	8.75 (222)	SCLD
SCLD	Single	8.75 (222)	SSCLD
MG ⁴	Single	8.75 (222)	MG1D
LMD6	Single	8.75 (222)	SLM1D
MD6, CMD6	Single	10.00 (254)	SMND
SMD6	Single	10.00 (254)	SSMND
NG ⁴	Single	10.00 (254)	NG1D
ND6	Single	10.00 (254)	SMND
SND6	Single	10.00 (254)	SSMND

Table P5-26 – Connecting Strap Kits – Fusible ³

For use with Sentron FPP Deep or Type F2/P5 power panels		
Ampere Rating	Unit Height Inches (mm)	Catalog Number
30–30	2.5 (63.5)	F602D
30–30	5.0 (127), 7.5 (191)	F657D
30–60	5.0 (127), 7.5 (191)	F657D
60–60	5.0 (127), 7.5 (191)	F657D
60–100	5.0 (127), 7.5 (191)	F657D
100–100	5.0 (127), 7.5 (191)	F657D
100	7.5 (191)	F657D
200	7.5 (191)	F657D
200	10.0 (254)	F671D
200–200	10.0 (254)	F672D
400–600	15.0 (381)	F6150D
800–1200 ²	16.25 (413)	F6162D

¹ Includes cover plate and mounting hardware, less circuit breaker.

² Also fits Types FCI, FCII, SB1, SB2 and SB3 switchboards.

³ 800-1200 amp units are HCP switch.

⁴ VL family of circuit breakers.

⁵ JG ETU are not viewable when twin mounted.

Table P5-24 – Blank Plates – Circuit Breaker and Vacu-Break ¹

For use with Sentron SPP and Type P5 power panels	
Height Inches (mm)	Catalog Number
1.25 (32)	6FPB01
2.5 (63.5)	6FPB02
3.75 (95)	6FPB03
5.0 (127)	6FPB05
10.0 (254) ⁴	6FPB10

Table P5-25 – Filler Plates

For use with Sentron SPP and P5 power panels	
Breaker Type	Filler Plate Catalog Number
BL, BLH, HBL, BQD, NGB	
ED2, ED4, ED6	QF3
HED4, HHED6	
NEB, HEB	EBF1

Note: When a front filler plate is not completely filled with breakers, the openings in the unused space must be closed with filler plates selected from this table.

Kits and Accessories

Type P5 Panelboards

Table P5-27 – Enclosures

Description	Catalog number
P5 Type 1 38" W x 12.75" D x 60" H	PB860
P5 Type 1 38" W x 12.75" D x 75" H	PB875
P5 Type 1 38" W x 12.75" D x 90" H	PB890
P5 Type 1 38" W x 14.75" D x 60" H	PBD860 ¹
P5 Type 1 38" W x 14.75" D x 75" H	PBD875 ¹
P5 Type 1 38" W x 14.75" D x 90" H	PBD890 ¹
P5 Type 3R/12 60" H	WP860
P5 Type 3R/12 75" H	WP875
P5 Type 3R/12 90" H	WP890

¹ Required with door over breaker handles.

Table P5-28 – Trims

Description	Catalog number
P5 Std (4 piece trim) vented 60"	P560V
P5 Std (4 piece trim) vented 75"	P575V
P5 Std (4 piece trim) vented 90"	P590V
P5 Std (4 piece trim) unvented 60"	P560NV ¹
P5 Std (4 piece trim) unvented 75"	P575NV ¹
P5 Std (4 piece trim) unvented 90"	P590NV ¹
P5 Std (4 piece trim) vented 60" with hinged gutter covers	P560VHG
P5 Std (4 piece trim) vented 75" with hinged gutter covers	P575VHG
P5 Std (4 piece trim) vented 90" with hinged gutter covers	P590VHG
P5 Std (4 piece trim) unvented 60" with hinged gutter covers	P560NVHG
P5 Std (4 piece trim) unvented 75" with hinged gutter covers	P575NVHG
P5 Std (4 piece trim) unvented 90" with hinged gutter covers	P590NVHG
P5 Std (1 PC Door) vented 60"	P560VD ²
P5 Std (1 PC Door) vented 75"	P575VD ²
P5 Std (1 PC Door) vented 90"	P590VD ²
P5 Std (1 PC Door) unvented 60"	P560NVD ²
P5 Std (1 PC Door) unvented 75"	P575NVD ²
P5 Std (1 PC Door) unvented 90"	P590NVD ²
P5 Std (1 PC Door-in-door) vented 60"	P560VDD ²
P5 Std (1 PC Door-in-door) vented 75"	P575VDD ²
P5 Std (1 PC Door-in-door) vented 90"	P590VDD ²
P5 Std (1 PC Door-in-door) unvented 60"	P560VDD ²
P5 Std (1 PC Door-in-door) unvented 75"	P575VDD ²
P5 Std (1 PC Door-in-door) unvented 90"	P590VDD ²

¹ Unvented trims require amps per square inch bussing.

² Requires 14.5" deep box.

Table P5-29 – Flush mounting kits

Description	Catalog number
Flush kit to P5 60" High	F860
Flush kit to P5 75" High	F875
Flush kit to P5 90" High	F890

Notes



C1/C2 Panelboards

Description	Page		
General Specifications	6-2	Subfeed Breakers C1	6-4
Box Sizing	6-2	Alternate Main Breaker Selection C2	6-5
Gauge Steel Boxes	6-2	Branch Circuit Breaker C2	6-5
Fronts	6-2	Subfeed Breakers C2	6-5
Main Breaker Connectors	6-2	Modification and Additions	6-6
Main Lug Connectors	6-2	Box Modifications	6-6
Selection	6-3 – 6-5	Interior Modifications	6-6
Main Lugs Only C1 and C2	6-3	Column Extension	6-6
Main Circuit Breaker C1 and C2	6-3	Pull Boxes	6-6
Alternate Main Breaker Selection C1	6-3		
Branch Breaker Selection C1	6-4		

General Specifications

C1 and C2 Panelboards

Type C1

250 Volts AC Maximum
 250 Ampere Mains
 250 Ampere Maximum Branch
 UL Short Circuit Rating – 200,000 IR Maximum
 Branch Breaker Symmetrical Interrupting Rating
 Based on Underwriters' Test Procedure

Type C2

480Y/277 Volts AC Maximum
 250 Ampere Mains
 250 Ampere Maximum Branch
 UL Short Circuit Rating – 100,000 IR Maximum
 Meets 2002 NEC wire bending requirement, section 312-6

Panelboards

Listed by Underwriter's Laboratories, Inc., under "Panelboards"
 File #E2269

Meets Federal Specification W-C375B/Gen.

Panelboards Fronts and Doors

Standard panelboards are furnished with trim with a flush door lock. All are factory assembled for ease of installation. Fronts are fabricated from code gauge steel and finished ANSI-61.

Main Breakers C1

BL, BLH and HBL frame breakers are mounted horizontally. All other frames are mounted vertically.

Main Breakers C2

BQD frame breakers are mounted horizontally. All other frames are mounted vertically.

Weight — Approximate

Total panelboard weight when filled with a normal quantity of breakers and accessories is about 3 lbs. (1 kg) per inch (54g per mm) of box height.

Column Extensions

Available in various standard lengths, extensions are 5.25 in. (133 mm) deep with a width of 7 in. (178 mm). (These are outside dimensions). Designed to fit into an 8 in. (203 mm) structural WF beam. Column panels may also be surface mounted.

Pull Boxes

Two styles of pull boxes are available, top and front mounted. When the panel and its extensions are mounted in a structural WF Beam, a front-mounted pull box is required. When the panels are surface-mounted, top-mounted pull box may be used. Provisions are made so that the neutral bar may be mounted in the pull box when required.

Table C1/C2-1 – Box Sizing

Certain Modifications such as subfeed breakers and feed-thru lugs require additional unit space. Use this table to determine proper enclosure size.

Panel Configuration	No. of Circuits	Height Inches (mm)	Dimensions in inches (mm)			
			Width		Depth	
			C1	C2	C1	C2
Main Lug	18	48 (1219)	7.62 (194)	8.50 (216)	5.75 (146)	5.75 (146)
	30	73 (1854)				
	42	85 (2159)				
Main Lug with Feed-Thru Lugs	18	73 (1854)				
	30	86 (2184)				
	42	85 (2159)				
Main Lug with Subfeed Breaker	18	73 (1854)				
	30	85 (2159)				
	42	85 (2159)				
Main Breaker	18	48 (1219)				
	30	73 (1854)				
	42	85 (2159)				
Main Breaker with Feed-Thru Lugs	18	73 (1854)				
	30	85 (2159)				
	42	85 (2159)				
Main Breaker with Subfeed Breaker	18	73 (1854)				
	30	85 (2159)				

Table C1/C2-2 – Gauge Steel Boxes

Type	Width	Height	Gauge Steel
C1	7 5/8"	48, 73, 85	#14
C2	8 1/2"	48, 73, 85	#14

Table C1/C2-3 – Fronts

Type	Width	Height	Gauge Steel
C1	7 5/8"	48, 73, 85	#14
C2	8 1/2"	48, 73, 85	#14

Table C1/C2-4 – Main Breaker Connectors

Ampere Rating	Connector Suitable for Cu or Al
100	(1) #14-1/0 AWG
125	(1) #4-1/0 AWG
225	(1) #6 AWG-300 kcmil
250	(1) #4 AWG-350 kcmil Al (1) #6 AWG-350 kcmil Cu

Table C1/C2-5 – Main Lug Connectors

Ampere Rating	Connector Suitable for Cu or Al
125	(1) #6 AWG-350 kcmil
250	(1) #6 AWG-350 kcmil

Selection

C1 and C2 Panelboards

Table C1/C2-6 – Main Lugs Only C1

Max. Panel Amp Rating	Max. 1-Pole Circuits	Box Height Inches	208Y/120V 3, Phase 4 Wire Catalog Number	120/240V 1 Phase, 3 Wire Catalog Number
125	18	48	C1C18ML125CTS	C1A18ML125CTS
	30	73	C1C30ML125CTS	C1A30ML125CTS
	42	85	C1C42ML125CTS	C1A42ML125CTS
250	18	48	C1C18ML250CTS	C1A18ML250CTS
	30	73	C1C30ML250CTS	C1A30ML250CTS
	42	85	C1C42ML250CTS	C1A42ML250CTS

Table C1/C2-7 – Main Lugs Only C2

Max. Panel Amp Rating	Max. 1-Pole Circuits	Box Height Inches	480Y/277V 3 Phase, 4 Wire Catalog Number
125	18	48	C2E18ML125CTS
	30	73	C2E30ML125CTS
	42	85	C2E42ML125CTS
250	18	48	C2E18ML250CTS
	30	73	C2E30ML250CTS
	42	85	C2E42ML250CTS

Table C1/C2-8 – Main Circuit Breaker C1 ^{1 2}

Amp Rating	Box Height Inches	Max. 1-Pole Circuits	Catalog Number	Catalog Number
100	18	48	C1C18BL100CTS	C1A18BL100CTS
	30	73	C1C30BL100CTS	C1A30BL100CTS
	42	85	C1C42BL100CTS	C1A42BL100CTS
125	18	48	C1C18E4125CTS	C1A18E4125CTS
	30	73	C1C30E4125CTS	C1A30E4125CTS
	42	85	C1C42E4125CTS	C1A42E4125CTS
225	18	48	C1C18QJ225CTS	C1A18QJ225CTS
	30	73	C1C30QJ225CTS	C1A30QJ225CTS
	42	85	C1C42QJ225CTS	C1A42QJ225CTS
250	18	48	C1C18FX250CTS	C1A18FX250CTS
	30	73	C1C30FX250CTS	C1A30FX250CTS
	42	85	C1C42FX250CTS	C1A42FX250CTS

Table C1/C2-9 – Main Circuit Breaker C2 ^{1 2}

Amp Rating	Box Height Inches	Max. 1-Pole Circuits	Catalog Number
100	18	48	C2E18BD100CTS
	30	73	C2E30BD100CTS
	42	85	C2E42BD100CTS
125	18	48	C2E18E4125CTS
	30	73	C2E30E4125CTS
	42	85	C2E42E4125CTS
225	18	48	C2E18FX225CTS
	30	73	C2E30FX225CTS
	42	85	C2E42FX225CTS
250	18	48	C2E18FX250CTS
	30	73	C2E30FX250CTS
	42	85	C2E42FX250CTS

Table C1/C2-10– Alternate Main Breaker Selection C1 ^{1 2}

Amp Rating	Breaker Type	Maximum Interrupting Rating (KA)	Catalog Number	Available Trip Values
100	BL	10	BL	50, 60, 70, 80, 90, 100
	BLH	22	LH	
	HBL	65	HL	
125	ED4	65	E4	50, 60, 70, 80, 90, 100, 110, 125
	HED4	100	H4	
225	QJ2	10	QJ	60, 70, 80, 90, 100, 110, 125, 150, 175, 200, 225
	QJH2	22	QH	
	QJ2-H	42	Q2	
	FXD6	65	FX	
250	HFD6 ²	100	HF	70, 80, 90, 100, 110, 125, 150, 175, 200, 225
	FXD6	65	FX	
	HFD6 ²	100	HF	

¹ BL, BLH, HBL and BQD are horizontally mounted. All others vertically mounted.

² Interchangeable trip breakers such as FD6 and HFD6 cannot be back fed. Must be top feed only.

Selection

C1 and C2 Panelboards

Table C1/C2-11 – Branch Breaker Selection C1

Breaker Type	Available Ampere Rating	Maximum Interrupting Rating (kA)		
		120V	120/240V	240V
BL (120V)	15, 20, 30, 40, 50, 60	—	10	—
	70	—	10	—
	70, 80, 90, 100	—	10	—
BL (HID)	15, 20, 30	—	—	—
BLF (GFCI)	15, 20, 30	10	—	—
	40, 50, 60	10	—	—
BLE (EQGFI)	15, 20, 30	10	—	—
BGL (SWN)	15, 20, 30	10	—	—
	15, 20, 30	—	10	—
BLR (240V)	15, 20, 30, 40, 50, 60	—	—	10
	70, 80, 90, 100	—	—	10
BLH (120V)	15, 20, 30, 40, 50, 60	—	22	—
	70	—	22	—
	70, 80, 90, 100	—	22	—
BLHF (GFCI)	15, 20, 30	—	22	—
	40, 50, 60	—	22	—
HBL	15, 20, 30, 40, 50	—	65	65
	60, 70, 80, 90, 100	—	65	65
BQD	15, 20, 30, 40, 50, 60	—	—	65
	70, 80, 90, 100	—	—	65

Table C1/C2-12 – Subfeed Breakers - Limit One Per Panel – C1

ED4	15, 20, 30, 40, 50, 60, 70, 80, 90, 100	—	—	65
	110, 125	—	—	65
HED4	15, 20, 30, 40, 50, 60, 70, 80, 90, 100	—	—	65
	110, 125	—	—	100
QJ2	60, 70, 80, 90, 100, 110, 125, 150, 175, 200, 225	—	—	10
QJH2	60, 70, 80, 90, 100, 110, 125, 150, 175, 200, 225	—	—	22
QJ2-H	60, 70, 80, 90, 100, 110, 125, 150, 175, 200, 225	—	—	42
FXD6	70, 80, 90, 100, 110, 125, 150, 175, 200, 225, 250	—	—	65
HFD6	70, 80, 90, 100, 110, 125, 150, 175, 200, 225, 250	—	—	100

Selection

C1 and C2 Panelboards

Table C1/C2-13 – Alternate Main Breaker Selection^{1 2 3} C2

Ampere Rating	Breaker Type	IR	Catalog Number	Available Trip Values
100	BQD	14	BD	50, 60, 70, 80, 90, 100
	ED4	18	E4	50, 60, 70, 80, 90, 100
	ED6	25	E6	50, 60, 70, 80, 90, 100
	HED4	42	H4	50, 60, 70, 80, 90, 100
	HHED6	65	H6	50, 60, 70, 80, 90, 100
125	ED4	18	E4	110, 125
	ED6	25	E6	110, 125
	HED4	42	H4	110, 125
	HHED6	65	H6	110, 125
225	FXD6	35	FX	70, 80, 90, 100, 110, 125, 150, 175, 200, 225
	HFD6	65	HF	70, 80, 90, 100, 110, 125, 150, 175, 200, 225
250	FXD6	35	FX	250
	HFD6	65	HF	250

¹ No increase in box height. Space is already built into C1 panel.

² BL, BLH, HBL and BQD are horizontally mounted. All others vertically mounted.

³ Interchangeable trip breakers such as FD6 and HFD6 cannot be back fed. Must be top feed only.

Table C1/C2-14 – Branch Circuit Breakers C2

Breaker Type	Available Ampere Rating	Maximum Interrupting Rating (kA)		
		277V	480/277V	480V
BQD	15, 20, 30, 40, 50, 60	14	14	—
	70, 80, 90, 100	14	14	—

Table C1/C2-15 – Subfeed Breakers - Limit One Per Panel^{1 2} C2

ED4	15, 20, 30, 40, 50, 60, 70, 80, 90, 100	—	18	18
	110, 125	—	18	18
ED6	15, 20, 30, 40, 50, 60, 70, 80, 90, 100	—	—	25
	110, 125	—	—	25
HED4	15, 20, 30, 40, 50, 60, 70, 80, 90, 100	—	—	42
	110, 125	—	—	42
FXD6	70, 80, 90, 100, 110, 125, 150, 175, 200, 225, 250	—	—	35
HFD6	70, 80, 90, 100, 110, 125, 150, 175, 200, 225, 250	—	—	65

¹ No increase in box height. Space is already built into C1 panel.

² BL, BLH, HBL and BQD are horizontally mounted. All others vertically mounted.

Modification and Additions

C1 and C2 Panelboards

Type C1/C2

When required, special constructions or additions to standard panelboards may be specified for factory-assembled column panelboards.

Table C1/C2-16 – Box Modifications

Description
Gasketed
Metal Card Holder
Welded Metal Card Holder
Nameplate
Al Ground Bar
Cu Ground Bar
Insulated Al Ground Bar
Insulated Cu Ground Bar

Table C1/C2-17 – Interior Modifications

Description
Feed-Thru Lugs
Handle Blocking Devices – BL, BQD
Handle Blocking Devices – QJ, FD6
Handle Padlocking Devices – BL, BQD
Handle Padlocking Devices – QJ, FD6
Shunt Trip – BL, BQD
Shunt Trip – ED Frame, QJ
Shunt Trip – FD6
Cu Neutral Lugs
Cu Main Lugs 125A
Cu Main Lugs 250A

Column Extension

Available in various standard lengths, extensions are 5 ¼ inches deep and 7 inches wide.

Table C1/C2-18 – Column Extension

Height (inches)	Catalog Number
14	LXX-14
20	LXX-20
26	LXX-26
32	LXX-32
38	LXX-38
41	LXX-41
44	LXX-44
53	LXX-53
56	LXX-56
62	LXX-62
65	LXX-65
68	LXX-68
74	LXX-74
80	LXX-80
86	LXX-86

Pull Boxes

Two styles of pull boxes are available, top and front mounted. When the panel and its extensions are mounted in a structural WF beam, a front mounted pull box is required. When the panels are surface mounted, a top mounted pull box may be used. Provisions are made so that the neutral bar may be mounted in the pull box when required. (Front mounted pull box dimensions are 14" H x 20" W.)

Table C1/C2-19 – Pull Boxes

Description	Catalog Number
Top Mount	LXXP-T
Front Mount ¹	LXX50-F

¹ Includes 50" extension.

Fig. C1/C2-1

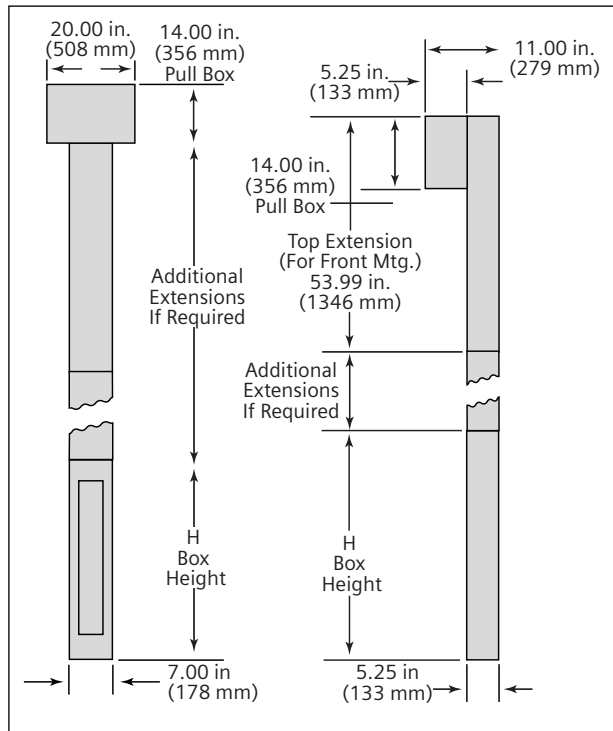



Miscellaneous

Description	Page	
Telephone Cabinets	7-2	Strap Kits 7-4
Conduit Enclosing Shield (Panel Skirts)	7-2	Connecting Strap Kits 7-4
Breaker Mechanical Lugs	7-2	Blank Plates – Vacu-Break 7-4
Compression Lugs	7-2	Molded Case Lugs 7-4
Optional Mechanical Lugs	7-3	
Aluminum Body Lugs for Copper or Aluminum Wire	7-3	
Miscellaneous Replacement Parts	7-4	

Miscellaneous

Telephone Cabinets

Conform to requirements of Underwriter's Laboratories, Inc., for all cabinets and boxes bearing their label. Surface enclosures, box and front constructed of code gauge steel. Entire cabinet finished with light gray, ANSI-61. Flush enclosures, box constructed of code-gauge galvanized steel, front only finished with light gray, ANSI-61.

Boxes

Standard construction has blank ends, without knockouts.

Front

Concealed hinges standard on fronts. Double doors supplied when door width exceeds 24 in. (610 mm). 3-point catch

and vault handle supplied with double doors; two spring catches supplied on doors more than 48 in. (1219 mm) high.

Table Misc.- 1

Box Width – In. (mm)	Door
0 (0)–20 (508)	Single
21 (533)–24 (610)	Single
25 (635)–36 (914)	Single
25 (635)–36 (914)	Double
37 (940)–38 (965)	Double
49 (1245)–60 (1524)	Double

All available with 0.75 in. (19 mm) backboard. Depth 12 in. (305 mm) or less. Height 72 in. (1829 mm) or less. Specify Mounting – Surface or Flush. Box width minus 5 in. (127 mm) equals door width.

Backboard

0.75 in. (19mm) plywood backboard supplied when specified.

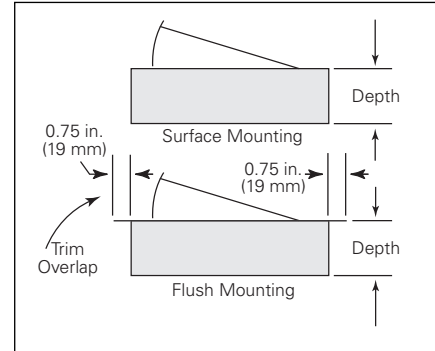

Conduit Enclosing Shield (Panel Skirts)

Sheet metal to cover conduits above or below a standard panelboard box.

Panel Skirts Standard Length

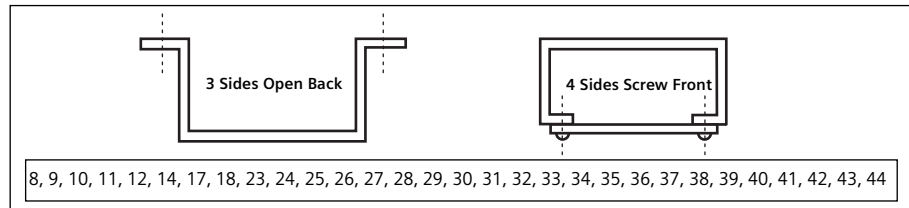

Table Misc. 2 – Compression Lugs

For Circuit Breaker Types	Ampere Rating	Poles	Lugs Per Kit	Lug Wire Size
Lugs (contains indicated number of lugs and necessary hardware per kit)				
ED2, ED4, ED6, HED4, HHED6, CED4	15-125	1,2,3	1	#2/0
QJ2, QJH2, QJ2-H	125-225	2, 3	1	350 kcmil
F(X)D6-A, HF(X)D6, HHF(X)D6, CFD6	125-250	2, 3	1	350 Kcmil
JXD2-A, J(X)D6-A, HJ(X)D6-A, HHJXD6-A, CJD6, SJD6-A, SHJD6-A, SCJD6, L(X)D6-A, HL(X)D6-A, CLD6, SLD6-A, SHLD6-A, SCLD6	200-600	2, 3	1	500 Kcmil
Kits (contains lug and hardware for complete line of load end of 2 or 3 pole breaker)				
M(X)D6, HM(X)D6, CMD6, SMD6, SHMD6, SCMD6	500-800	2, 3	6, 9	500 Kcmil
N(X)D6, HN(X)D6, CND6, SND6, SHND6, SCND6	900-1200	2, 3	8, 12	500 Kcmil

Table Misc. 3 – Breaker Mechanical Lugs

For Use With Type(s)	Amp Rating	Cables Per Lug	Lug Wire Range
Load Side			
BQ, BQH, BQHF, BQE	15-20	1	#14-#10 AWG Cu
		1	#12-#10 AWG Al
BQF, BL, BLH	25-35	1	#8-#6 AWG Cu
		1	#8-#6 AWG Al
HBL, HBQ	40-50	1	#8-#6 AWG Cu
		1	#8-#4 AWG Al
Switching Neutrals	55-70	1	#8-#4 AWG Cu
		1	#8-#2 AWG Al
BG	80-100	1	#4-#1/0 AWG Cu
BLG	110-125	1	#2-#1/0 AWG Al
		1	#1/0-#2/0 AWG Al
BQD	15-40	1	#14-#6 AWG Cu
BQD6	45-100	1	#12-#6 AWG Al
		1	#8-1 AWG Cu
		1	#6-#1/0 AWG Al

Miscellaneous

Table Misc. 4 – Aluminum Body Lugs for Copper or Aluminum Wire

For Use With Type	Circuit Breaker Amp Rating	Cables Per Lug	Lug Wire Range
QJ2, QJH2	60-225	1	#6 AWG-300 kcmil (Cu)
QJ2H, HQJ2H			#4 AWG-300 Kcmil (Al)
All 2&3 pole	15-25	1	#14-#10 AWG (Cu)
ED2, ED4, ED6,			#12-#10 AWG (Al)
ED6ETI	30-100	1	#10-#1/0AWG (Cu or Al)
HED4,	110-125	1	#3-3/0 (Cu)
HHED6		1	#1-2/0 (Al)
CED6, All 1 Pole,	30-60	1	#10-4 (Cu or Al)
ED, HED	70-100	1	#4-#1/0 (Cu or Al)
FXD6-A, FD6-A, HFD6,	70-250	1	#6 AWG-350 Kcmil (Cu)
CFD6, HHFD6			#4 AWG-350 Kcmil (Al)
SJD6(A), SHJD6(A),	65-200	1-2	#4 AWG-310 Kcmil (Cu or Al)
SCJD6			
JXD2(A), JXD6(A),			
JD6(A), SJD6(A),			
HJD6(A), HHJD6(A),	200-400	1-2	3/0-500 Kcmil (Cu)
HHJD6, SHJD6(A),			4/0-500 Kcmil (Al)
CJD6, SCJD6			
LXD6(A), LD6(A),			
SLD6(A), HLD6(A),			
HHLXD6, HHLD6,	250-600	1-2	3/0-500 Kcmil (Cu)
SHLD6(A), CLD6, SCLD6			4/0-500 Kcmil (Al)
LMD6, ¹ LMXD6, ¹			
HLMXD6, ¹ HLMXD6, ¹	500-600	1-2	250-500 Kcmil (Cu or Al)
MD6, MXD6, SMD6,			
HMD6, HMXD6, SHMD6,	700-800	1-3	1/0-500 Kcmil (Cu or Al)
CMD6, SCMD6			500-750 Kcmil (Cu or Al)
ND6, NXD6, SND6,			
HND6, HNXD6, SHND6,	800-1200	1-4	250-500 Kcmil (Cu or Al)
CND6, SCND6			

¹ Use TA2K500 or TA3K500 only.

Table Misc. 5 – Optional Mechanical Lugs

For Use With Type	Circuit Breaker Ampere Rating	Cables Per Lug	Lug Material	Lug Wire Range	Quantity per Catalog Number
QJ2, QJH2	60-225	1	Cu	#6 AWG-250 Kcmil (Cu)	1
QJ2H, HQJ2H					
ED, HED, 2&3 pole	2-3 pole 30-125	1	Cu	#10-#1/0 (Cu)	
HFD6, HHFD6	70-250	1	Cu	#6 AWG-350 Kcmil (Cu)	1
CFD6, F(X)D6-A					
J(X)D2(A), J(X)D6(A),		1		3/0-600 Kcmil (Cu)	1
HJD6(A), HHJD6,		1,2	Cu	3/0-500 Kcmil (Cu)	1
SHJD6(A), L(X)D6(A),	250-600	1	Al	500-750 Kcmil (Al)	1
HHLD6, SCD6,					
HLD6(A), SHLD6(A),		1		500-600 Kcmil (Cu)	1
CJD6, CLD6, SCJD6,					
SCLD6					
SMD6, M(X)D6,	500-600	1-2	Cu	#1 AWG-500 Kcmil (Cu)	1
HM(X)D6, HMD6,		1-3	Cu	#1 AWG-350 Kcmil (Cu)	1
CMD6, SCMD6, SND6,	700-800	1-2	Al	500-750 Kcmil (Cu)	2
N(X)D6, HN(X)D6,		1-2	Al	500-750 Kcmil (Al)	3
SHND6, CND6, SCND6	800-1200	1-3	Al	500-750 Kcmil (Cu)	2
				500-750 kcmil (Al)	3

Miscellaneous

Table Misc. 6 – Miscellaneous Replacement Accessories

Catalog Number	Description	For Panel Type
EGK	Al Ground Assembly 44 Connections	P1, P2, P3
BK1	Bonding Kit for P1 250A Max.	as noted
BK4	Bonding Kit for SE & P5 400	as noted
IMK	Interior Adjusting Kit	P1, P2, P3
11-1824-01	Directory Card Holder	P1, P2, P3
12-1110-01	Directory Card	P1, P2, P3
11-1056-01	NEMA Instruction Book	All
NBK3	Number Strips 1-42	P1, P2, P3
NBK4	Number Strips 43-84	P1, P2, P3
NBK5	Number Strips 85-126	P1, P2, P3
NBK6	Number Strips 127-168	P1, P2, P3
ECGK	Cu Ground Bus 44 Connections	P1, P2, P3
IGK	Insulated Al Ground Bus	P1, P2, P3
ICGK	Insulated Cu Ground Bus	P1, P2, P3
EWK1	End Wall Kit with Knockouts (20"W x 5.75" DP)	P1
QF3 ¹	Filler Plate	P1, P2, P3, P4, P5

¹ All 1" QP, BL, BQD and ED Frame Provisions.

Connecting Strap Kits - Obsolete Circuit Breakers

For use with Series 5 or 6 CDP circuit breaker panelboards

Table Misc. 7

Breaker Frame ¹	Strap Kit Catalog Number	Height (in.)
KM, HN	6KM1	10
CN	6CN1	10
KMB, HNB	6KMB1	10
SKM	6SKM1	10
KP, HK	6KP1	10
KPB, HKB	6KPB1	10
SKP, SHK	6SKP1	10

Table Misc. 9 – Connecting Strap Kits — Vacu-Break

For use with VB-23 and VB-32 Type Panelboards.

Panel Type	Catalog Number	For Use With	
		Ampere Rating	Unit Height (in.)
VB-23	V2AX25	30-30	2 1/2
	V2BX50	30-30 and 60-60	5
	V7AX25	30-30	2 1/2
	V7BX50	30-30 and 60-60	5
VB-32	V7EX75	100-100	7 1/2
		100	7 1/2
		200	7 1/2 (2-Pole)
	V7FX100	200	10 (3-Pole)

FC20, FCI and FCII switchboards – includes copper straps, cover plates and necessary hardware.

Table Misc. 8 – Blank Plates – Vacu-Break

For use with VB-23, VB-30, VB-32 and Uni-Power Switchboards

Unit Height Inches	12 in. Units - 23 in. Wide Enclosure Only	17 in. Units - 30 in. and 32 in. Wide Enclosures
	Catalog Number	Catalog Number
2 1/2	VB2F025	VB7F025
5	VB2F050	VB7F050
7 1/2	VB2F075	VB7F075
10	VB2F100	VB7F100

Table Misc. 10 – Molded Case Switches (Non-Automatic Circuit Interrupters)

Ampere Rating	Breaker Frame
100	ED2, ED4, ED6
225	QJ2
250	FXD6
400	JXD2, JXD6
600	LXD6
800	MD6
1200	ND6

Siemens Industry, Inc.
5400 Triangle Parkway
Norcross, GA 30092

1-800-241-4453
info.us@siemens.com

usa.siemens.com/panelboards

Subject to change without prior notice.
Order No: PBCS-20301-0813
All rights reserved.
Printed in USA
©2013 Siemens Industry, Inc.

The information provided in this brochure contains merely general descriptions or characteristics of performance which in case of actual use do not always apply as described or which may change as a result of further development of the products. An obligation to provide the respective characteristics shall only exist if expressly agreed in the terms of contract.

All product designations may be trademarks or product names of Siemens AG or supplier companies whose use by third parties for their own purposes could violate the rights of the owners.