

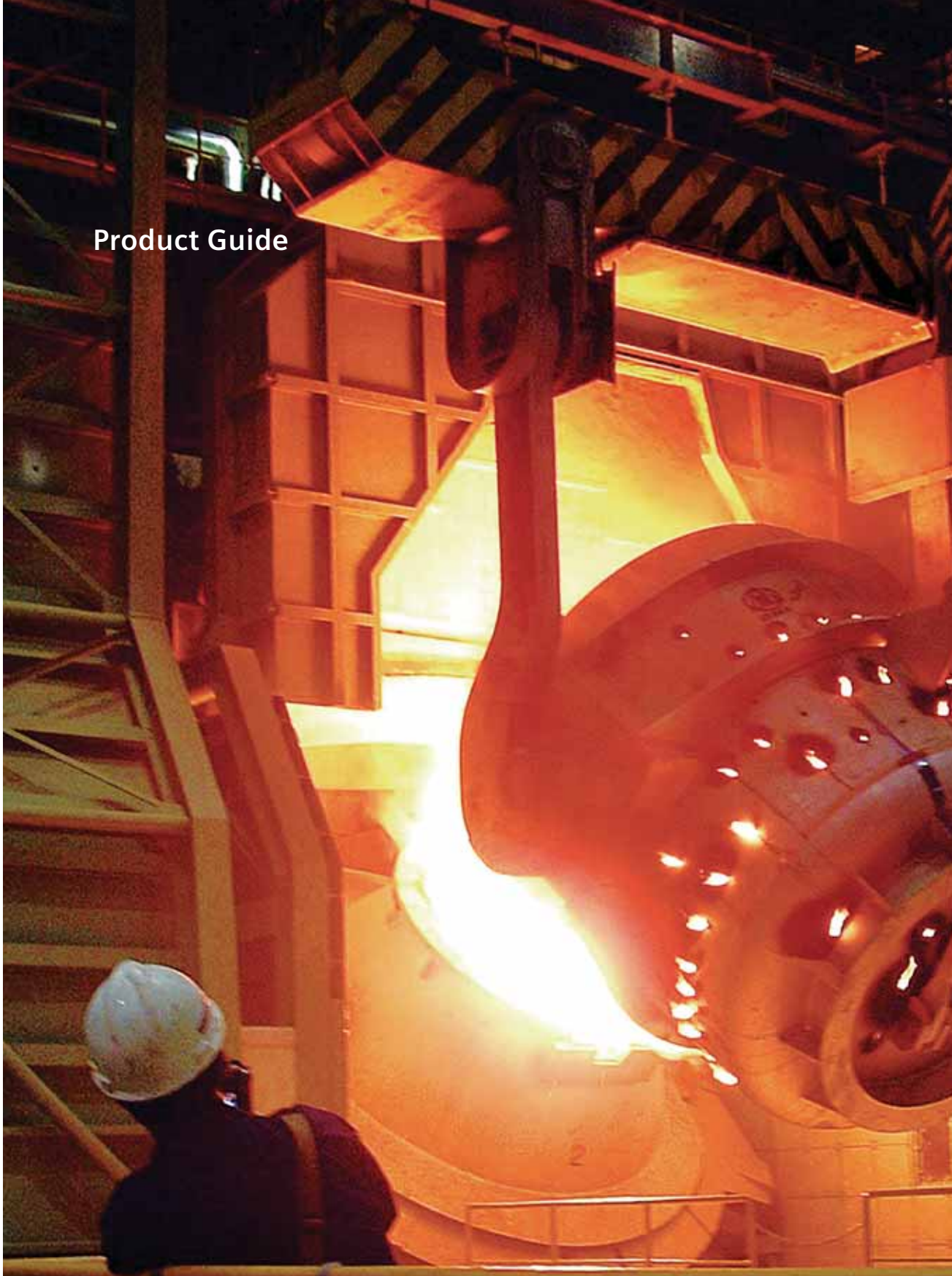

Product Guide



Low voltage grounding system

Answers for industry.

SIEMENS

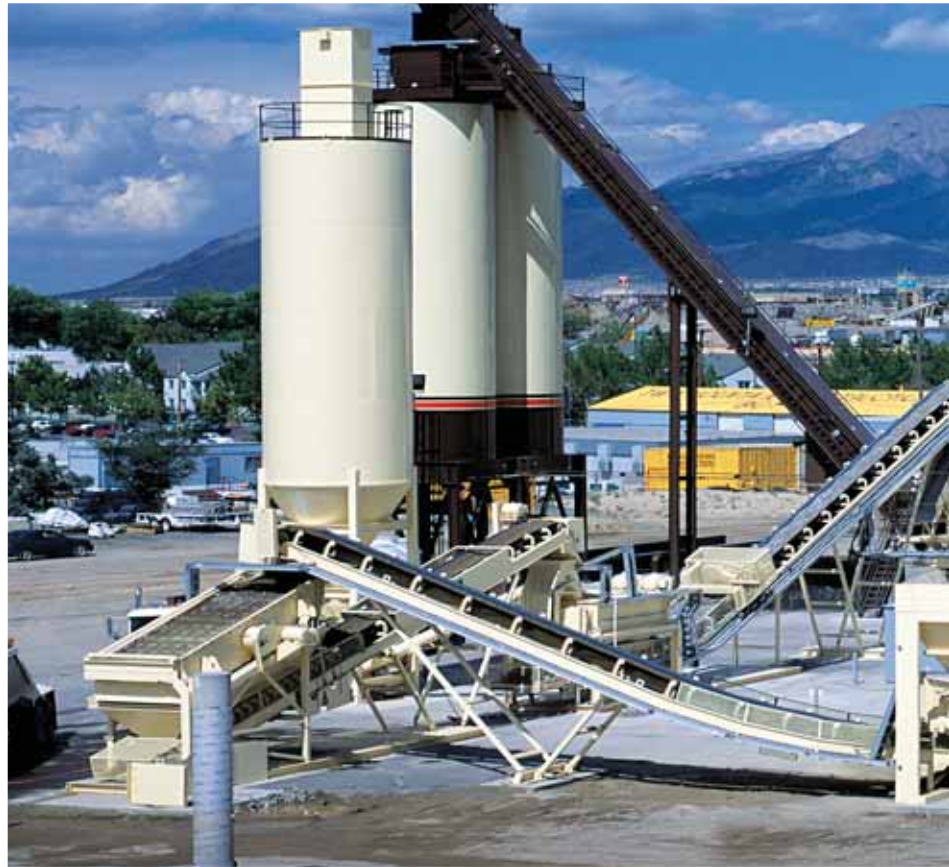

Advanced switchgear solutions for process industries

In today's high-tech manufacturing world, profitability can be greatly impacted by equipment shutdowns due to electrical faults. Industrial manufacturers demand solutions that minimize equipment downtime and optimize product efficiency.

Research shows that power failures cost U.S. industry more than \$25 billion a year in downtime. Recognizing the need for reliable and cost-efficient solutions, Siemens Energy & Automation provides state-of-the-art switchgear to eliminate downtime concerns in process industries and those where back-up power supply is critical.



Siemens low-voltage neutral grounding systems perform the following functions:

- Provides a high resistance ground connection for a 480-volt three-phase power system. This provides the continuity of service associated with ungrounded systems, while reducing the high transient over-voltages associated with them.
- Provides an immediate indication of the first system ground.
- Allows the system to operate until the fault is located and corrected.
- Provides a method for locating the fault quickly, before a second fault occurs. It should be noted that high resistance grounding systems cannot serve phase to neutral loads.

High resistance grounding system

Siemens offers high resistance grounding equipment specifically designed for use in industrial environments where continuous processes are used and equipment shutdowns are not an option. In these applications, the user prefers to maintain service during ground alarm indications that will lead to quick location and correction of the fault or a planned and orderly shutdown of the process.

Siemens low-voltage neutral grounding systems with pulsing ground fault detection circuitry are provided in two variations: a free-standing unit or one included in the Siemens 480V metal enclosed low-voltage power circuit breaker switchgear.

480V or 600V Delta Systems

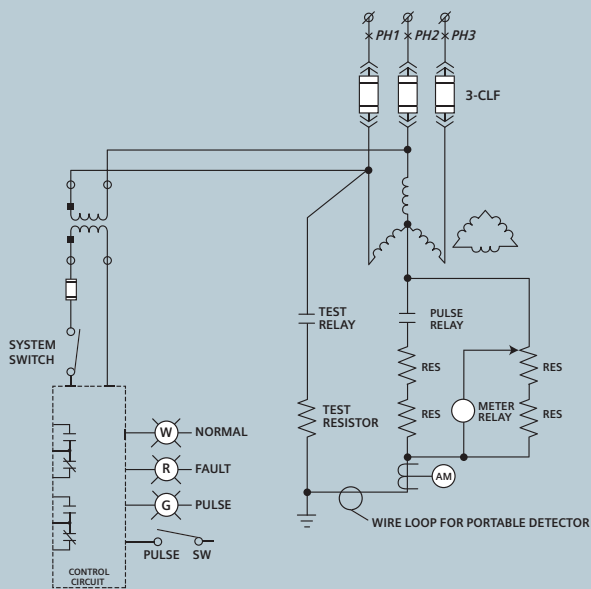

480V or 600V Wye Systems

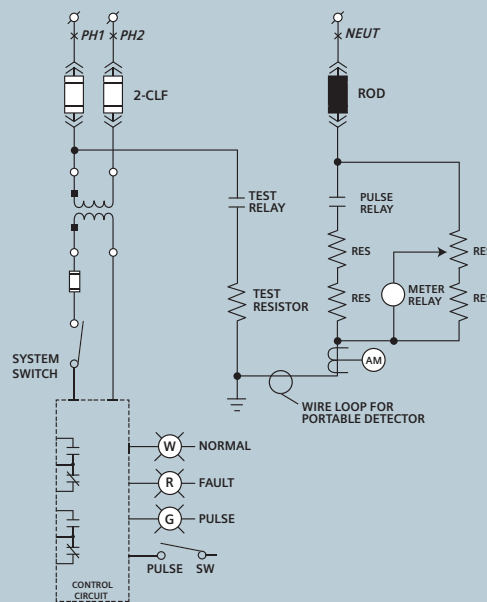

General description

During normal conditions, with no ground fault on the system, no voltage appears across the grounding resistors. A white indicating light on the panel indicates that control voltage is available and that the system is turned on.

When a ground fault occurs, the resistors limit the ground current to a low value, adjustable between 0.92 and 3.69 amperes. The voltage coil of the meter relay will sense the voltage across the resistors during a ground fault condition. In order to limit the voltage present on the instrument door, it is sensed across half of the resistance.

When a ground fault occurs, an auxiliary relay, operated by the meter relay, has contacts that illuminate a red indicating lamp and may be used for remote indication

and annunciation. The red light and remote signal remain until the condition is cleared and the system is reset.

To trace the ground fault, the operator turns the pulse switch on. This initiates the cycle timer alternately energizing and de-energizing a contactor that parallels a second resistor with the grounding resistor. The result is a periodic fluctuation in the magnitude of the ground current, doubling its value. A green indicating lamp follows the pulse.

A clamp-on ammeter is then used to first see the signature of the pulse at the loop in the resistor grounding wire, and then trace the fluctuations in ground current through the system to the point of fault. The signature current fluctuation observed on a portable clamp-on ammeter stops

once the ground fault is between the ammeter and the neutral resistor. A current transformer and panel-mounted ammeter will allow the operator to determine the current fluctuations on the system.

After the ground point has been located and removed from the system, the operator turns the pulse switch off, de-energizing the pulse cycle timer circuit, and depresses the reset button to reset the fault indicating light and alarm contacts.

Taps are provided on the resistors to adjust the magnitude of the ground current in the range of 0.92 to 3.69A, depending on the size of the system, so that the current through the resistor to a ground fault will be slightly greater than the system's natural capacitance charging current. Both the grounding resistor and pulsing resistor should be set to the same value.





Standard Equipment List

Equipment included in Standard 480V or 600V WYE System with System Neutral available (one of each)

- Meter relay (MR)
- "Normal" white indicating light (W)
- "Ground Fault" red indicating light (R)
- "Pulsing" green pulsing indicated light (G)
- "Reset" push button (PB/RESET)
- "Test" push button (PB/TEST)
- On – Off switch (System Switch)
- On – Off switch (Pulse Switch)
- Instruction plate on door
- Repeat cycle timer, set to produce approx. 30 current pulses per minute (RCT)
- Neutral grounding resistor assembly (HRED, HREE)

- Pulse resistor assembly (HREB, HREC)
- Test resistor assembly (HREA)
- Relay for repeat cycle timer (PR)
- Alarm relay, with extra interlocks for remote alarm (59X)
- Control Power Transformer (CPT)¹
- Portable clamp on ammeter (optional)
- Neutral current transformer (CT)
- Neutral ammeter (AM)

Equipment included in Standard 480V or 600V Delta System without System Neutral available.

Same as WYE system with the addition of

- Three grounding transformers for generating a neutral (CPT)

¹ When included in a switchgear line up, the control power is common with the switchgear.

Typical Dimensions

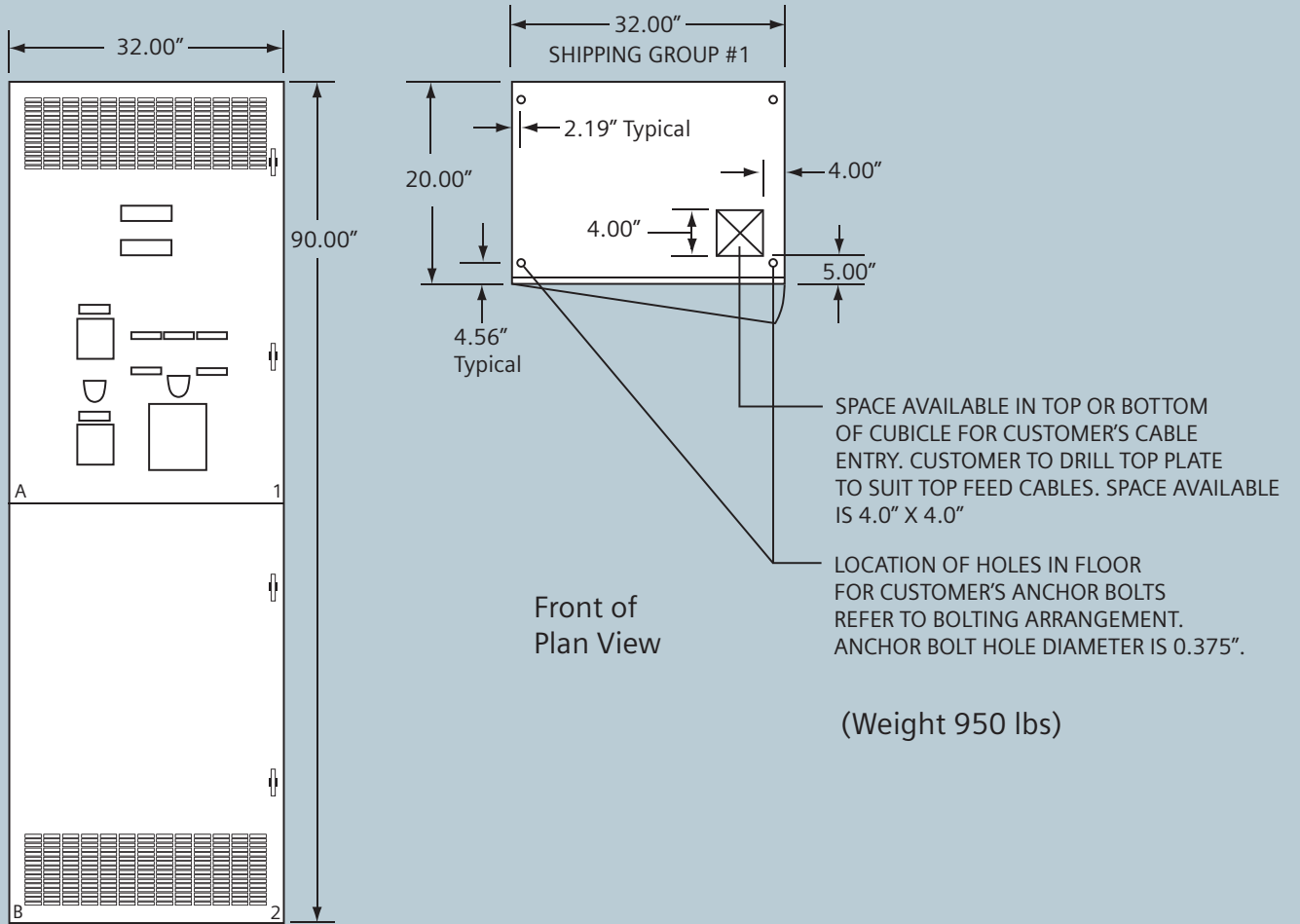

(Weight 950 lbs)

Front View

Siemens Energy & Automation, Inc.
Industry Sector
3333 Old Milton Parkway
Alpharetta, GA 30005
1-800-964-4114

Subject to change without prior notice
Order No.: LVTA-GRDS1-0709
Printed in USA
© 2009 Siemens Energy & Automation, Inc.

info.sea@siemens.com

www.sea.siemens.com/switchgear

The information provided in this brochure contains merely general descriptions or characteristics of performance which in case of actual use do not always apply as described or which may change as a result of further development of the products. An obligation to provide the respective characteristics shall only exist if expressly agreed in the terms of contract.

All product designations may be trademarks or product names of Siemens AG or supplier companies whose use by third parties for their own purposes could violate the rights of the owners.