

Siemens Energy & Automation, Inc.
Bellefontaine, Ohio 43311 U.S.A.

For questions call 1-800-241-4453 or our web site:
<http://www.sea.siemens.com/dpd>

Installation Instructions



⚠ DANGER
Hazardous voltage.
Will cause death or serious injury.

Turn off and lock out all power supplying this device before removing cover(s) or device and while cover(s) are removed.

Replace the covers and shields before power supplying this device is turned on.



SAFETY INSTRUCTIONS

Note: This instruction outlines recommended installation procedure.

The PMK trip units are available in 1400 and 1600 ampere ratings. These devices have adjustable magnetic trip settings. The 1400 and 1600 ampere trip units have a range from 5,000 to 10,000 amperes. See breaker frame label or consult Siemens Energy & Automation, Inc. sales office for complete catalog number information.

Mounting Procedure for Trip Unit

1. Remove terminal shield from load side of breaker frame. Two 8-32 screws.
2. Remove load cover from breaker frame. Six 10-32 X 3/4" screws and two 10-32 X 1-3/8" screws.
3. Lower trip unit into place as shown in Figure 2. The two hooks on the trip unit must fit over pins on frame. Handle may be removed to ease assembly.
4. Secure trip unit to frame. Tighten six 5/16-18 socket head cap screws to 140 in.-lbs.
5. Replace load cover. The six 10-32 X 3/4" screws must be installed toward the line side of the circuit breaker. The two 10-32 X 1-3/8" screws are installed on the load end. Tighten all load cover screws to 25 in.-lbs. Replace handle if removed: note tab on front of handle must be towards the line end.
6. Check operation of circuit breaker. Reset breaker by moving handle towards load side of device until it catches. Then move handle in opposite direction until the breaker turns on. The handle will indicate "ON", then depress the "Push-To-Trip" button. The breaker should trip, and the handle will move between the "ON" and "OFF" positions.

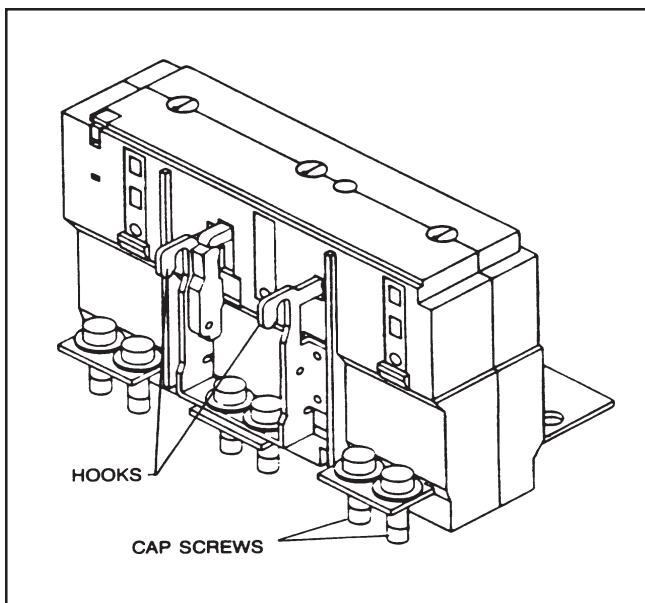
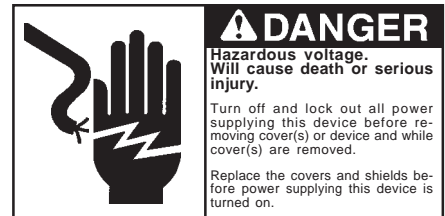

Fig. 1



Installation Instructions

NOTE: If the breaker does not operate as noted, check all installation procedures and repeat this step. If the load cover is not properly secured the breaker will not operate.

- Secure load end connection of breaker.
- Install end plate (supplied with frame) and replace terminal shield. Tighten two 8-32 screws until cover sits flush with the end of the breaker.
- Attach rating label, supplied with the trip unit, to the recessed area on the top of the handle.
NOTE: Make sure rating label agrees with ampere rating of trip unit installed.
- Move handle to reset position, handle will indicate "OFF". Circuit breaker is now ready for use.

Replacement Procedure for Trip Unit

NOTE: Circuit Breaker must be in "Tripped" position before removing cover. To trip the breaker depress the red "Push-To-Trip" button.

- Remove terminal shield from load side of breaker frame. Two 8-32 screws.
- Remove load cover from breaker frame. Six 10-32 X 3/4" screws and two 10-32 X 1-3/8" screws.
- Remove load side connection screws.
- Remove trip unit. Six 5/16-18 socket head cap screws.
NOTE: These screws will remain captive with trip unit.
- Add new trip unit as outlined in steps 3 thru 10 of "Mounting Procedure for Trip Unit".

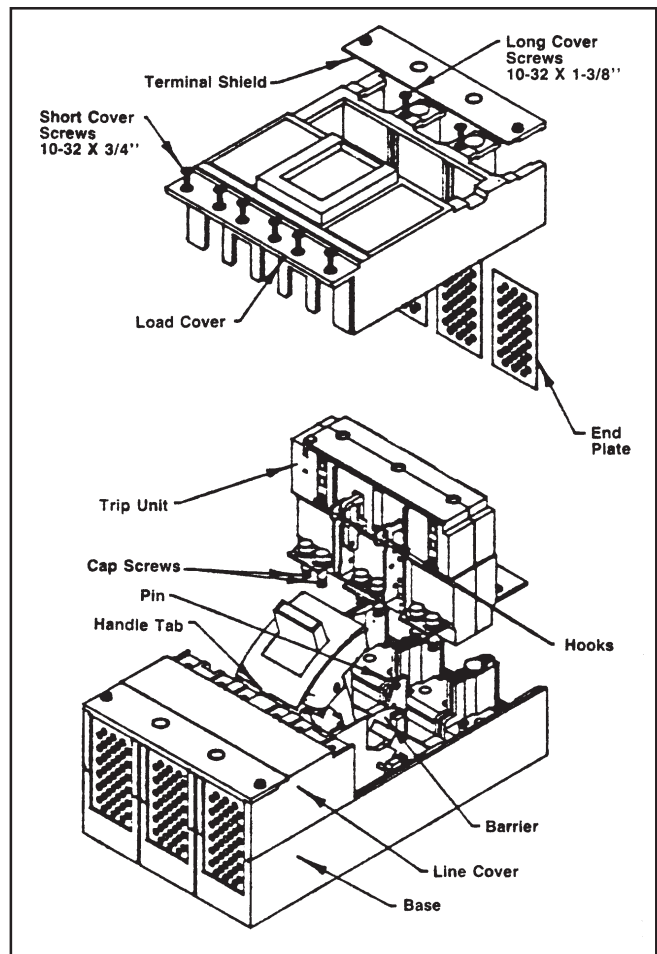

Fig. 2