



## Installation Instructions

	<b>⚠ DANGER</b>
	<p><b>Hazardous voltage.</b> Will cause death or serious injury.</p> <p>Turn off and lock out all power supplying this device before removing cover(s) or device and while cover(s) are removed. Wire connector shield no. NDTs must be installed when wire connectors 3TA2K8750, 3TA4P8500, 3TA2N8750, 3TA3N8750 or 3TA4N8500 are used.</p> <p>Replace all covers and shields before power supplying this device is turned on.</p>



### SAFETY INSTRUCTIONS

NOTE: This instruction outlines the recommended installation procedure.

### INTRODUCTION

The MM and NM Circuit Breaker lines include types MM6, MMK, NM6 and NMK, available with Instantaneous Magnetic Trip Units and Thermal Magnetic Trip Units. The MMKT trip units are interchangeable and can be used with circuit breaker types MM6 and MMK, according to its application. The NMKT trip units are interchangeable and can be used with circuit breaker types NM6 and NMK, according to its application. Every trip unit has three dials, one for each pole, to adjust the magnetic pickup settings. The bimetal elements in the Thermal Magnetic Trip Units have been calibrated according to the rated continuous current and rated ambient temperature. Special calibrations and trip settings have been made to accommodate the MSHA Trailing Cable requirements.

The MM6 Instantaneous Magnetic Trip Circuit Breakers are rated for operating voltages up to 600VAC, 50/60Hz, 500VDC and continuous current of 800 amps.

The MM6 Thermal Magnetic Trip Circuit Breakers are rated for operating voltages up to 600VAC, 50/60Hz, 500VDC and continuous current from 500 to 800 amps.

The NM6 Instantaneous Magnetic Trip Circuit Breakers are rated for operating voltages up to 600VAC, 50/60Hz, 500VDC and continuous current of 1200 amps.

The NM6 Thermal Magnetic Trip Circuit Breakers are rated for operating voltages up to 600VAC, 50/60Hz, 500VDC and continuous current from 900 to 1200 amps.

The MMK Instantaneous Magnetic Trip Circuit Breakers are rated for operating voltages up to 1000VAC, 50/60Hz, 500VDC and continuous current of 800 amps.

The MMK Thermal Magnetic Trip Circuit Breakers are rated for operating voltages up to 1000VAC, 50/60Hz, 500VDC and continuous current from 500 to 800 amps.

The NMK Instantaneous Magnetic Trip Circuit Breakers are rated for operating voltages up to 1000VAC, 50/60Hz, 500VDC and continuous current of 1200 amps.

The NMK Thermal Magnetic Trip Circuit Breakers are rated for operating voltages up to 1000VAC, 50/60Hz, 500VDC and continuous current from 900 to 1200 amps.

### INSTALLATION

MM and NM Frame circuit breakers are for use in individual enclosures, panel boards, switchboards or other approved equipment.

The installation procedure consists of inspecting, attaching required accessories, mounting the device and connecting and torquing the line and load wire connectors.

Mounting hardware and unmounted wire connectors (where required) are available as separate catalog items.

NOTE: Trip unit and accessory installation should be completed before the circuit breaker is mounted and connected. (See installation instructions supplied with trip unit and accessory before proceeding).

NOTE: Do not spray or allow any petroleum based chemicals, solvents or paints to contact the molded parts or nameplates.

- A. Turn off and lock out all power before installing or servicing.
- B. WARNING! Make sure that the circuit breaker / trip unit is suitable for the installation by comparing nameplate ratings with system requirements. Inspect the device for completeness and check for any damage before mounting.
- C. The circuit breaker must be in the "Tripped" or "OFF" position prior to mounting.
- D. To mount the circuit breaker perform the following steps:
  1. For those applications where mounting is on a flat surface of the customers equipment, drill and tap mounting bolt holes according to the drilling plan in Fig. 2. For handle escutcheon cut out plans refer to Fig. 3.
  2. If the circuit breaker contains internal accessories, make sure terminals can be connected when the circuit breaker is mounted.
  3. Remove the line and load terminal shields (see Fig. 4) by loosening the two terminal shield screws that attach them to the line and load covers.



# Installation Instructions

4. Position the circuit breaker on mounting surface.
5. Install mounting screws and washers. Tighten hardware securely.
6. After mounting the circuit breaker, line and load terminals and accessory terminals should be connected. Install wire connectors with correct torque requirements. Torque values for line and load connectors are provided on the circuit breaker nameplate and in Table 1, Page 2 of 3. Ensure that wire and wire connectors are fully engaged on terminals and that connectors are flush with end of terminal.
7. Lug Shield Kit (Cat. No. NDTs) is **required** to be installed on the line and load ends, when the MMK and NMK Circuit Breakers are operated at 1000VAC. NDTs Lug Shields are also **required** to be installed when Pressure Wire Connectors 3TA2K8750, 3TA4P8500, 3TA2N8750, 3TA3N8750, 3TA4N8500 and Crimp Connectors CCM800K3 and CCN1200K3 are used. The NDTs Lug Shields are **recommended** to be installed on the line and load ends, when the MM6, NM6, MMK and NMK Circuit Breakers are operated at 600VAC. See NDTs Lug Shield instruction sheet.
8. After the device is installed, check all mounting hardware for secureness.
9. Replace line and load terminal shields and tighten screws securely.

**TABLE 1.**

Catalog Number	Wire Range	Torque	
		Cable Clamping Screw	Connector Mounting Screw
TA2K500 TC2K500 TC3K350 TA3K500 3TA2K8750 3TA2N8750 3TA3N8750 3TA4P8500 3TA4N8500 CCM800K3 CCN1200K3	#1-500 kcmil. Cu/Al #1-500 kcmil. Cu Only #1-350 kcmil. Cu Only 1/0-500 kcmil. Cu/Al 500-750 kcmil. Cu/Al 500-750 kcmil. Cu/Al 500-750 kcmil. Cu/Al 250-500 kcmil. Cu/Al 250-500 kcmil. Cu/Al (See Instructions) (See Instructions)	375 lb-in. [42.37 N-m]	96 lb-in. [10.84 N-m]
			228 lb-in. [25.76 N-m]

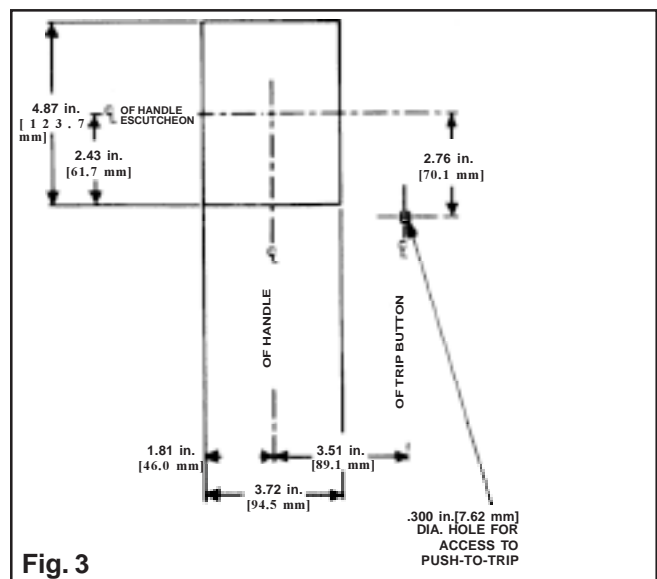
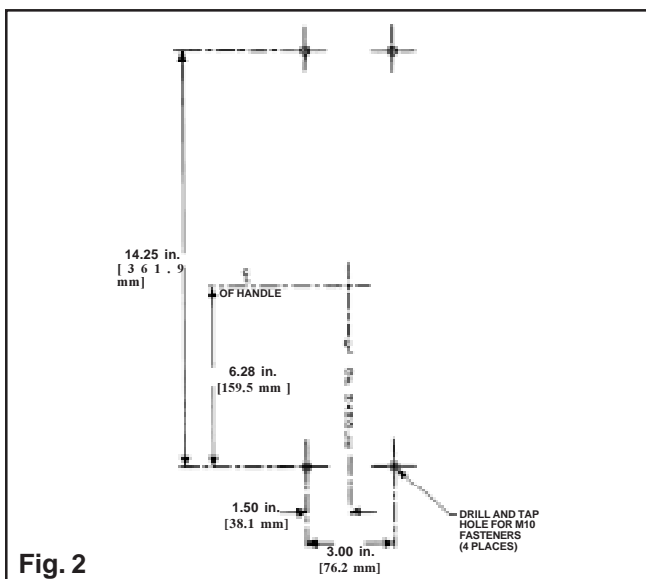

**Fig. 2**

**Fig. 3**



# Installation Instructions

## MANUAL OPERATION

Manual operation of the circuit breaker is controlled by the circuit breaker handle and the PUSH-TO-TRIP button. The handle has three indicating positions, two of which are molded into the handle to indicate ON and OFF. The third position indicates a TRIP position and is between the ON and OFF positions. (See Fig. 4)

### A. Circuit Breaker Reset

After tripping, the circuit breaker is reset by moving the circuit breaker handle to the reset position and then moving the handle to the ON position.

NOTE: In the event of a thermal trip, the circuit breaker cannot be reset until the thermal element cools.

### B. PUSH-TO-TRIP Button

The PUSH-TO-TRIP button checks the tripping function and is used to manually exercise the operating mechanism.

## INSPECTION AND FIELD TESTING

MM and NM Frame Circuit Breakers are designed to provide maintenance free service. Any inspection and field testing should be conducted in accordance with NEMA AB2: Procedures for Field Inspection and Performance Verification of Molded Case Circuit Breakers ; also NEMA AB4 : Guidelines for Inspection and Preventive Maintenance of Molded Case Circuit Breakers.

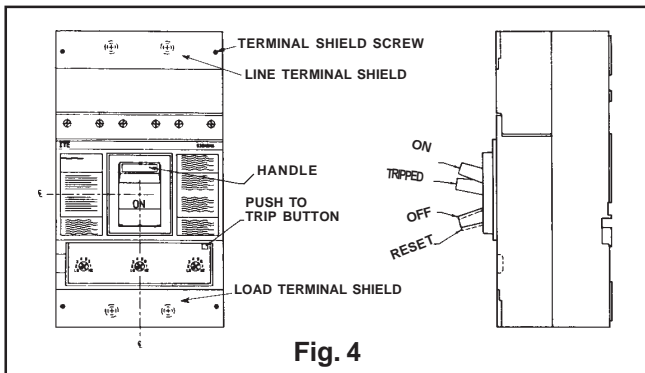

Manufactured Under One or More of the Following U.S. Patents: 4,260,861; 4,266,209; 4,300,030; 4,458,224.