

Installation Instructions



⚠ DANGER

Hazardous voltage. Will cause death or serious injury.

Turn off and lock out all power supplying device before removing cover(s) or device and while cover(s) are removed.

Replace all covers and shields before power supplying this device is turned on.

⚠ SAFETY INSTRUCTIONS

NOTE: This instruction outlines the recommended installation procedure.

To install catalog #PRDBS1 on PD breakers, motor circuit interrupters and molded case switches.

1. Make sure all power supplying this device is de-energized / turn off.
2. Remove #8-32 screws that secure terminal cover(s) from circuit breaker.
3. Place (1) connector strap Item 4 onto top surface of terminal.

4. Secure Item 4 with (2) Item 1 M8 x 50mm screws and (2) Item 2 spring washers. Place (1) Item 3 nut plate into (1) Item 8 rear terminal barrier. Then place Item 3 & Item 8 on bottom surface pocket of terminal. Push in until seated. Torque Item 1 to 24 N-m (212 in-lb).
5. Repeat steps 3 & 4 until all terminals (line side and load side) are completed.
6. Connect Item 4 to customer busway (customer supplied mounting hardware). Make sure that ground to phase clearance is minimum ½" through air and 1" over surface for 600 volt systems.
7. Place (1) Item 6 terminal shield into slot of cover. Push downward until Item 6 is seated.
8. Replace terminal cover on circuit breaker. The two tabs on Item 6 should fit into the notches in the terminal cover. Tighten (2) #8-32 screws 20-22 in.lbs. Item 6 should be held securely when properly installed.
9. Circuit breaker is now ready to use.

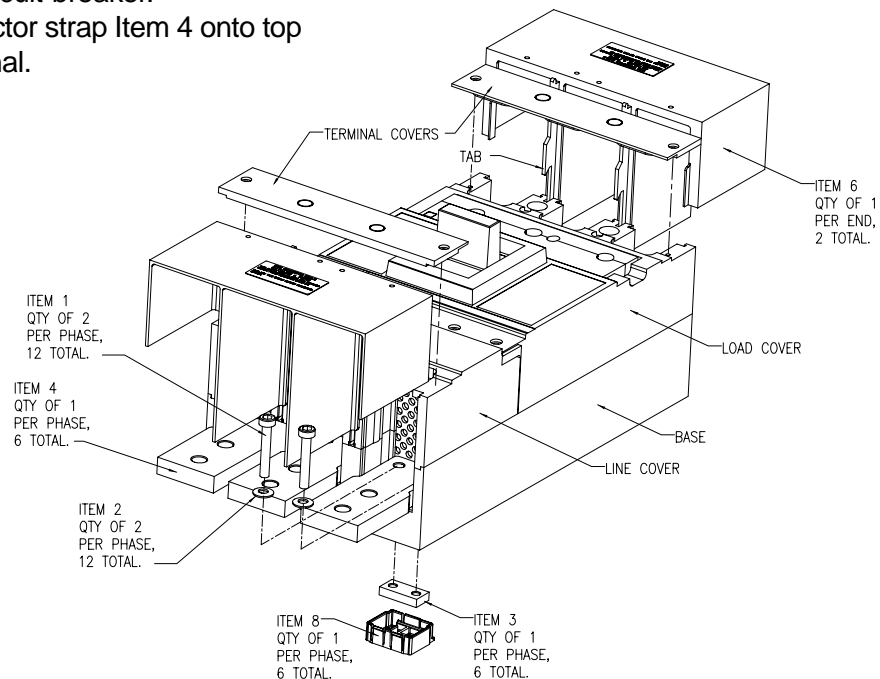

Figure 1