

## Installation Instructions

	<b>⚠ DANGER</b>
	<p><b>Hazardous voltage.</b> <b>Will cause death or severe injury.</b></p> <p>Turn off and lock out all power supplying circuit breaker or frame before removing cover(s) or device and while cover(s) are removed.</p> <p>Replace all covers and shields before power supplying this device is turned on.</p>



### SAFETY INSTRUCTIONS

**NOTE:** This instruction outlines the recommended installation procedure.

1. Turn power off supplying device before installing kit.
2. Prepare mounting panel as shown in Fig. 1 or Fig. 2.
3. Break out proper knock-out in circuit breaker base (see Fig. 3) using screwdriver. Use needle file to smooth opening in base to indicated dimensions in both cases. Prevent loose plastic from entering base. Test to see that plunger Fig. 4, item 8 moves freely within opening.
4. Assemble support item 1, and spacers item 2, to rear of panel using screws item 3, lockwashers item 4, and nuts item 5 supplied as shown in Fig. 4. Torque to 32 In.-Lbs.[3.62 N/m].

**NOTE:** Spacers, each .015 in.[0.38] thick, are provided. Use quantity of spacers indicated on chart in upper right hand corner. Example: If

customer panel is 12 Ga. use four (4) spacers.

**CAUTION:** Malfunction of the mechanical interlock could occur if the dimensions shown in Figs. 1, 2 and 4 are not maintained. This could result in property damage.

**Mount the circuit breakers and the interlock support on one single rigid panel,** carefully observing the dimensions shown in Fig. 1, 2 and 4 to insure that all interface dimensions remain fixed during the service life of the interlock and breakers. Make certain that long unsupported mounting panel surfaces are provided with bracing to prevent flexure.

5a. Attach the rocker arm, item 6, to the support, item 1. Washers item 11 must be located inside the support, with one on each side of the rocker arm. Secure the rocker arm pin, item 7, with the cotter pin, item 9.

b. Place one centering spring, item 10 between the panel rear surface and one end of the rocker arm. Center the spring over the applicable holes and insert the plunger, item 8 through the rocker arm and spring, being certain that the plunger is oriented as shown in Fig. 4.

c. Insert a rocker arm pin through the rocker arm and the plunger hole closest to the circuit breaker for panel mounted breakers. Use the hole most distant from the breaker for plug-in mounted breakers. Secure the pin with a cotter pin.

d. Compress the installed spring by rotating the rocker arm. Complete the assembly required for the second circuit breaker by repeating steps b and c.

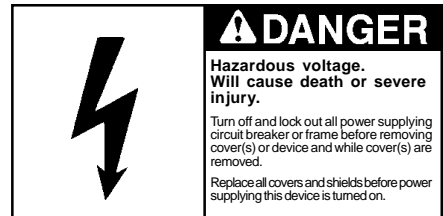

# Installation Instructions

## INTERLOCK CHECKOUT AND AJUSTMENT.

**NOTE:** The mechanical interlock plungers, Fig. 4, Item 8, are actuated by cam surfaces located in the circuit breakers. Mounting panel thickness variations, surface irregularities and system tolerances may require the addition or removal of spacers, Fig. 4, item 2, to adjust interface dimensions. Step 6 will determine if there is a requirement to add spacers. Step 7 will show if spacers should be removed.

6a. Check “ON-OFF” function of each circuit breaker. If the “ON-OFF” operation is normal, proceed with Step 7.

b. If either circuit breaker cannot be turned “ON”, loosen the support screws Item 3, and install one additional spacer, Item 2. Retorque the screws (32 In.-Lbs.[3.62 N/m]). Repeat Step 6a. A second additional spacer can be installed if required.

7. The interlock will prevent closing of one or both of the circuit breakers, if they are simultaneously driven to the “ON” position. Check this function by manually synchronizing turn “ON” of both circuit breaker toggle handles.

a. If neither breaker closes, or only one breaker closes, proceed with Step 8.

b. If both breakers “CLOSE”, loosen the support screws, Fig. 4, Item 3, and remove one of the spacers, Item 2. Retorque the screws to (32 In.-Lb.[3.62 N/m]). Repeat Step 7a. A second spacer can be removed, if required.

**NOTE:** Avoid unnecessary simultaneous “TURN ON” operations, since they cause high mechanical loading on circuit breaker and interlock components.

- 8. Recheck each circuit breaker for normal “ON-OFF” operation.
- 9. Turn each circuit breaker “ON”. Confirm that the other circuit breaker cannot be closed.
- 10. **LABEL:** Mechanical Interlock - Peel off protective backing from adhesive labels, (2), and attach labels to front of each circuit breaker as shown below.

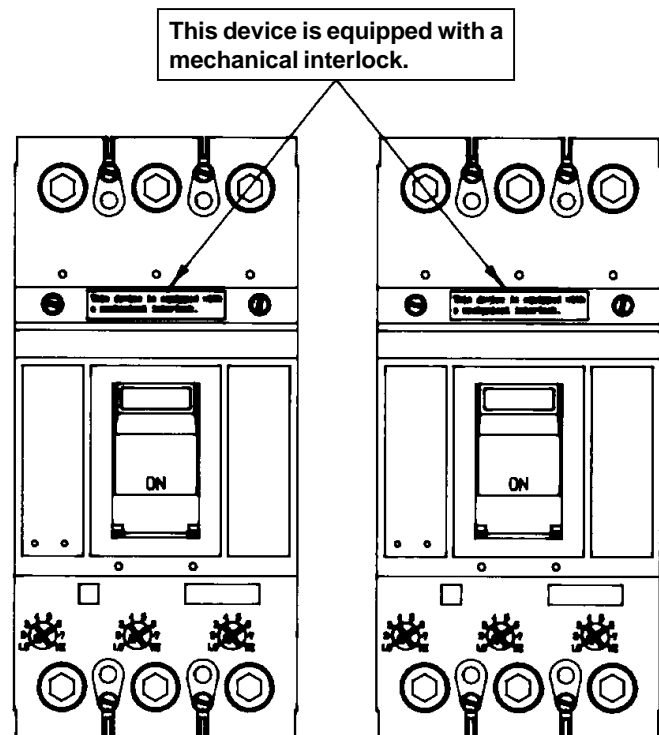

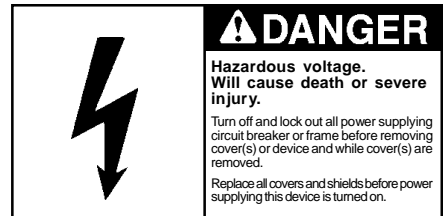

# Installation Instructions

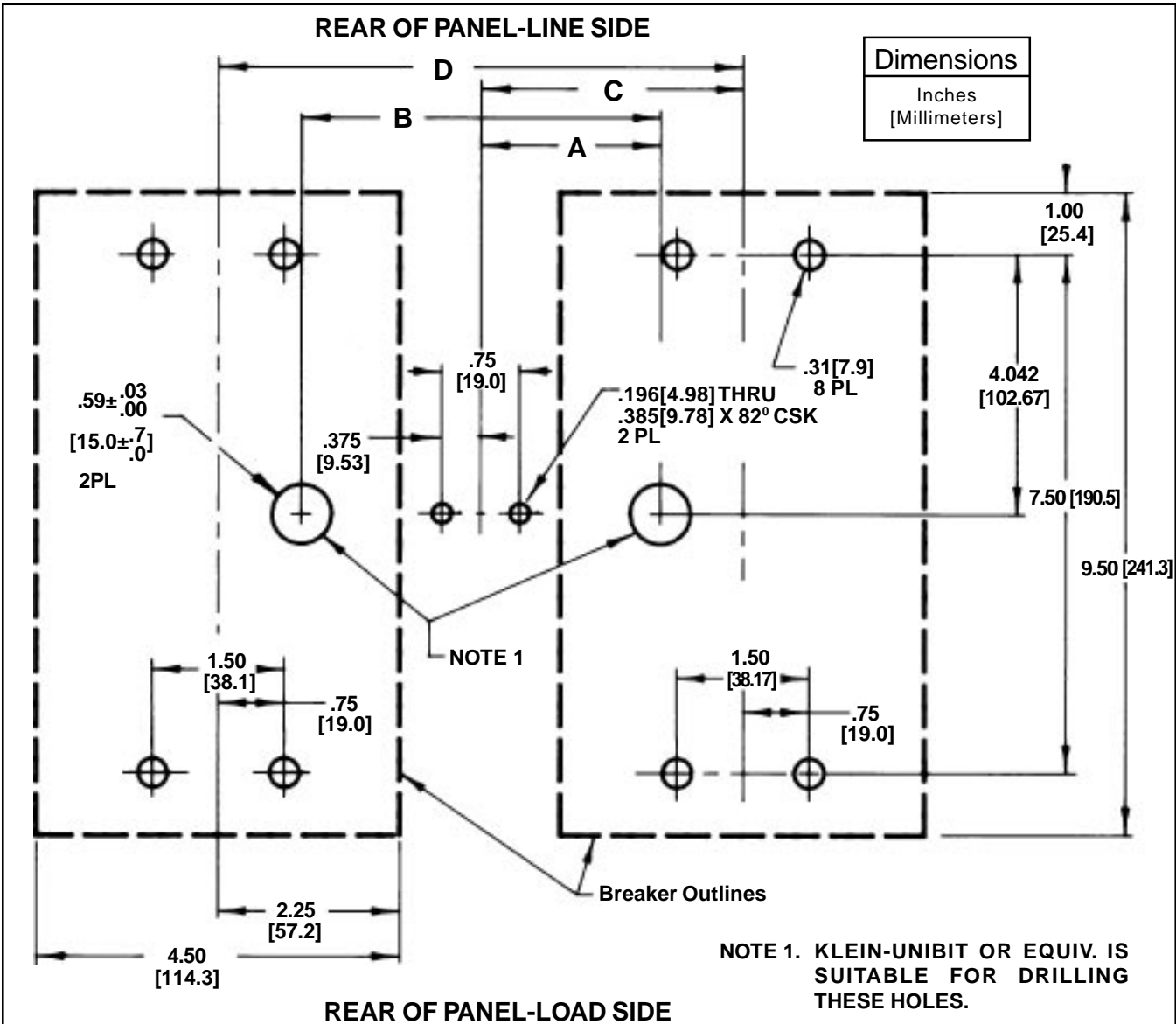

BREAKERS ON	A	B	C	D
4.50 IN.[114.3] CENTERS	1.273 [32.33]	2.546 [64.67]	2.25 [57.2]	4.50 [114.3]
6.00 IN.[152.4] CENTERS	2.023 [51.38]	4.046 [102.77]	3.00 [76.2]	6.00 [152.4]

**Fig. 1 HOLE PATTERN FOR PANEL MOUNTED CIRCUIT BREAKERS**



# Installation Instructions

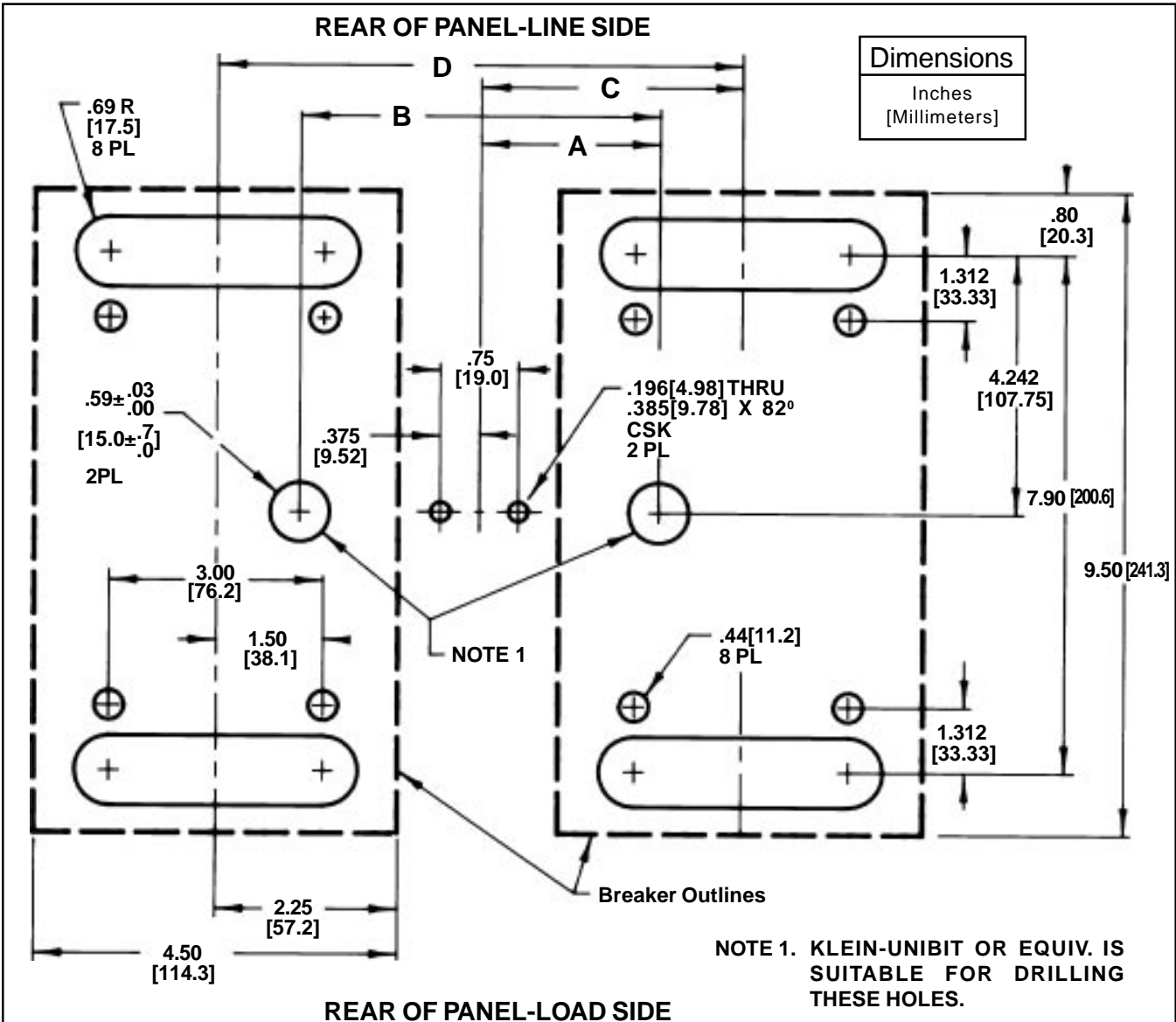

BREAKERS ON	A	B	C	D
4.50 IN.[114.3] CENTERS	1.273 [32.33]	2.546 [64.67]	2.25 [57.2]	4.50 [114.3]
6.00 IN.[152.4] CENTERS	2.023 [51.38]	4.046 [102.77]	3.00 [76.2]	6.00 [152.4]

**Fig. 2 HOLE PATTERN FOR PANEL MOUNTED CIRCUIT BREAKERS**

**⚠ DANGER**

**Hazardous voltage.**  
 Will cause death or severe injury.

Turn off and lock out all power supplying circuit breaker or frame before removing cover(s) or device and while cover(s) are removed.

Replace all covers and shields before power supplying this device is turned on.

# Installation Instructions

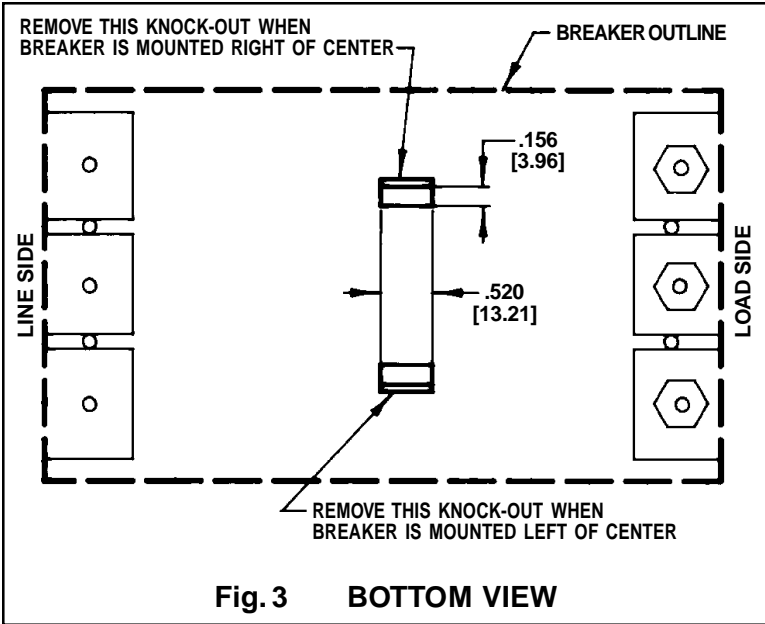

### Dimensions

Inches  
[Millimeters]

Ga. NO.	Nominal THK In.	QTY of spacers
<b>10</b>	<b>0.135</b> [3.43]	<b>2</b>
<b>11</b>	<b>0.12</b> [3.0]	<b>3</b>
<b>12</b>	<b>0.105</b> [2.67]	<b>4</b>
<b>13</b>	<b>0.09</b> [2.3]	<b>5</b>
<b>14</b>	<b>0.075</b> [1.90]	<b>6</b>
<b>16</b>	<b>0.06</b> [1.5]	<b>7</b>

