

# SIEMENS

## Indoor/Outdoor Service Entrance Module

Catalog Number

- WB31400B**  
 **WB31400BU**

Enclosure

**Type 3R**

### Module Rating:

1400 Amps Max; See main breaker for actual rating.  
 Main Bus Rating: 1200 Amps Max (1200 Amps Max feed per side)  
 208Y/120 Volts~, 3 Phase, 4 Wire  
 240/120 Volts~, 3 Phase, 4 Wire, Delta (B Phase is High Leg)  
 240 Volts~, 3 Phase, 3 Wire

For installation by Qualified Person in accordance with all local electrical codes and/or the National Electrical Code®.

### Suitable Only For Use As Service Equipment.

For underground service only.

### Use 75°C Copper or Aluminum Conductors.

Terminals A, B, C and N:

See Lug Chart on adjacent diagram for applicable lug kits, wire size and torque information.

Ground terminal G:  
 Wire size #4-300 kcmil.  
 Torque terminal to 250 lb.-in.

Circuit breaker trip position is indicated by handle position midway between ON and OFF. To reset, move handle to OFF position, then turn ON.

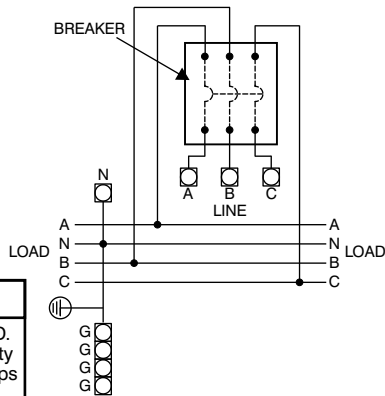

### CAUTION

**HAZARD OF ELECTRICAL OVERLOAD.** Can result in personal injury or property damage. Mains that exceed 1200 Amps must be installed in the middle of the panelboard lineup with a maximum of 1200 amps exiting either side of the main device.

See adjacent labels for additional marking information.

49311229

Siemens Industry, Inc. Norcross, Georgia U.S.A.

**D**

40900057 0101 Rev.B

© The National Electrical Code is a registered trademark of the National Fire Protection Association.  
 © 2009 Copyright Siemens Industry, Inc.

# SIEMENS

**Connect Modules Using:**

**Cat. No.**

**Torque**

Single Bolt Joint                      SBJ4                      400-480 lb-in (35-40 ft.-lb.)  
 Quick Connect™                      QC4                      400-440 lb-in (35-36 ft.-lb.)

### Lugs for Phase and Neutral Connections (not supplied)

Lug No.	①	MFG	Wire Range	Type	No. Wires per phase	Torque (lb.-in.)
LK35600N2		Siemens	1/0-600 kcmil	Mechanical	1	375 ②
					4	500 ②
LK35750N2		Siemens	300-750 kcmil	Mechanical	1	500 ②
					4	500 ②
2ACL-600		ILSCO	500 kcmil	Compression	5	NA ③
2ACL-750		ILSCO	750 kcmil	Compression	5	NA ③

- ① Order one mechanical lug kit for main breaker and neutral conversions. Contact lug manufacturer for compression lug quantities supplied for each kit.
- ② Kit contains more than one lug type. Reference kit instruction sheet for the actual torque value for each lug type.
- ③ See lug manufacturer's instruction sheet supplied with the connector for tool, die, and number of crimps.

### IMPORTANT - for use with:

Module	Siemens Series#	Murray Series#
Main Breakers . . . . .	(W)MC, WB, WEB . . . . .	DB W
Switches . . . . .	WMP, WMS, WS, WES . . . . .	DPT_W, DT_W
Tap/Terminal Boxes . . . . .	WMTB, WTB, WET . . . . .	DTB_W
Meter Module . . . . .	WMM, WxMM, WMT, WML, WMK . . . . .	DG_W, DC_W, DL_W
Extension Box . . . . .	WMEX, WSP . . . . .	DS
Bussed Elbow . . . . .	(W)BE . . . . .	DL

### Short Circuit Current Rating

This device has a maximum short circuit current rating of 100,000 amps RMS symmetrical at 240 Volts ~. The actual short circuit current rating is limited to the interrupting rating of the circuit breaker installed. Replacement breakers must be manufactured by Siemens and must be of the correct type and rating as indicated in the table below. Use of other circuit breakers in this device will void the warranty.

Breaker Type	Rating
PXD6	65k AIC
HPXD6	100k AIC

USE ONLY NON-INTERCHANGEABLE TRIP BREAKER TYPES

**Important:** Do not allow petroleum based (hydrocarbon) sprays, chemicals, solvents or any paint to contact interior components. Petroleum based chemicals can cause degradation of electrical insulating materials.

49311230

Siemens Industry, Inc. Norcross, Georgia U.S.A.

**D**

40900057 0201 Rev.B

© 2009 Copyright Siemens Industry, Inc.