

SIEMENS

Indoor/Outdoor Service Entrance Module

Catalog Number

- WB11600B**
 WB11600BU

Enclosure

Type 3R

Module Rating:

1600 Amps Max; See main breaker for actual rating.
 Main Bus Rating: 1200 Amps Max (1200 Amps Max feed per side)
 120/240 Volts~, 1 Phase, 3 Wire
 208Y/120 Volts~, 1 Phase, 3 Wire (from 3 Phase, 4 Wire network)

For installation by Qualified Person in accordance with all local electrical codes and/or the National Electrical Code®.

Suitable Only For Use As Service Equipment unless bond strap is removed. Apply appropriate label provided next to breaker handle.

For underground service only.

Use 75°C Copper or Aluminum Conductors.

Terminals A, B and N:
 See Lug Chart on adjacent diagram for applicable lug kits, wire size and torque information.

Ground terminal G:
 Wire size #4-300 kcmil.
 Torque terminal to 250 lb.-in.

Circuit breaker trip position is indicated by handle position midway between ON and OFF. To reset, move handle to OFF position, then turn ON.

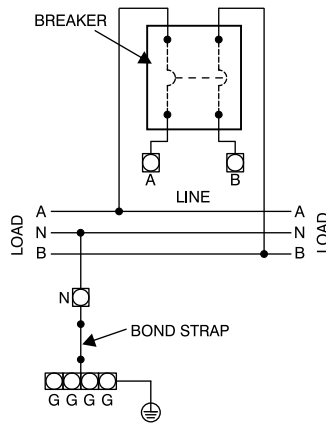

CAUTION

HAZARD OF ELECTRICAL OVERLOAD. Can result in personal injury or property damage. Mains that exceed 1200 Amps must be installed in the middle of the panelboard lineup with a maximum of 1200 amps exiting either side of the main device.

See adjacent labels for additional marking information.

49311233

Siemens Industry, Inc. Norcross, Georgia U.S.A.

D

409000590101 Rev.00

© The National Electrical Code is a registered trademark of the National Fire Protection Association.
 © 2019 Copyright Siemens Industry, Inc.

SIEMENS

Lugs for Phase and Neutral Connections (not supplied)

Lug No. ①	MFG	Wire Range	Type	No. Wires per phase	Torque (lb.-in.)
LK15600N2	Siemens	1/0-600 kcmil	Mechanical	5	500 ②
LK15750N2	Siemens	300-750 kcmil	Mechanical	5	500 ②
LK16750N2	Siemens	1/0-750 kcmil	Mechanical	6	500
2ACL-600	ILSCO	500 kcmil	Compression	5	NA ③
2ACL-750	ILSCO	750 kcmil	Compression	5	NA ③

- ① Order one mechanical lug kit for main breaker and neutral conversions. Contact lug manufacturer for compression lug quantities supplied for each kit.
 ② Kit contains more than one lug type.
 ③ See lug manufacturer's instruction sheet supplied with the connector for tool, die, and number of crimps.

Connect Modules Using: **Cat. No.** **Torque**
 Quick Connect QC1 400-440 lb-in (35-36 ft.-lb.)

IMPORTANT - for use with:

Module Description	Siemens Series#
Main Breakers	WB(M), WEB(M), WXB(M), BFT(M)
Switches	WMP, WS, WES, WXS
Tap/Terminal Boxes	WTB, WET, WT_PU, WTBN, WBT(M)
Pull Boxes	WMMB
Meter Module	(W)MM, (W)MT, (W)ML, (W)MK, (W)MLZ(F), (W)MN
Meter Combinations	WC, WCL, WCT,
Extension Box	WSP, WSPD
Bussed Elbow	BE, WELB

Short Circuit Current Rating

This device has a maximum short circuit current rating of 100,000 amps RMS symmetrical at 240 Volts ~. The actual short circuit current rating is limited to the interrupting rating of the circuit breaker installed. Replacement breakers must be manufactured by Siemens and must be of the correct type and rating as indicated in the table below. Use of other circuit breakers in this device will void the warranty.

Breaker Type	Rating
PXD6	65k AIC
HPXD6	100k AIC

USE ONLY NON-INTERCHANGEABLE TRIP BREAKER TYPES

Important: Do not allow petroleum based (hydrocarbon) sprays, chemicals, solvents or any paint to contact interior components. Petroleum based chemicals can cause degradation of electrical insulating materials.

Siemens Industry, Inc. Norcross, Georgia U.S.A.

D

409000590201 Rev.00

© 2019 Copyright Siemens Industry, Inc.