

SIEMENS

F2, 12 3/4" Deep FPP F672D Twin 200A Vacu-Break Mounting Kit

Installation
Instructions

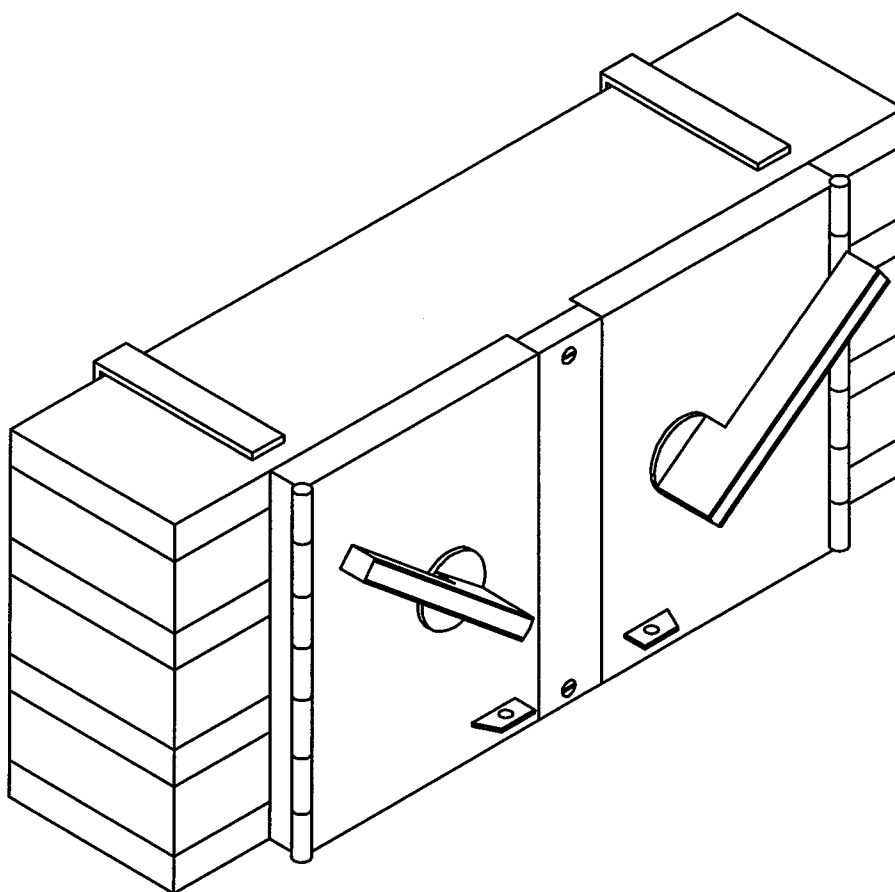

Installation Instructions

The following instructions are for the installation of a Siemens Twin 200A Vacu-Break in a type F2 and 12.75" deep FPP power panelboard. This device will require 10" of unit space. The parts provided in this kit are for connections to a 3 phase 3 or 4 wire system. For 3 phase 3 wire discard neutral lug and hardware (fig 9).



⚠ DANGER

High voltage.
Will cause severe injury or death.
 Qualified personnel only.
 Lock off power supplying this equipment before working inside.

1. Lock off all power supplying this equipment before working on it.
2. Reference fig. (1) Remove the (2) gutter covers and (2) ventilation covers .

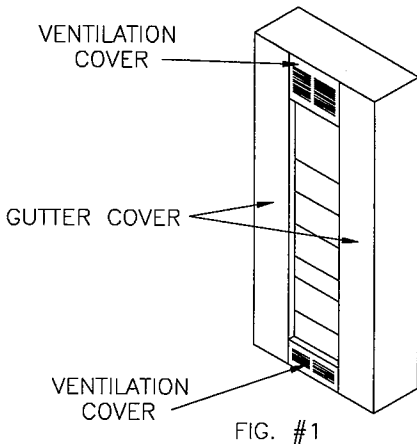

FIG. #1

- 3 Reference fig.(2) - To mount this switch in the panelboard, 10" of empty unit space is required. To locate the mounting position, measure from the top of the dead front support to the top of the empty unit space filler on the dead front. Transfer this dimension from the top of the dead front support along the Z-rail and mark. This will be the unit line as shown on (fig.4).

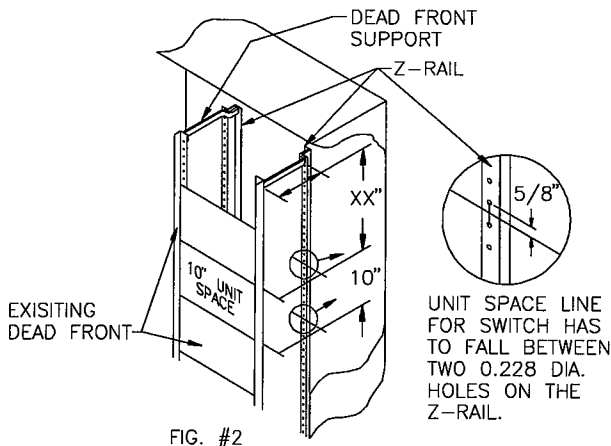

FIG. #2

4. Remove the Vacu-Break kit from the shipping box and check the hardware against the following list.

HARDWARE LIST

ITEM	DESCRIPTION	QTY.
1	200A TWIN VACU BREAK	
2	1/4-20 X 1/2 SLOTTED TRUSS SCREW	2
* 3	1/4" SPACER	2
4	MOUNTING HARDWARE KIT	1
5	1/4-20 X 3/8 SLOTTED HEX WASHER HEAD SCREW	8
6	350 KCMIL LUG	2
7	1/4-20 X 1/2 HEX HEAD MACH. SCREW	4
8	1/4 LOCK WASHER	4
9	1/4 FLAT WASHER	4
10	SWITCH CONNECTOR	3
11	SUPPORT BRACKET	4
* 12	5/16-18 X 1.5 SLOTTED HEX WASHER HEAD SCREW	3
* 13	1/4-20 X 1.00 SLOTTED HEX WASHER HEAD SCREW	2

* ITEMS COME WITH THE SWITCH.

5. Reference fig. (4) The first items to be installed will be the support bracket (item 11). Locate the mounting hole 5/8" down from the top of the 10" unit space and fasten the bracket to the Z-rail by using 1/4-20 x 3/8 thread forming screw (item 5), also connect the lower bracket up 5/8" from the bottom of the 10" unit space using the same hardware. Position the switch connectors (item 10) per fig.#4 and fasten them to the interior bus with 1/4-20 thread forming screws (item 4). See the mounting hardware for proper screw selection.

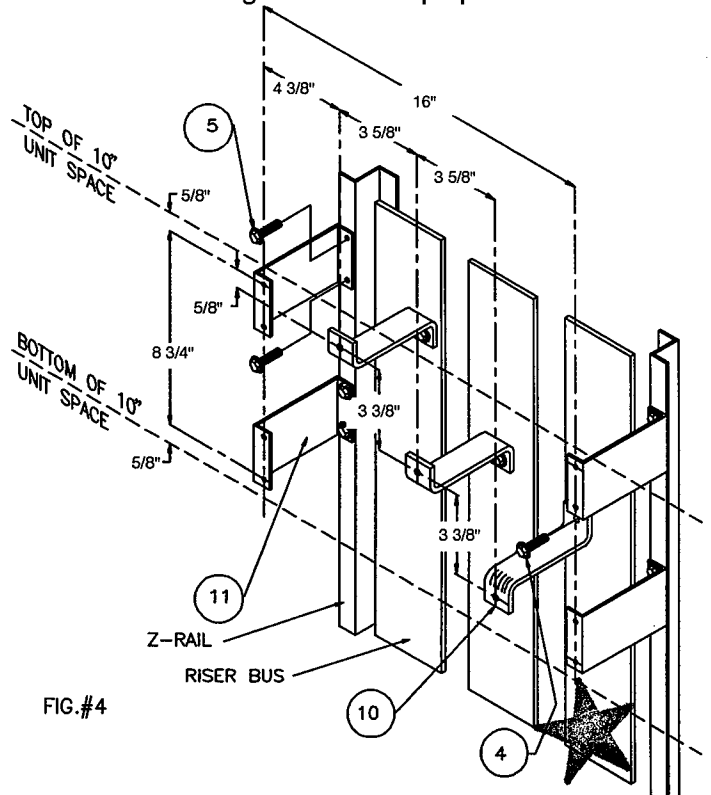

FIG.#4

6. Reference fig. (5) - Install items 2 and 3. Locate the upper support brackets (item 11) on both Z-rails. Insert the 1/4-20 x 1/2" truss screw (item 2) through the spacer (item 3) then into the top 7/32" diameter holes and tighten (Items 2 and 3 form a mounting stud).

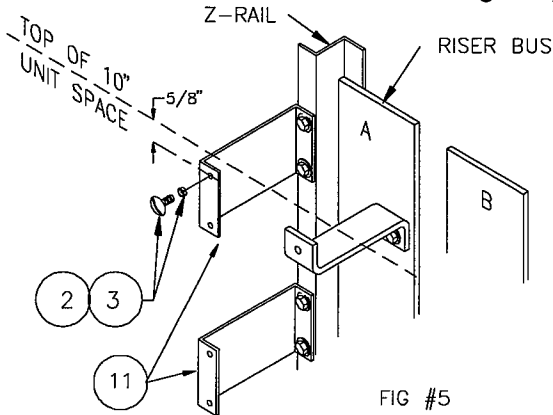

FIG #5

6. Reference fig. (6) - Located on back side of the switch are two support brackets. Each bracket has a 1/4" diameter hole and 3/8" open end slot. The open end slot is located near the top side of the switch. Line up the open end slots to the right side of the mounting stud located on the support bracket (item 11). Then slide the switch to the left onto the mounting stud. This will give the switch temporary support.

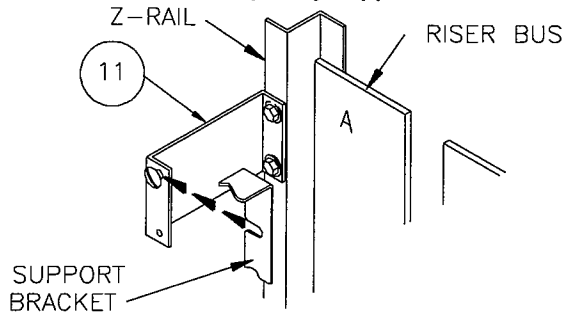

FIG. #6

7. Reference fig. (8) - Open both fuse compartment doors to locate the through holes for 1/4-20 x 1" thread forming screws (item 13). The through holes are inside, near the bottom left and bottom right corners of the switch. Insert 1/4-20 x 1" thread forming screws (item 13) into the through holes that line up with 7/32" diameter holes in the support bracket and then tighten. This will give the switch total support.

TO OPEN THE DOOR THE HANDLE MUST BE IN THE DOWN POSITION THEN SLIDE LOCK HASP LEFT OR RIGHT AND PULL ON HANDLE.

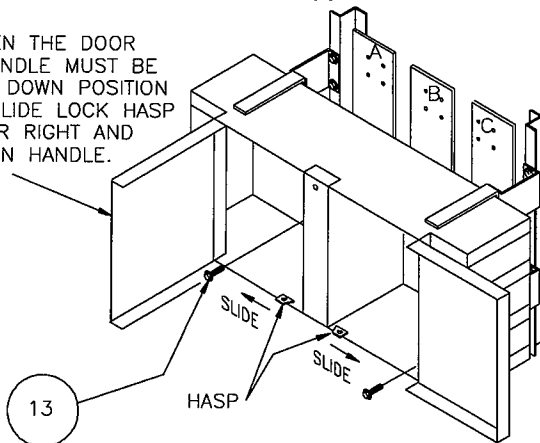

FIG.#7

9. Reference fig. (8) - With both fuse compartment doors open, locate the through hole for the A phase connection on the left side near the top and the C phase connection on the right side near the bottom. Attach with 5/16-18 x 1 1/2" hex washer head screw (item 12). For the B phase connection, remove the cover between the doors. Locate the through hole in the center of the opening. Attach with 5/16-18 x 1 1/2" hex washer head screw (item 12). Torque all connections to the values as specified on the label on the rear side of the dead front cover.

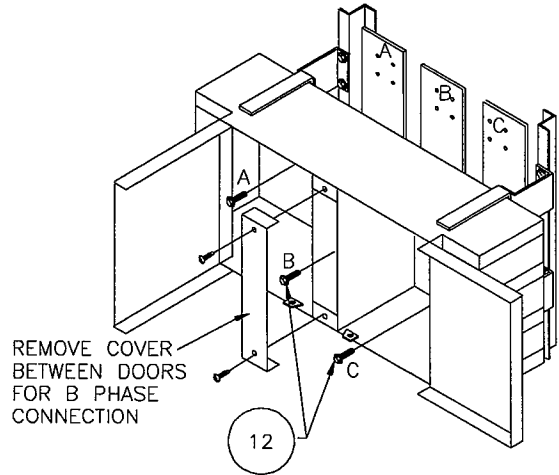

FIG.#8

10. Reference fig. (9) - On 3 phase 4 wire systems the Vacu-Break assembly kit will also require a neutral lug connection to the branch neutral located near the top or the bottom of the Z-rail. locate the "Z" shaped connector on the branch neutral and attach 350 komil lug (item 6) using 1/4-20 x 1/2" mach. screw (item 7) with 1/4" lock washer (item 8) and 1/4" flat washer (item 9).

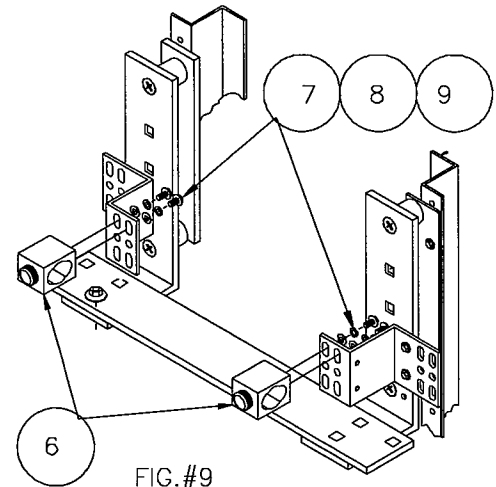

FIG.#9

