

Load Switch  
8 x 277 V AC, 20 Amp  
N 512 LCP3000EZ  
Data Sheet



# product GUIDE



**SIEMENS**

Global network of innovation

# Load Switch 8 X 277 V AC, 20 Amp N 512

**5WG1 512-1CB01**



### Product Description

The load switch N 512 is a N-system DIN-rail mounted device. Via its eight outputs, it can switch eight separate groups of electric devices. The power supply of the load switch N 512 is provided by the bus (i.e., it requires no additional power supply). The outputs may be operated manually via slide

switches. These switches also show the actual switching state (when switching manually as well as when switching via the bus). Each of the outputs (relays) can be assigned various tasks depending on the application program used, i.e. the load switch N 512 consists of the device (hardware) and its application programs (software).

## Technical Specifications

### POWER SUPPLY

Class 2 via bus line, 24V DC

**DEVICE RATING:**  
480V AC

### OUTPUTS

- Number: 8 contacts
- Rated voltage: 12 – 277V AC, 50 ... 60 Hz
- Rated current: 20 Amp.
- Switching characteristic: set in parameter list according to application program

### CONNECTIONS

- Load circuit: AWG# 14-12 solid or stranded Cu
- Bus line: One screw less bus connection block AWG #20–18 solid Cu, pressure contacts on data rail

### CONTROL ELEMENTS

- One learning button: for switching between normal operating mode and addressing mode
- Eight slide switches for manual operation

### PHYSICAL SPECIFICATIONS

- Housing: plastic
- N-system DIN-rail mounted device, width: 144 mm (5.67")
- Weight: approx. 560 gr
- Installation: rapid mounting on DIN EN 50022-35 x 7,5 rail

### DISPLAY ELEMENTS

- One red LED: for monitoring bus voltage and displaying mode, selected with the learning button
- Eight slide switches providing switching state information

### RELIABILITY

Reliability: 99.92% based on 1,000,000 units/10 years of operation under load

### ELECTROMAGNETIC COMPATIBILITY

Complies with Part 15 of the FCC rules pursuant to the limits for a Class A digital device

### ENVIRONMENTAL SPECIFICATIONS

- Ambient temperature operating: 23°F – 113°F (-5 + 45°C)
- Ambient temperature non-op.: -13°F – 158°F (-25... + 70°C)
- Relative humidity (non-condensing): 5% to 93%

### LISTINGS AND CERTIFICATIONS

UL listed (E173 174)  
UL 916, Energy Management Equipment

CSA certification (pending)

EIB certified

Complies with EMC regulations (residential and nonresidential buildings), and low voltage regulations

### Dimensional Drawings

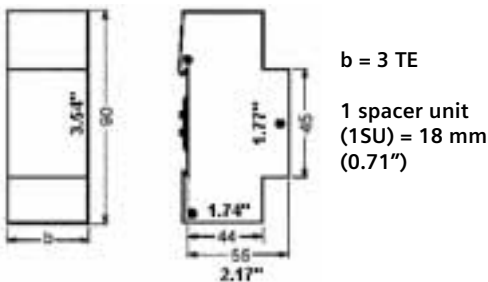

### Example of operation

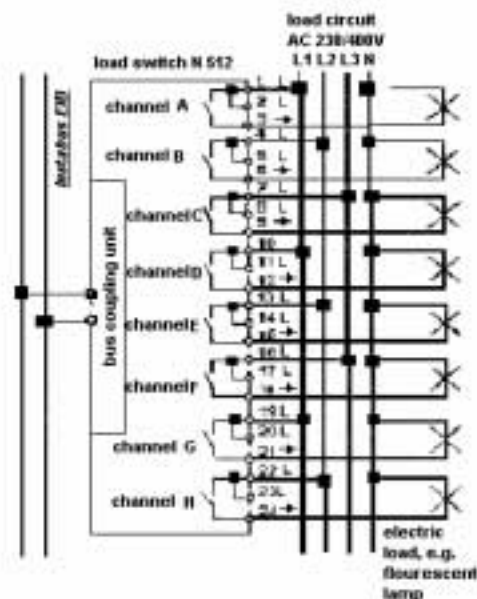

### WARNING

- The device may be built into distribution boards (230/400V) together with appropriate VDE-devices and must be mounted and commissioned by an authorized electrician.
- A safety disconnection of the device must be possible, especially if the device is connected.
- Free DIN rail areas with plugged in data rail must be covered with covers, order no. 5WG1192-8AA01.
- The prevailing safety rules must be heeded.
- The device must not be opened. A device suspected faulty should be returned to the local Siemens office.

## Installation Instructions

- The device may be used for permanent interior installations in dry locations within distribution boards.
- The load circuits must be protected with a 10 A miniature circuit breaker A or B characteristic.

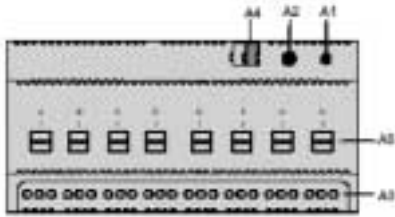

- A1** LED for indicating normal operating mode (LED off) and addressing mode (LED on); upon receiving the physical address the device automatically returns to normal operating mode
  - A2** Learning button for switching between normal operating mode and addressing mode
  - A3** Mains connection blocks (screw terminals) for connecting load circuits
  - A4** Bus connection block, screwless
  - A5** Slide switches for manual operation and for displaying the switching position  
Slide to position 1 : relay contact closed  
Slide to position opposite to 1 : relay contact open
- Manual operating of the switches will be overwritten by a switching command from the bus.

## Mounting

### General description

The N 512 is mounted to any DIN-rail (EN 50022- 35 x 7,5) available that has a data rail installed. The connection to the bus line is established by clicking the device onto the DIN-rail (with glued-in data rail). Take care that the type plates of all devices on a DIN-rail can be read in the same direction, guaranteeing the devices are polarized correctly.



Mounting and dismounting a DIN-rail device

### Mounting N 512 to a DIN-rail

- Slide the DIN-rail device (B1) onto the DIN-rail (B2).
- Swivel back the DIN-rail device until the slide clicks into place audibly.

## Dismounting N512 from a DIN-rail

- Remove all connected wires.
- Press down the slide (C3) with a screwdriver.
- Swivel the DIN-rail device (C1) from the DIN-rail (C2).

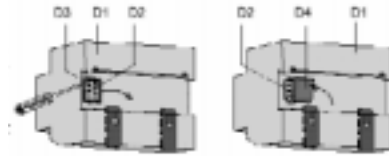

Removing the guiding top and inserting the insulation top

### Removing the guiding top

- The guiding top (D3) surrounds the contact system (D2) on the back side of the load switch N 512 (D1).
- Insert the screwdriver between the DIN-rail device (D1) and the guiding hood (D3) and remove the guiding hood.

### Inserting the insulation top

- Put the insulation top (D4) onto the contact system and click it into place using slight pressure.

## Wiring

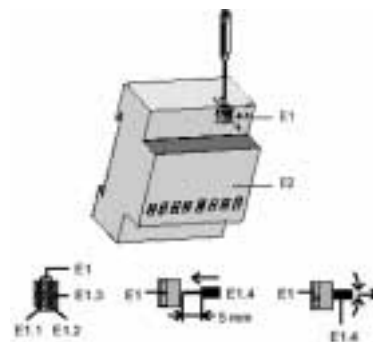

Connecting and disconnecting bus wires

### Slipping off bus connection blocks

- The bus connection block (E1) is situated on the top of the N 512 (E2).
- The bus connection block (E1) consists of two components (E1.1 and E1.2) with four terminal contacts each. Take care not to damage the two test sockets (E1.3) by accidentally connecting them to the bus cable or with the screwdriver (e.g. when attempting to unplug the bus connection block).
- Carefully put the screwdriver to the wire-inserting slit of the bus connection block's grey component and pull the bus connection block (E1) from the loadswitch N 512 (E2).

## Note:

Don't try to remove the bus connection block from the bottom side! There is a risk of shorting-out the device!

### Slipping on bus connection blocks

Slip the bus connection block onto the guide slot and press the bus connection block (E1) down to the stop.

### Connecting bus cables

- The bus connection block (E1) can be used with single core conductors 18 AWG.
- Remove approx. 5 mm (0.19") of insulation from the conductor (E1.4) and plug it into the bus connection block (E1) (red = +, black = -).

### Disconnecting bus cables

Unplug the bus connection block (E1) and remove the bus cable conductor (E1.4) while simultaneously wiggling it.

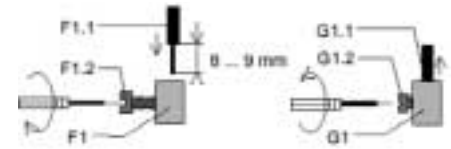

Connecting and disconnecting load circuits

### Connecting load circuits

- Remove approx. 8 to 9 mm (0.31"-0.35") of insulation from the wire (F1.1) and plug it into the terminal (F1) and tighten the screws (F1.2)
- Cross sections load circuit, physical: strip insulation for 8... 9 mm (0.31"-0.35") permissible conductor types/cross sections:  
- 12 AWG or 14 AWG single core

### Disconnect load circuits

- Release the screw (G1.2) and remove the wire (G1.1) from the terminal (G1).

### Important hint:

The manual operation of the sliding switches is only designated as an emergency operation. There is no telegram downloaded to the bus and the changed position is not recognized by the bus controller. In case of bus voltage failure/recurrence even the switching conditions of manually controlled relays resume the condition set in parameter list.





**Load Switch 8 X 277 V AC, 20 Amp  
N 512**

**5WG1 512-1CB01**

**Siemens Energy & Automation, Inc.**

Power Distribution Solutions  
3333 Old Milton Parkway  
Alpharetta, GA 30005

For more information, call **1-800-427-2256**  
or visit **[www.sea.siemens.com](http://www.sea.siemens.com)**

© 2004 Siemens Energy & Automation, Inc. All Rights Reserved

Siemens is a registered trademark of Siemens AG. Product names mentioned may be trademarks or registered trademarks of their respective companies. Specifications are subject to change without notice.