

Selection and Application Guide
2004



compelling
FLEXIBLE

LCP3000EZ
Lighting Control



SIEMENS

Global network of innovation

SIEMENS

LCP3000EZ Lighting Control System



instabus EIB Technology
Overview

1

System Overview

2

Selection Process

3

E-Z-Config Tool

4

System Components

5





LCP3000EZ Lighting Control System

1

About This Guide

This Selection and Application Guide helps you select the correct number of LCP3000EZ panels, inputs, outputs and accessories to fit your lighting control application.

Organization

- **System Overview** – provides an introduction into the lighting control system based on *instabus* EIB.

- **Technical Description** – explains the *instabus* architecture and technology.
- **Selection Process** – explains the step-by-step process for planning and designing a new or retrofit lighting control system.
- **E-Z-Config Tool** – describes the Palm OS based configuration tool, which can also be run on a PC using an emulator.

- **Information Forms** – support gathering information about the desired lighting control system function and layout.
- **System Components** – data sheets for all components used in the Siemens *instabus* Lighting Control System LCP3000EZ.

Forms

These forms are an essential part of the application selection process. The forms can be found on the Web: <http://www.sea.siemens.com/power/product/pdpprodic.html>

Before proceeding, take a moment to make several photocopies of the forms.

instabus EIB Technology Overview

Greater demand for flexibility, ease of installation and lower energy consumption have led to the development of lighting control and building management systems.

EIB is a standardized bus technology (ANSI EIA 776, EN 50090) used world-wide for these systems. The SIEMENS LCP3000EZ lighting control panels take full advantage of the *instabus* EIB technology.

Advantages

In conventional lighting control systems, each function needed its own wiring and each control system its own separate power supply. With *instabus*, however, all operating functions and procedures can be controlled, monitored and signaled via a single shared twisted pair cable.

In addition to the reduced number of cables and wiring, there are other advantages: Initial installation is much simpler and, later, it can be extended or modified without difficulty. The LCP3000EZ Lighting Control Panels can be quickly and easily updated for new configurations or rearranged layouts simply by reassigning (reconfiguring) the bus devices. And it is not necessary to add any new wiring.

The LCP3000EZ Lighting Control Panels also can be connected to building automation systems. This means that the LCP3000EZ Lighting Control Panels can be used as economically in private homes as in hotels, schools, banks, office buildings or building complexes.

Because of these advantages, *instabus* has been used in

over 100,000 installations world-wide with more than 10 million deployed devices.

Transmission

instabus is a decentralized, event controlled bus system with serial data transmission. All connected bus devices can exchange information with each other through the shared transmission route (the bus).

Data is transmitted serially and according to fixed rules (bus protocol). This involves packing information into a telegram and transporting it via the bus from one sensor (control station) to one or more actuators (receivers).

Technology

There is no centralized control unit; each device has its own operational program which is stored in non-volatile memory. This removes the possibility of a complete

system shut down, which can occur on conventional systems when the main logic board fails.

The power supply provides individual line devices with 24V DC Class 2 power (safety extra low voltage, SELV) with a maximum current of 320mA. It has power and current limiters and is thus short-circuit-proof.

Short network interruptions are bridged with 100ms stored-energy time.

The twisted pair cable length of a line, including all branches, must not exceed 3300' (1000 m.).

LCP3000EZ Lighting Control System

System Overview

2

The LCP3000EZ Lighting Control System is fully modular in design. In its basic form, it consists of ten networkable low voltage relay control panels.

Each panel contains microprocessor controlled input or control relay modules, each containing an individual microprocessor. Each panel offers 8, 16, 24 or 32 programmable switch inputs and 8, 16, 24, 32, 40 or 48 programmable control relays.

A set of up to ten panels with a total of up to 320 inputs and 480 relay outputs is networkable without using communication or networking cards in any of these ten panels. Each panel contains an RS 232 interface module for access to and configuration of any of the ten control panels. The set of up to ten panels consists of a base panel and up to nine expansion panels. The base panel is marked as Panel A, the expansion panels are marked as Panel B, Panel C, Panel D, Panel E, Panel F, Panel G, Panel H, Panel J and Panel K.

Panel A (first panel) provides up to 32 programmable switch inputs, up to 48

programmable control relays, an RS 232 interface module for access to and configuration of any of the set of ten control panels, a time-clock with four time channels and a power supply. Optionally, Panel A provides a time-clock with sixteen time channels instead of four time channels. Optionally, Panel A is expandable with either a Dual Sensor for outdoor ambient light level and temperature reading, or with a Touch Panel user control interface for Panel A, or with an administrator Touch Panel, or with a key switch, or with up to two motion sensors, or with an IP Interface for Internet Protocol access via LAN or modem to the lighting control system. These options are added without using any of the programmable switch inputs on any of the panels.

Each expansion panel (Panel B to K) provides up to 32 programmable switch inputs, up to 48 programmable control relays, an RS 232 interface module for access to and configuration of any of the set of ten control panels. Optionally, each expansion panel is expandable with either a Touch Panel user control interface for this panel, or with up to two

motion sensors. These options are added without using any of the programmable switch inputs on any of the panels.

Each individual control relay provides an optional timer function with output timers for 30, 60, 90, 120, 180 or 240 minutes. Each individual control relay provides an optional Warn Off (flash the lights) to inform the occupants of an impending Off command. The Warn Off command provides a time duration of 5 extra minutes. The occupants may exit the premises with adequate lighting or cancel the Warn Off by overriding the lighting zone. This option occurs with all OFF commands except local overrides. Each individual control relay permits lighting to be overridden ON for after hours use or cleaning. The control system provides timed overrides assigned to specific relays. Override times may be configured to 30, 60, 90, 120, 180 or 240 minutes. Once the timed override expires, the control system returns the relays to their programmed state. These overrides are hard-wired inputs. Each control relay output provides a logic control function for logic (AND,

OR) combination of inputs controlling the output relay. Logic AND control enables or disables an output relay based on Time-Of-Day scheduling or any input in the system. Logic OR control provides forced ON control of an output relay by Time-Of-Day scheduling or from any input in the system.

Configuring the control system is through a Palm OS or PC based configuration software. The Palm OS device or PC may be connected to any panel in the control system via the RS 232 interface module. Descriptive information assists the user to employ the system without a programming manual.

The control system provides networking between sets of up to ten lighting control panels without adding communication or networking cards in each of these ten panels. Sets of up to ten lighting control panels are wired to the same line (twisted pair network). Using the IP Interface option, networking between lines is possible via LAN and a SCADA system. This control system network may support up to 500 control panels.

LCP3000EZ Lighting Control System



Selection Process

3

3/2

Lighting Control

Selection Process

Part 1: Plan the Project

Selecting LCP3000EZ Panels and Accessories

This section describes the application selection process for the Siemens LCP3000EZ Lighting Control System.

Application selection is a two-part process in which you:

1. Plan the project.
2. Design the project.

Each part of the process includes several steps. All steps are required for most projects.

3. Identify application and function issues.

Step 1: Determine the application requirements and objectives

This step answers the question, "Why is a lighting control system being specified?"

You can gain insights into the application requirements by:

- Reviewing blueprints or other documents
- Talking to the client or the client's representative about how the space will be used.
- Talking to the client or the client's representative about their goals for lighting control.

NOTE: To fully utilize the capabilities of the LCP3000EZ read the Technical Description to make yourself familiar with the system.

Step 2: Determine how rooms or buildings will be used

This information is essential for developing a good design. You can determine how an area will be used by

asking the following questions:

- Is this new or retrofit construction?
- Does the system extend outdoors?
- Who are the occupants?
- What needs to be controlled?
- How much control is required?
- Who needs to control the system?
- What future changes are planned or should be possible without rewiring?

Step 3: Identify application and function issues.

This step allows you to decide what features and control mechanisms to build into the system.

You can determine the requirements by asking the following questions:

- How many switching groups are required?
- Where can the panels be mounted?
- Where will wall switches be mounted?
- Is security lighting required?
- How are functions to be controlled?
- Which functions should be linked?
- What are the higher priority functions?
- Will the system be monitored remotely or locally?

NOTE: Use the Information Forms to gather this data. Information forms can be found in our Web page: <http://www.sea.siemens.com/power/product/pdprodlc.html> Also see blank form samples on the next pages.

Selection Process

Part 2: Design the Project

System design involves selecting the topology and components that best meet the requirements identified during the planning process. During planning, follow these guidelines:

- System supports a decentralized structure regardless of system size.
- System adapts to new functions easily.
- Up to 10 panels can be combined in one system.
- A system of any size has a four channel time clock; a 16 channel time clock is optional.
- The standard enclosures are for surface mounting and have a non key lock.
- Flush mounting kit and key lock are optional.
- Each panel can have up to 48 outputs, 32 digital (dry contacts) inputs,

two motion detectors, one outdoor light and temperature dual sensor and one LCD touch panel.

- Control can be time dependent, light dependent, motion dependent or a combination.

System design involves several steps:

- **Step 1: Determine the number of lighting control panels in the system.** The Information Forms help determine the number of panels. Each panel may have up to 32 inputs and 48 output relays each panel in the system has a separate catalog number. (see 10th digit in the catalog number)
- **Step 2: Determine panel location in the building.**

Lighting Control Panel should be mounted adjacent to the panelboard feeding the load.

• Step 3: Determine catalog number

a. Determine number of output modules in each panel (last digit in catalog number). Divide the number of outputs per panel by 8 and round up to the next integer.
Example: 9 output relays are required. Then insert two (2) for the outputs in the order number for that panel. Number of output modules determines number of rails (7th digit in catalog number)

b. Determine number of switch inputs (digital inputs /dry contacts)

Divide the number of inputs per panel by 8 and round up to the next integer.
Example: 7 inputs are required. Then insert one (1) for the inputs in the order number for that panel.

- **Step 4: Select control accessories (ordered separately)**
 - Motion sensor (up to two per panel)
 - Dual sensor (outdoor light level and temperature)
 - 4 or 16 channel time clock
 - IP connectivity/WebAccess operation
 - Master touch panel
 - Touch panel (one per panel)
- **Step 5: Choose enclosure options**
 - Flush mount
 - Key lock

Information Form Sample 1 - Relay Outputs

Panelboard	Ckt	Relay	RELAY OUTPUTS				LCP3000EZ	Relay
			Description	Control	Logic	Manual Override		
		1					001	A
		2						B
		3						C
		4						D
		5						E
		6						F
		7						G
		8						H
		9						A
		10						B
		11						C
		12					002	D
		13						E
		14						F
		15						G
		16						H
		17						A
		18						B
		19						C
		20					003	D
		21						E
		22						F
		23						G
		24						H

Lighting Control

Information Form Sample 1 - Relay Outputs

Panelboard	Ckt	Relay	RELAY OUTPUTS				Relay Module	Relay
			Description	Control	Logic	Manual Override		
		25					004	A
		26						B
		27						C
		28						D
		29						E
		30						F
		31						G
		32						H
		33					004	A
		34						B
		35						C
		36						D
		37						E
		38						F
		39						G
		40						H
		41					006	A
		42						B
		43						C
		44						D
		45						E
		46						F
		47						G
		48						H

Lighting Control

LCP3000EZ
Lighting Control System

Information Form Sample 2- Time Clock Schedules (Weekly)

Time Clock Schedules (Weekly Schedule)															
Schedule Number	Description	Monday		Tuesday		Wednesday		Thursday		Friday		Saturday		Sunday	
		On/Off	time	On/Off	time	On/Off	time	On/Off	time	On/Off	time	On/Off	time	On/Off	time
1															
2															
3															
4															
5															
6															

Lighting Control

Information Form Sample 2 - Time Clock Schedules (Weekly)

Schedule Number	Description	Time Clock Schedules (Weekly Schedule)																									
		Monday				Tuesday				Wednesday				Thursday				Friday				Saturday				Sunday	
		On/Off	time	On/Off	time	On/Off	time	On/Off	time	On/Off	time	On/Off	time	On/Off	time	On/Off	time	On/Off	time	On/Off	time	On/Off	time	On/Off	time		
7																											
8																											
9																											
10																											
11																											
12																											

Selection Process

Part 3: Determine Catalog Numbers

NOTE: To make this task easier, SIEMENS offers a software tool. Ask your SIEMENS sales person or distributor for assistance with it.

LCP3000EZ Catalog Numbering System

(Determined by the number of outputs and output provisions)

Catalog No.
5WG1 70 -8X

Number of Rails

- 3 (24" high) (16 outputs maximum)
- 4 (32" high) (32 outputs maximum)
- 5 (40" high) (48 outputs maximum)

Panel Designation

- A 1st panel in a system
- B 2nd panel
- C 3rd panel
- D 4th panel
- E 5th panel
- F 6th panel
- G 7th panel
- H 8th panel
- J 9th panel
- K 10th panel

(8 switch inputs per number)

Number of Switch Input Modules

- 0
- 1
- 2
- 3
- 4

(8 outputs per module)

Number of Output Modules

- 1
- 2
- 3
- 4
- 5
- 6

Final step: select accessories and options. (ordered separately - see next page - 3/8)

Lighting Control

LCP3000EZ
Lighting Control System

Selection Process

Part 3: Determine Catalog Numbers

LCP3000EZ Catalog Numbering (Accessories)

5WG1 703-8XX00	Flush mount kit for 20" X 24" box with 3 7.5 mm deep DIN Rails
5WG1 704-8XX00	Flush mount kit for 20" X 32" box with 4 7.5 mm deep DIN Rails
5WG1 705-8XX00	Flush mount kit for 20" X 40" box with 5 7.5 mm deep DIN Rails
5WG1 700-8XX00	Key lock kit for all panels
5WG1 372-5EY01-Z-A201	4 channel time clock
5WG1 373-5EY01-Z-A202	16 channel time clock
5WG1 255-2AB11	Motion sensor
5WG1 114-2AB02-Z-A221	Wall mounted bus coupler for motion sensor(s), Panel A
5WG1 114-2AB02-Z-A231	Wall mounted bus coupler for motion sensor(s), Panel A
5WG1 114-2AB02-Z-B222	Wall mounted bus coupler for motion sensor(s), Panel B
5WG1 114-2AB02-Z-B232	Wall mounted bus coupler for motion sensor(s), Panel B
5WG1 114-2AB02-Z-C223	Wall mounted bus coupler for motion sensor(s), Panel C
5WG1 114-2AB02-Z-C233	Wall mounted bus coupler for motion sensor(s), Panel C
5WG1 114-2AB02-Z-D224	Wall mounted bus coupler for motion sensor(s), Panel D
5WG1 114-2AB02-Z-D234	Wall mounted bus coupler for motion sensor(s), Panel D
5WG1 114-2AB02-Z-E225	Wall mounted bus coupler for motion sensor(s), Panel E
5WG1 114-2AB02-Z-E235	Wall mounted bus coupler for motion sensor(s), Panel E
5WG1 114-2AB02-Z-F226	Wall mounted bus coupler for motion sensor(s), Panel F
5WG1 114-2AB02-Z-F236	Wall mounted bus coupler for motion sensor(s), Panel F
5WG1 114-2AB02-Z-G227	Wall mounted bus coupler for motion sensor(s), Panel G
5WG1 114-2AB02-Z-G237	Wall mounted bus coupler for motion sensor(s), Panel G
5WG1 114-2AB02-Z-H228	Wall mounted bus coupler for motion sensor(s), Panel H
5WG1 114-2AB02-Z-H238	Wall mounted bus coupler for motion sensor(s), Panel H
5WG1 114-2AB02-Z-J229	Wall mounted bus coupler for motion sensor(s), Panel J
5WG1 114-2AB02-Z-J239	Wall mounted bus coupler for motion sensor(s), Panel J
5WG1 114-2AB02-Z-K230	Wall mounted bus coupler for motion sensor(s), Panel K
5WG1 114-2AB02-Z-K240	Wall mounted bus coupler for motion sensor(s), Panel K
5WG1 588-2CB11-Z-A210	Master Touch Panel
5WG1 588-2CB11-Z-A211	Panel A, Touch Panel
5WG1 588-2CB11-Z-B212	Panel B, Touch Panel
5WG1 588-2CB11-Z-C213	Panel C, Touch Panel
5WG1 588-2CB11-Z-D214	Panel D, Touch Panel
5WG1 588-2CB11-Z-E215	Panel E, Touch Panel
5WG1 588-2CB11-Z-F216	Panel F, Touch Panel
5WG1 588-2CB11-Z-G217	Panel G, Touch Panel
5WG1 588-2CB11-Z-H218	Panel H, Touch Panel
5WG1 588-2CB11-Z-J219	Panel J, Touch Panel
5WG1 588-2CB11-Z-K220	Panel K, Touch Panel
5WG1 254-3EY01-Z-A203	Outdoor ambient light level sensor
5WG1 220-2CB02-Z-A204	Key switch
5WG1 146-3AB01-Z-A251	Web access operation and control



5WG1 373-5EY01-Z-A202
16 channel time clock



5WG1 254-3EY01-Z-A203
Outdoor ambient light level sensor



5WG1 146-3AB01-Z-A251
Web access operation and control

LCP3000EZ Lighting Control System

4



LCP3000EZ E-Z-Config Tool

EZC		A-002			
		A	B	C	D
		C ≥ M	C ≥ M	C ≥ M	C ≥ M
A	S	✓			✓
B	S		✓		✓
C	S			✓	
D	S			✓	
B-111		(DONE)			

The LCP3000EZ E-Z-Config Tool is a software program developed by SIEMENS to allow installers to easily configure the LCP3000EZ lighting control system. It is distributed free of charge with every system.

What is needed:

PALM Pilot with the following requirements:

- Palm OS 3.5 or higher
- 2MB RAM or more
- Serial interface RS 232 or a Windows based PC with Palm Emulator software installed. This is also distributed free of charge with every system.

The LCP3000EZ E-Z-Config Tool allows:

- Configure and download functions to a system.
- Upload an existing configuration from a system.
- Test the configuration.
- Operate the relays one at a time or as a block.
- Read relay status.
- Operate relays using linked inputs.
- Read outdoors light level.



LCP3000EZ Lighting Control System

5



System Components

Enclosures

5/2

Internally Mounted Devices:

Load Switch N 512 5/3

Switch Inputs N 261 5/4

Annual Scheduler REG 372 5/5

Annual Scheduler REG 373 5/6

Power Supply N 123 5/7

Choke N 120 5/8

Line/Backbone Coupler N 140 5/9

RS 232 Interface N 148 5/10

Connector REG 191 5/11

Accessories: 192 Cover Strip, 193 Plug in connector,
190 Data Rail. 5/12

Externally Mounted Devices:

Dual Sensor AP 254 5/13

Bus Coupling Unit UP 114 5/14

Motion Detector UP 255 5/15

Switch Interface UP 220 5/16

Touch Panel Vision UP 588 5/17

Ethernet Interface AP 146 5/18

Enclosures

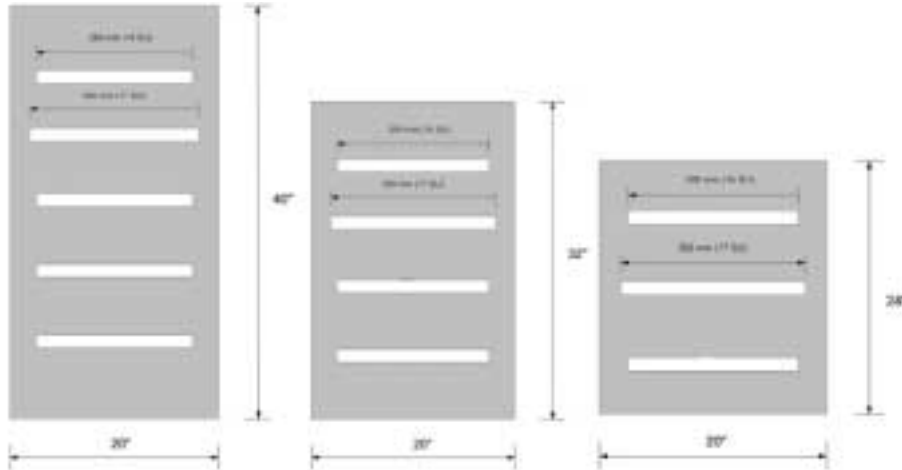

The Siemens *instabus* lighting control panel supports the system components and other panel mounted devices. All panel mounted devices

snap into DIN rails. An integral data rail provides 24V DC power and communications to the system. The lighting control panel enclosures

are 20 inches in width and either 24, 32 or 40 inch high. Flush-mount and surface-mount enclosures (5 3/4 inch deep) are available for new or retrofit

construction. All lighting control panels are as freestanding units.

Height	Description	Catalog Number
24"	Freestanding, surface mount enclosure	11-D-2275-01
32"	Freestanding, surface mount enclosure	11-D-2276-01
40"	Freestanding, surface mount enclosure	11-D-2277-01
24"	Flush mount kit	11-D-2278-01
32"	Flush mount kit	11-D-2279-01
40"	Flush mount kit	11-D-2280-01
N-A	Key lock kit	11-D-2281-01



Lighting Control

LCP3000EZ
Lighting Control System

Load Switch N 512 8 x 230 VAC, 20 Amp



The load switch N 512 is a N-system DIN rail mounted device. Via its eight outputs, it can switch eight separate groups of electric devices. The power supply of the load switch N 512 is provided by the bus (i.e., it requires no additional power supply). The outputs may be operated manually via slide switches. These

switches also show the actual switching state (when switching manually as well as when switching via the bus). Each of the outputs (relays) can be assigned various tasks depending on the application program used, i.e. the load switch N 512 consists of the device (hardware) and its application programs (software).

Dimension Diagrams

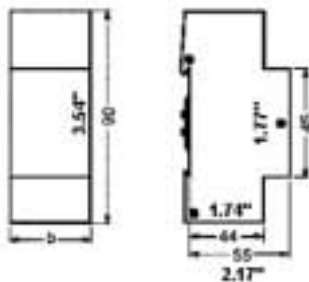

- Dimensions in mm and inches

Typical Circuit

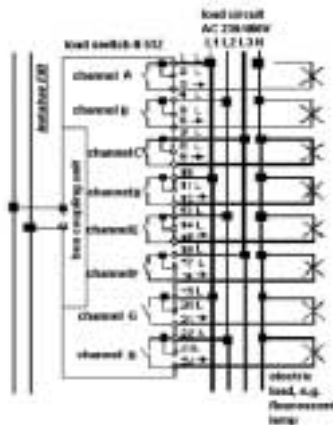

Order No.

5WG1 512-1CB01

Technical Data

Power supply	Class 2 via bus line, 24V DC
Device Rating	480 V AC
Outputs	Number: 8 contacts Rated voltage: 12 – 277V AC, 50... 60 Hz Rated current: 20 Amp. Switching characteristic: set in parameter list according to application program
Control Elements	One learning button: for switching between normal operating mode and addressing mode Eight slide switches for manual operation
Display Elements	One red LED: for monitoring bus voltage and displaying mode, selected with the learning button Eight slide switches providing switching state information
Connections	Load circuit: AWG# 14-12 solid or stranded Cu bus line: One screw less bus connection block AWG #20 –18 solid Cu, pressure contacts on data rail
Physical Specifications	Housing: plastic N-system DIN rail mounted device, width: 144 mm (5.67") Weight: approx. 560 gr Installation: rapid mounting on DIN EN 50022-35 x 7.5 rail
Reliability	99.92% based on 1,000,000 units/10 years of operation under load
Electromagnetic Compatibility	Complies with Part 15 of the FCC rules pursuant to the limits for a Class A digital device
Environmental Specifications	Ambient temperature operating: 23°F – 113°F (-5... +45°C) Ambient temperature non-op.: -13°F – 158°F (-25... +70°C) Relative humidity (non-condensing): 5 % to 93
Listings and Certifications	UL listed (E173 174) UL 916, Energy Management Equipment Accessory CSA certification (pending) EIB certified CE Mark Complies with EMC regulations (residential and nonresidential buildings) and low voltage regulations

Binary Input N 261 8 x 120 VAC, 20 Amp



The binary input N 261 is a N-system DIN rail mounted device with four inputs. The required voltage must be provided by an additional 24V AC or 24V DC power supply unit. Each of the inputs can be assigned various tasks depending on the application program used, i.e. the binary input N 261 consists of the device

(hardware) and its application programs (software). Appropriate application programs are available for the different tasks the binary input N 261 can handle; e.g. sending of ON and OFF messages at different edges of the input signal either event-controlled or cyclic with programmable repetition.

Order No. 5WG1 261-1CB01

Dimension Diagrams

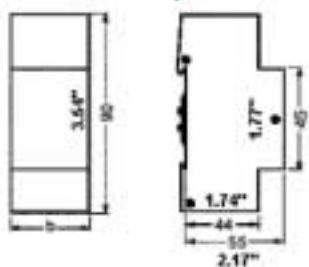

- Dimensions in mm and inches

Typical Circuit

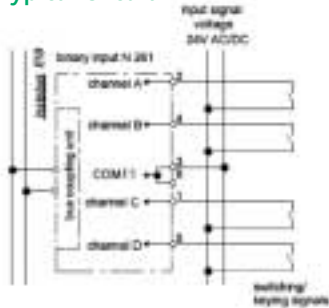

Technical Data

Power supply	Class 2 via bus line, 24V DC
Inputs	<p>Number: 4 inputs</p> <p>Input signal voltage:</p> <ul style="list-style-type: none"> - Rated value: 24V AC/DC - Frequency: 47... 63 Hz (at 24V AC) - Signal "0": -30... +5V DC, 0... 5V AC - Signal "1": +10... +30V DC, 10... 30V AC <p>Input current:</p> <ul style="list-style-type: none"> - At "1": usually 3.5 mA (at 24V AC) and, 6 mA (at 24V DC) <p>Input signal length: min. 50 ms</p> <p>Input characteristic: set in parameter list according to application program</p>
Control Elements	<p>Length of input signal cable: max. 110 yards (100 m)</p> <p>One learning button: for switching between normal operating mode and addressing mode</p>
Display Elements	1 red LED: for monitoring bus voltage and displaying mode, selected with the learning button
Connections	<p>Signal inputs, screwless plug-in terminals</p> <p>Load circuit: AWG # 20-14 solid Cu</p> <p>Bus line: bus line: One screw less bus connection block AWG #20-18 solid Cu, pressure contacts on data rail</p>
Physical Specifications	<p>Housing: plastic</p> <p>N-system DIN rail mounted device, width: 1.42" (36 mm).</p> <p>Weight: approx. 0.33 lb (150 gr)</p> <p>Installation: rapid mounting on DIN EN 50022-35 x 7.5 rail</p>
Reliability	99.92% based on 1,000,000 units/10 years of operation under load
Electromagnetic Compatibility	Complies with Part 15 of the FCC rules pursuant to the limits for a Class A digital device
Environmental Specifications	<p>Ambient temperature operating: 23°F – 113°F (-5... +45°C)</p> <p>Ambient temperature non-op.: -13°F – 158°F (-25... +70°C)</p> <p>Relative humidity (non-condensing): 5% to 93%</p>
Listings and Certifications	<p>UL listed (E173 174)</p> <p>UL 916, Energy Management Equipment Accessory</p> <p>CSA certification (pending)</p> <p>EIB certified</p> <p>CE Mark</p> <p>Complies with EMC regulations (residential and nonresidential buildings) and low voltage regulations</p>

Lighting Control

LCP3000EZ
Lighting Control System

Annual Scheduler REG 372



The 4-channel time switch REG 372 (annual scheduler) is a DIN rail mounted device for mounting in distribution boards. The connection to system is made via a bus connector. The time switch offers: 324 switching times for selectable daily, weekly and date instructions, impulse instructions, priority switching times, as well as 1 x instructions for vacation / holidays. For each channel, additionally 9

further week programs with priority levels P1 to P9 and a time-limited permanently switched circuit can be programmed besides the normal week program. Likewise a random program can be activated. The period of a priority program is determined by input of a beginning and final date. The time switch calculates moving holidays (like Easter) automatically for each year.

Dimension Diagrams

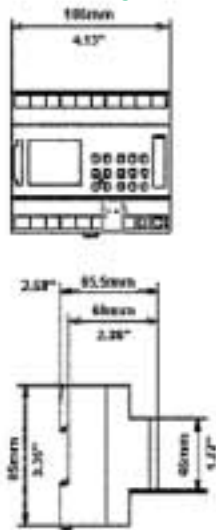

- Dimensions in mm and inches

Typical Circuit

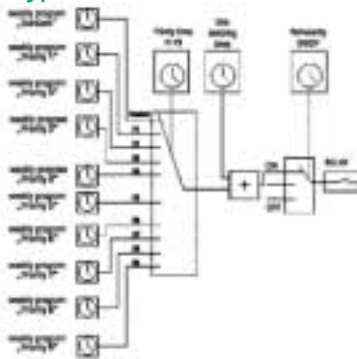

Order No.

5WG1 372-5YE01

Technical Data

Power supply	Class 2 via bus line, 24V DC. Consumption: 8 mA (at bus voltage)
Inputs	4 channels Time base: quartz precision 322 memory locations in EEPROM Shortest switching interval: 1 second / minute switching accuracy: 1 second Shortest impulse 1 second Time accuracy: ± 1 Sec./ at 68°F (20°C) Power reserve: Lithium battery 10 years at 68°F (20°C) Type of Lithium battery: CR 2450 Daily, weekly, yearly and impulse programs as automatic programs Manual overrides - Temporary manual override - Permanent manual override Programming: Via 10-key keyboard or with PC Obelisk software and Obelisk memory card Block formation: Free block formation of week days and channels Automatic Summer / Winter time changeover
Control Elements	One learning button: for switching between normal operating mode and addressing mode 15 soft touch buttons: for setting day of week, hour, minute, time, program entry and 2 manual overrides
Display Elements	One red LED: for monitoring bus voltage and displaying mode, selected with the learning button. LC Display: for display of time, day of week, daylight savings mode, holiday program mode, switching status and manual control mode
Connections	Bus line: screw-less bus connection block
Physical Specifications	Polymer casing DIN rail mounted device Weight: 0.75 lb (337 g) installation: rapid mounting on DIN EN50022-35 x 7.5 rail
Reliability	99.92% based on 1,000,000 units/10 years of operation under load
Electromagnetic Compatibility	Complies with Part 15 of the FCC rules pursuant to the limits for a Class A digital device
Environmental Specifications	Ambient temperature operating: 23°F – 113°F (-5... +45°C) Ambient temperature non-op.: -13°F – 158°F (-25... +70°C) Relative humidity (non-condensing): 5 % to 93
Listings and Certifications	EIB certified CE Mark Complies with EMC regulations (residential and nonresidential buildings) and low voltage regulations

Annual Scheduler REG 373

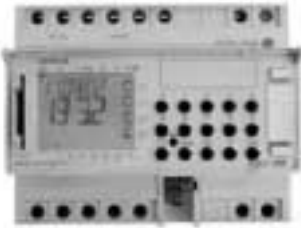

The 16-channel time switch REG 373 (annual scheduler) is a DIN rail mounted device for mounting in distribution boards. The connection to system is made via a bus connector. The time switch offers: 500 switching times for selectable daily, weekly and date instructions, impulse instructions, priority switching times, as well as 1 x instructions for vacation / holidays. For each channel, additionally 9

further week programs with priority levels P1 to P9 and a time-limited permanently switched circuit can be programmed besides the normal week program. Likewise a random program can be activated. The period of a priority program is determined by input of a beginning and final date. The time switch calculates moving holidays (like Easter) automatically for each year.

Dimension Diagrams



- Dimensions in mm and inches

Order No.

5WG1 373-5EY01

Technical Data

Power supply	Class 2 via bus line, 24V DC. Consumption: 9 mA (at bus voltage)
Inputs	<p>16 channels Time base: quartz precision 500 memory locations in EEPROM Shortest switching interval: 1 second / minute switching accuracy: 1 second Shortest impulse 1 second Time accuracy: ±1 Sec./ Tag or radio controlled Power reserve: Lithium battery ca. 1 1/2 years at 68°F (20°C) Type of Lithium battery: CR 2450 Daily, weekly, yearly and impulse programs as automatic programs Manual overrides - Temporary manual override - Permanent manual override Programming: Via 10-key keyboard or with PC Obelisk software and Obelisk memory card Block formation: Free block formation of week days and channels Automatic Summer / Winter time changeover</p>
Control Elements	<p>One learning button: for switching between normal operating mode and addressing mode 15 soft touch buttons: for setting day of week, hour, minute, time, program entry and 16 manual overrides</p>
Display Elements	<p>One red LED: for monitoring bus voltage and displaying mode, selected with the learning button LC Display: for display of time, day of week, daylight savings mode, holiday program mode, switching status and manual control mode</p>
Connections	Bus line: screwless bus connection block
Physical Specifications	<p>Polymer casing DIN rail mounted device Weight: 1.00 lb (451 g) installation: rapid mounting on DIN EN50022-35 x 7.5 rail</p>
Reliability	99.92% based on 1,000,000 units/10 years of operation under load
Electromagnetic Compatibility	Complies with Part 15 of the FCC rules pursuant to the limits for a Class A digital device
Environmental Specifications	<p>Ambient temperature operating: 23°F – 113°F (-5... +45°C) Ambient temperature non-op.: -13°F – 158°F (-25... +70°C) Relative humidity (non-condensing): 5 % to 93</p>
Listings and Certifications	<p>EIB certified CE Mark Complies with EMC regulations (residential and nonresidential buildings) and low voltage regulations</p>

Typical Circuit

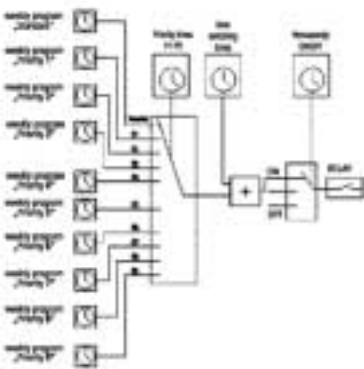

Lighting Control

LCP3000EZ
Lighting Control System

Power Supply Unit N 123 320 mA



Dimension Diagrams

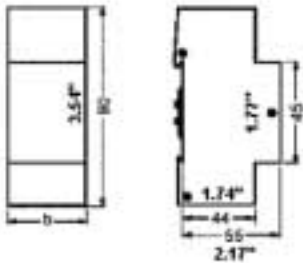

- Dimensions in mm and inches
b = 3 TE
1 Spacer unit (1 SU) = 18 mm (0.71")

Typical Circuit

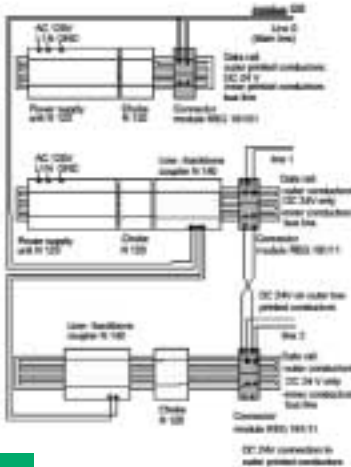

The power supply unit N 123 provides and monitors the necessary Class 2 power for the *instabus EIB* system. At least one power supply unit is required per bus line. Power supply units are mounted on a DIN-rail equipped with a data-rail in a control panel. The power supply unit N 123 must be installed in combination with choke N 120. Choke and power supply unit have to be mounted on the same DIN rail and are connected via the data rail. No more than two power supply units may be used with a single bus line. A second unit (power supply unit and choke) is not required unless the working voltage at a bus device falls short of 21V. The cable length between the two power supply units must be at least 200 m (600'). When more than 30 bus devices are installed in short bus cable distance

(approx. 10 m) (30') (e.g., in control panel boards), the power supply unit N 123 should be situated near these bus devices. The wire length between power supply unit N 123, choke N 120 and any of its bus devices must not exceed 350 m (1000'). The power supply unit N 123 has a voltage and current control and is therefore short-circuit proof. Short power breakdowns are bridged with a buffer interval of at least 100 ms. By connecting two power supply units N 123 in parallel to the *instabus* via the same choke N 120, the tolerable current can be increased from 320 mA to 500 mA (while maintaining the buffer interval). For uninterrupted power, it is suggested to use a separately safeguarded circuit for the power supply unit N 123's power supply line.

Order No.

5WG1 123-1CB01

Technical Data

Input Voltage	Rated voltage 120V AC Frequency 50... 60 Hz Permissible range: 100... 132V AC
Rated Power Consumption	Approx. 24V AC
Output Voltage	Rated voltage 29V DC safety extra low voltage (SELV) Permissible range: 28... 30V DC
Output Current	Rated current 320 mA Short-circuit current: limited to 1.5 A
Backup Interval	On input voltage failure: min. 200 ms at rated current
Control Elements	Slide switch for re-setting the bus devices connected to the line (operation > 10 s)
Display Elements	1 red LED for indicating a shorted-out bus line or device over-load 1 green LED for indicating faultless operation 1 yellow LED for indicating external overvoltage on the busline power supply in reset mode
Connections	Mains connection, screw-less plug-in terminals: AWG #14 solid Cu bus line, pressure contacts on data rail
Physical Specifications	Polymer casing, DIN rail mounted device, width: 5.5 (1SU = 18 mm) Weight: approx. 460 g (28 oz) installation: rapid mounting on DIN EN 50022-35 x 7.5 rail
Electromagnetic Compatibility	Complies with Part 15 of the FCC rules pursuant to the limits for a Class A digital device
Environmental Specifications	Ambient temperature operating: 23°F – 113°F (-5... +45°C) Ambient temperature non-op.: -13°F – 158°F (-25... +70°C) Relative humidity (non-condensing): 5 % to 93%
Listings and Certifications	UL listed (E173 174) UL 916, Open Energy Management Equipment CSA certified (pending) CE marked complies with EMC regulations (residential and non-residential buildings) and low voltage regulations EIB certified

Choke N 120 500 mA



The bus devices' working voltage is transmitted via the same cable as the data telegrams. The choke N 120 protects these data telegrams from becoming terminated on the bus line by the power supply. The choke picks up the working voltage on the two outer printed conductors of the data rail and feeds it to the two inner printed conductors via induction. The working voltage is directly fed to the DIN rail's two outer printed conductors by a power supply unit N 123. Via the incorporated reset-switch (operation > 10 s), the bus

devices are set to their default setting (i.e., the bus devices return to their default setting with the recurring working voltage). This is done by short-circuiting the bus line and switching off the working voltage. The choke resistance is low-ohmic for the direct current of the working voltage. As information is transformed to alternate current for transmission on the *instabus* system, the resistance of the choke N 120 is high-ohmic. Therefore, the working voltage does not significantly affect the information signal.

Dimension Diagrams

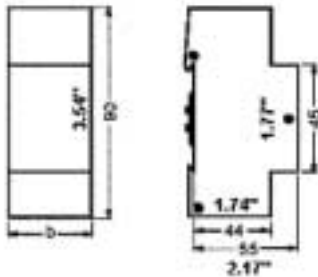

- Dimensions in mm and inches
- b = 3 TE
- 1 Spacer unit (1 SU) = 18 mm (0.71")

Typical Circuit

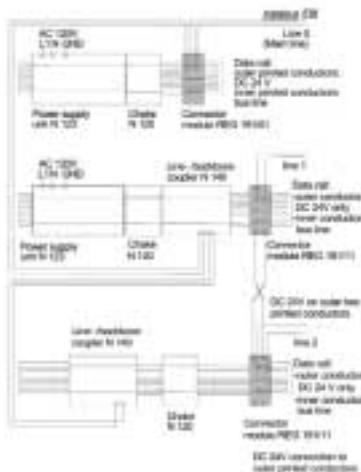

Order No.

5WG1 120-1AB01

Technical Data

Input Voltage	Rated voltage: 29V DC (28... 30V DC) Rated current: 500 mA
Control Elements	Slide switch: for resetting the bus devices connected to the line (operation > 20 s)
Display Elements	One red LED: for indicating when the slide switch is set to reset-position
Connections	Power supply: pressure contacts on data rail (outer printed conductors) Bus line, pressure contacts on data rail (inner printed conductors)
Physical Specifications	Polymer casing N-system DIN rail mounted device, width: 2 SUs (1 SU = 18 mm) Weight: approx. 105 g (4 oz) Installation: rapid mounting on DIN EN 50022-35 x 7.5 rail

Reliability 99.92% based on 1,000,000 units/10 years of operation under load

Electromagnetic Compatibility Complies with Part 15 of the FCC rules pursuant to the limits for a Class A digital device

Environmental Specifications Ambient temperature operating: 23°F – 113°F (-5... +45°C)
Ambient temperature non-op.: -13°F – 158°F (-25... +70°C)
Relative humidity (non-condensing): 5 % to 93

Listings and Certifications
UL listed (E173 174)
 UL 916, Energy Management Equipment Accessory
CSA certified
 (pending)
CE marked
 complies with EMC regulations (residential and non-residential buildings) and low voltage regulations
EIB certified

Lighting Control

LCP3000EZ
Lighting Control System

Line/Backbone Coupler N 140



The line/backbone coupler N 140 establishes a data link between two separate bus lines and galvanically separates these bus lines. Thus, each bus line can operate independently from the

other lines in their local operating scope. There are no differences in hardware between the line and the backbone coupler.

Order No.

5WG1 140-1AB03

Technical Data

Rated Voltage	Bus line: 24V DC (21... 30V DC).
Control Elements	One learning button: for switching between normal operating mode and addressing mode
Display Elements	One red LED: for controlling bus voltage and displaying mode the learning button
Connections	Bus line: pressure contacts on data rail
Physical Specifications	Polymer casing DIN rail mounted device, width: 1 SU (1 SU = 18 mm - 0.71") rapid mounting on DIN EN 50022-35 x 7.5 rail
Reliability	99.92% based on 1,000,000 units/10 years of operation under load
Electromagnetic Compatibility	Complies with Part 15 of the FCC rules pursuant to the limits for a Class A digital device
Environmental Specifications	Ambient temperature operating: 23°F – 113°F (-5... +45°C) Ambient temperature non-op.: -13°F – 158°F (-25... +70°C) Relative humidity (non-condensing): 5 % to 93%
Listings and Certifications	UL listed (E173 174) UL 916, Energy Management Equipment Accessory CSA certification (pending) CE Mark Complies with EMC regulations (residential and nonresidential buildings) and low voltage regulations

Dimension Diagrams

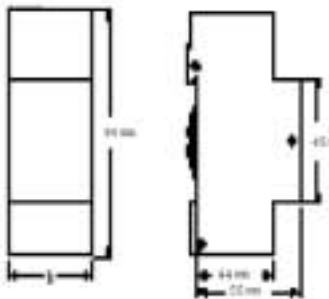

- Dimensions in mm and inches

Interface N 148/04 RS 232



The RS 232 interface N 148/04 is a N-system DIN rail mounted device. The device with integrated bus coupling unit 2.1 is connected to the bus line via the pressure contact system. The N 148/04 interface provides a galvanically separated connection to the bus system via its built-in Sub D 9-pin connector socket. The connection to the PC is made between the 9-pin SUB D socket of the interface N 148/04 and the COM 1 or COM 2 interface of the PC. A DB-9 (male female) serial cable is needed for this connection.

It enables a personal computer (AT compatible PC) to be connected for addressing, configuring, visualising, logging and diagnosis of bus devices. With the N 148/04 interface, it is possible to operate all bus devices in the whole bus system with one of two selectable protocols: the standard protocol and the FT1.2 protocol. The standard protocol is used e.g. by ETS. The FT1.2 protocol is used by various operator software packages and software interfaces.

Dimension Diagrams

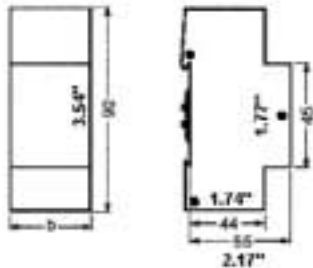

• Dimensions in mm and inches

Typical Cable Circuit



Order No. 5WG1 148-1AB04

Technical Data

Rated Voltage	Bus line: 24V DC (21... 30V DC).
Transmission Rate	9600 bit/s, 19200 bit/s
Control Elements	One learning button: for switching between normal operating mode and addressing mode
Display Elements	One red LED: for controlling bus voltage and displaying mode the learning button
Connections	Bus line: pressure contacts on data rail RS 232 interface: 9-pin Sub D socket length of data cable: max. 15 m (45 ft) Serial connection DB-9 (male female cable available in electronics stores)

Physical Specifications

Polymer casing
DIN rail mounted device, width: 1 SU (1 SU = 18 mm - 0.71")
rapid mounting on DIN EN 50022-35 x 7.5 rail

Electromagnetic Compatibility

Complies with Part 15 of the FCC rules pursuant to the limits for a Class A digital device

Environmental Specifications

Ambient temperature operating: 23°F – 113°F (-5... +45°C)
Ambient temperature non-op.: -13°F – 158°F (-25... +70°C)
Relative humidity (non-condensing): 5 % to 93%

Listings and Certifications

UL listed (E173 174)
UL 916, Energy Management Equipment Accessory
CSA certified (pending)
CE Mark
Complies with EMC regulations (residential and nonresidential buildings) and low voltage regulations
EIB certified

Lighting Control

LCP3000EZ
Lighting Control System

Connector REG 191/01 2 fold



The connector module REG 191/01 provide the connection between the data rails within a panel or between panels throughout the building. The connection to the data rail is established via pressure contacts (both printed conductors conductor strips (Data Rail) snap onto the

DIN rail). The bus cables are connected via two screwless bus connector blocks 193. Up to four bus cables may be connected per bus connector block 193. The DIN rail mounted device is of compact design to allow mounting beneath control panel covers.

Order No.

5WG1 191-5AB01

Technical Data

Connections

For both bus connections Contact pins

For the bus Pressure contacts

Physical

Specifications

Polymer casing
N-system DIN rail mounted device. Width is 1 SU (1 SU = 18 mm).
Weight: approx 4.5 gr (2 oz)
Installation: rapid mounting on DIN 3.5 X 7.5 DIN rail

Environmental

Specifications

Ambient temperature operating: 23°F – 113°F (-5... +45°C)
Ambient temperature non-op.: -13°F – 158°F (-25... +70°C)
Relative humidity (non-condensing): 5 % to 93%

Accessories

Bus connection block 193

Dimension Diagrams

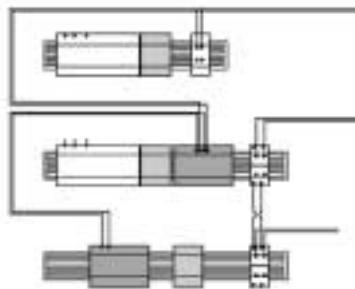
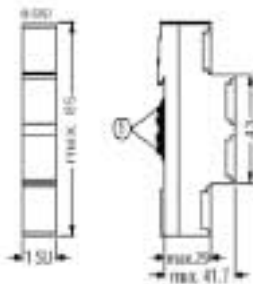

Accessories

Cover Strip 192

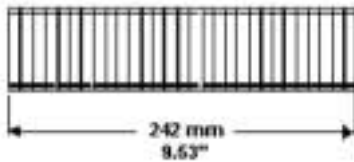

- Dimensions in mm and inches

Bus Connection Block 193 2-poles, 4 connection points

The bus connection block 193 is used for connecting the bus line to the bus devices but can also be used in branching boxes for connecting bus cables.



Extra Low Voltage Connection Block 194 2-poles, 4 connection points

This is used for connecting the white and yellow wire of the bus line and for plugging into devices to link up with the outer printed conductors of the data rail.

Data Rail 190

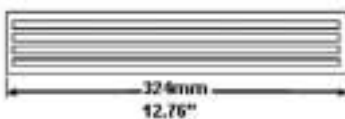

- Dimensions in mm and inches



Cover Strip 192

The cover strip 192 is snapped onto unoccupied sections of DIN rails with fitted

data buses in order to maintain conditions for safety extra-low voltage SELV.

Order No.

5WG1 192-8AA01

Technical Data

Length	Class 2 via bus line, 24V DC. Consumption: 8 mA (at bus voltage)
Mounting	on DIN rail 35 x 7.5
Weight	approx. 20 g (1 oz)

Bus Connection Block 193 (2-poles, 4 connection points)

The bus connection block 193 is used for connecting the bus line to the bus devices

when the connection is not possible through a data rail.

Order No.

5WG1 193-8AB01

Technical Data

Structure	two latched parts "+" (red) and "-" (black)
Plug-in Connections	2 x 4, AWG #24-18 solid Cu (Screwless)
Mounting	is plugged into the bus device or used in branching boxes
Weight	approx. 5 g (.2 oz)

Extra Low Voltage Connection Block 194 (2-poles, 4 connection points)

This is used for connecting the 24V DC power to bus devices when the connection is not possible through a data rail. (24V DC

on the outer printed conductors of the data rail).

Order No.

5WG1 194-8AB01

Technical Data

Structure	two latched parts "+" (red) and "-" (black)
Plug-in Connections	2 x 4, AWG #24-18 solid Cu (Screwless)
Mounting	is plugged into the bus device or used in branching boxes
Weight	approx. 5 g (.2 oz)

Data Rail 190

The data rail 190 is glued into the DIN rail, and it connects devices together via pressure contacts in the instabus devices (in N-system dimensions). The data rail has

four printed conductors whereby the middle pair conducts the bus voltage and the outer pair connects the power supply to the choke.

Order No.

5WG1 190-8AB31 Length 324mm

Technical Data

Structure	Self-adhesive conductor plate in anticorrosive design, secure contact pressure
Length	277 mm for max. 16 SU = 10.90"
Mounting	is glued into DIN rail 35 x 7.5
Weight	approx. 24 g (1 oz)

Lighting Control

LCP3000EZ
Lighting Control System

Dual Sensor AP 254



The Dual Sensor AP 254 provides ambient light level and outdoor temperature values. These values can be sent onto the bus.

The Dual Sensor AP 254 is suitable for multi-staged lighting controls.

This device controls load switches based on threshold settings for ambient light level.

Order No.

5WG1 254-3EY01

Technical Data

Power supply	Class 2 via bus line, 24V DC Operating voltage: 21V DC - 30V DC
Measuring range	Light level: 0.09.... 9300 Foot-candle (1... 100,000 Lux), ± 5 Lux or ± 20 Lux Temperature: -13°F.... 131°F (-25... 55°C), ± 1 or ± 5% The higher value of tolerance is applicable.
Control Elements	One learning button: for switching between normal operating mode and addressing mode
Display Elements	One red LED: for monitoring bus voltage and displaying mode, selected with the learning button
Connections	Bus line, screwless bus connection block
Physical Specifications	Housing: Polymer
Reliability	99.92% based on 1,000,000 units/10 years of operation under load
Electromagnetic Compatibility	Complies with Part 15 of the FCC rules pursuant to the limits for a Class A digital device
Environmental Specifications	Ambient temperature operating: -13°F – 113°F (-25... +55°C) Ambient temperature non-op.: -13°F – 158°F (-25... +70°C) Relative humidity (non-condensing): 5 % to 93
Listings and Certifications	EIB certified Complies with EMC regulations (residential and nonresidential buildings)

Dimension Diagrams

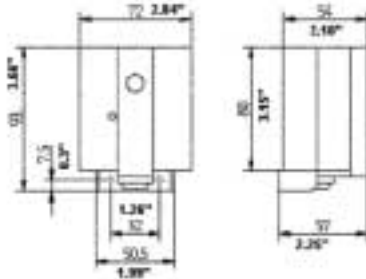

- Dimensions in mm and inches

Connection to Bus Line



Bus Coupling Unit UP 114/02



The bus coupling unit (BCU) UP 114 enables application units (AUs) such as motion sensor (UP 255) to be connected to the bus line via the physical external interface (PEI). It contains a BCU and is required for extensive application programs. The telegrams received via the bus line are processed by the bus coupling unit (BCU) and passed on to the application unit. In the opposite direction, signals coming from the AU are converted into telegrams and transmitted. The bus

coupling unit UP 114 is directly connected to the bus line. It constantly monitors the bus and thus continuously is aware of whether the line is clear for sending or busy with other telegrams. Upon appropriate events the BCU will send immediately provided the bus is not busy. Otherwise the sending request will be postponed until the line is disengaged. The connection to the bus line is established via screwless plug-in terminals.

Dimension Diagrams

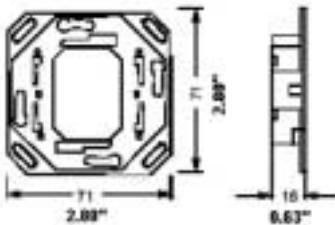

- Dimensions in mm and inches

Order No.

5WG1 114-2AB02

Technical Data

Power supply	Class 2 via bus line, 24V DC Operating voltage: 21V DC - 30V DC
Control Elements	One learning button: for switching between normal operating mode and addressing mode
Display Elements	1 red LED: for monitoring bus voltage and displaying mode, selected with the learning button
Connections	10-pin socket (PEI): to connect with an application unit (motion sensor) Bus line, screwless bus connection block
Physical Specifications	Housing: plastic
Reliability	99.92% based on 1,000,000 units/10 years of operation under load
Electromagnetic Compatibility	Complies with Part 15 of the FCC rules pursuant to the limits for a Class A digital device
Environmental Specifications	Ambient temperature operating: 23°F – 113°F (-5... +45°C) Ambient temperature non-op.: -13°F – 158°F (-25... +70°C) Relative humidity (non-condensing): 5% to 93%
Listings and Certifications	CE norm Complies with EMC regulations (residential and nonresidential buildings) and low voltage regulations

Typical Circuit

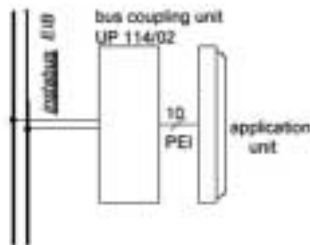

Lighting Control

LCP3000EZ
Lighting Control System

Motion Detector UP 255



The motion detector UP 255 is a proximity sensor which reacts to movements of people, animals or other moving objects. If a motion is detected, the corresponding telegrams are sent on the bus. It is used for example to detect people moving in its monitoring area. Using an appropriate application program, it gives switching commands via the flush-mounted bus coupling unit to actuators such as binary outputs to switch groups of luminaries or

to signaling units. It must be installed on the flush-mounted bus coupling unit (UP 114). It is only operational when used together with the bus coupling unit and the corresponding application program i.e. the motion detector UP 255 with flush-mounted bus coupling unit (UP 114) consists of the device (hardware) and the application program (software). The device is for permanent interior installations, in dry rooms.

Order No.

5WG1 255-2AB11

Technical Data

Power supply	Via the bus coupling unit.
Properties	Light sensor: adjustable in steps from 0.9 to 93 foot-candles (1 to 1000 Lux) (daylight mode to night mode). Horizontal detection angle: 180 degrees on two levels (can be reduced to 90° on the left or right using a detachable masking plate) Lateral range: approx. 20 ft (6 m) each side. Optical system: Fresnel lens (2 levels with 18 segments)
Operating Elements	Potentiometer for step-less adjustment of the range between 100% and 20%.
Connections	10-pole plug connector (PEI): for connection to the bus coupling unit
Physical Specifications	Housing: Plastic Dimensions (L x W x D): 65 x 65 x 30 mm (2.56" x 2.56" x 1.18") Weight: approx. 45 g (0.095 lb) Fire load: approx. 750 kJ ± 10 % Mounting: clipped onto bus coupling unit Mounting height: 3.6 to 7.2 ft (1.10 m to 2.20 m)
Reliability	99.92% based on 1,000,000 units/10 years of operation under load
Electromagnetic Compatibility	Complies with Part 15 of the FCC rules pursuant to the limits for a Class A digital device
Environmental Specifications	Ambient temperature operating: 23°F – 113°F (-5... +45°C) Ambient temperature non-op.: -13°F – 158°F (-25... +70°C) Relative humidity (non-condensing): 5 % to 93
Listings and Certifications	EIB certified CE Mark Complies with EMC regulations (residential and nonresidential buildings) and low voltage regulations

Dimension Diagrams

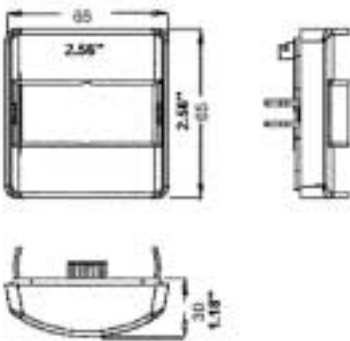

- Dimensions in mm and inches

Switch Interface UP 220



The switch interface UP 220 is a binary input device for installation in a standard junction or wall switch box. 4 inputs are available for potential-free switching/keying contacts. The scanning voltage for these contacts is provided by the switch interface UP 220 (no additional power supply required). Up to four

switches may be connected to a switch interface UP 220. The connection to the switch interface UP 220 is accomplished via a plug-in eight-core set of lines (included). The length of the cables that connect the switches to the switch interface UP 220 must not exceed 5 m (15'!

Order No.

5WG1 220-2CB01

Dimension Diagrams

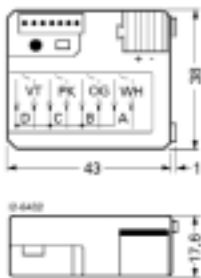

- Dimensions in mm

Technical Data

Power supply	Via the bus line
Number of inputs	4 for momentary or maintained contact switches/push buttons
Scanning voltage	24V DC (supplied by the wall switch interface)
Connections: switches/ push buttons	Eight wires twisted together in pairs with the pushbutton interface permanently connected, length approx. 150 mm, may not be extended
bus line, bus connection block screwless	Use bus connector 193, see system accessories
Protection class	III
Mounting	Fitted in standard wall switch and junction boxes

Typical Circuit



Lighting Control

LCP3000EZ
Lighting Control System

Touch Panel Vision UP 588



The touch panel vision UP 588 is a multifunctional display/control unit. The basis of the device is an LC display with a resolution of 320 x 240 pixels and an integrated, resistive matrix with 6 x 10 fields. The display has backlighting available (green), which is activated during operation and can be switched off automatically after an adjustable period. In connection with the associated

application program, the display unit can be used for the following functions:

- To display and operation of up to 70 standard functions on 7 display pages,
- To display an alarm page with 4 alarm signals and 2 text messages,
- To execute time-controlled tasks.

Design, aluminum frame (Cat # 5WG1 588-8AB01) is required for the touch panel.

Order No.

5WG1 588-2AB_1

Technical Data

Dimension Diagrams

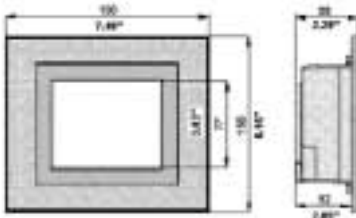

- Dimensions in mm and inches

Power supply	Bus voltage: via the bus line External power supply 230V AC or 120V AC \pm 15%, 50/60 Hz
Operating Elements	One learning button: for switching between normal operating mode and addressing mode Resistive matrix with 6 x 10 fields (touch-sensitive display)
Display Elements	Red programming LED: for displaying normal/addressing mode 320 x 240 pixel display with graphic capability and green backlighting
Connections	Bus line: EIB bus terminal, screw-less connection
Physical Specifications	Housing: plastic Mounting depth in flush-type box: 2.05" (52 mm) Installation: screwed into the flush-type box Dimensions of flush-type box (W X H X D): 6.3" X 5.12" X 2.76" (160 x 130 x 70 mm), included with supply. Weight: approx. 0.77 Lb (350 g)
Reliability	99.92% based on 1,000,000 units/10 years of operation
Electromagnetic	Complies with Part 15 of the FCC rules pursuant to the limits for a Class A digital device
Environmental Specifications	Ambient temperature operating: 23°F – 113°F (-5... +45°C) Ambient temperature non-op.: -13°F – 158°F (-25... +70°C) Relative humidity (non-condensing): 5% to 93
Listings and Certifications	UL listed (E173 174) UL 916, Energy Management Equipment Accessory) and low voltage regulations

Ethernet Interface AP 146



The interface for Ethernet-UDP/IP AP 146 is a surface mounted device. This interface connects an *instabus* system to a PC or other Internet Protocol (IP) enabled device via the Intranet. Using the Internet Protocol the interface offers remote configuration and operation of devices over a LAN or Intranet connection. The interface also connects to a time server on the Intranet to provide accurate date and time to the devices. The IP address of the interface is assigned to the device via

special software (ETS), or automatically is assigned by a BootP server on the IP network. Assigning the IP address from a BootP server allows for changes to the IP address without changing the setup of the device itself. The fixed MAC address required to configure the BootP server is printed on the device. With the ETS Software the application program is selected, its parameters and addresses are assigned appropriately and downloaded to the Ethernet-UDP/IP interface AP 146.

Order No.

5WG1 146-1CB01

Dimension Diagrams

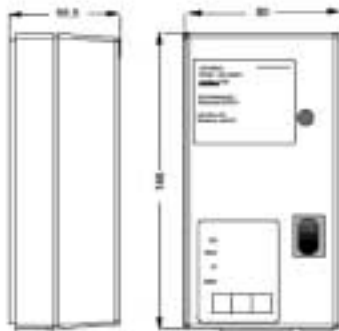

B = 80 mm - 3.15 inches
H = 55.5 mm - 2.19 inches
L = 146 mm - 5.75 inches

Typical Operation

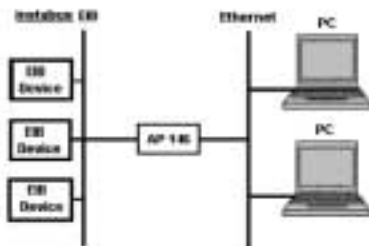

Technical Data

Power supply	Class 2 via bus line and separate 6V= Class 2 power supply.
Control Elements	One learning button: for switching between normal operating mode and addressing mode; 1 red LED for controlling bus voltage and displaying mode, selected by the learning button
Display Elements	One red LED: for monitoring bus voltage and displaying mode, selected with the learning button Four red LEDs: indicating the communication status M – Device can access Ethernet communication LK – Ethernet connection is alive Rx – receiving Ethernet-IP data Tx – transmitting Ethernet-IP data
Connections	Power supply: - Socket for Class 2 power supply 6-12V DC (power supply unit with primary 100-240V AC, secondary 6V DC, 2.1 Amp) Ethernet IP communication: - RJ45 socket Bus line: - <i>instabus</i> SMS EIB-Socket 2-pole
Physical Specifications	Polymer casing Surface mounted device Weight: approx. 225 g (0.496 lbs)
Communications	<ul style="list-style-type: none"> • Ethernet - 10Mb/s - MAC address printed on device • Internet Protocol - UDP/IP - BootP
Electromagnetic Compatibility	Complies with Part 15 of the FCC rules pursuant to the limits for a Class A digital device
Environmental Specifications	Ambient temperature operating: 23°F – 113°F (-5... +45°C) Ambient temperature non-op.: -13°F – 158°F (-25... +70°C) Relative humidity (non-condensing): 5 % to 93
Listings and Certifications	CE marked complies with EMC regulations (residential and nonresidential buildings) and low voltage regulations EIB certified



Siemens Energy & Automation, Inc.

Power Distribution Solutions
3333 Old Milton Parkway
Alpharetta, GA 30005

For more information, call **1-800-427-2256**
or visit **www.sea.siemens.com**

© 2004 Siemens Energy & Automation, Inc. All Rights Reserved

Siemens is a registered trademark of Siemens AG. Product names mentioned may be trademarks or registered trademarks of their respective companies. Specifications are subject to change without notice.