

RF converter

WTX660-E05060



The WTX660.. RF converter receives and processes data from heat cost allocators, heat and water meters within a M-bus radio system.

- Storage for up to 500 metering devices
- Repeater on the mesh system for up to 2,000 additional wireless devices
- Coverage of distances up to 500 meters outdoors and 40 meters in buildings
- Supports devices using AES128 encryption
- RF converter with mains power AC 230 V
- Optimum location function
- LED to indicate signal strength

Use

The RF converter WTX660-E05060 is a component of the M-bus radio network.

The RF converter receives the radio telegrams from up to 500 consumer metering devices and then sends the data to the web server. The web server simultaneously serves as a repeater for other wireless devices.

Functions

Communications

Up to 23 RF converters can communicate with one another on a mesh network. Up to 2,500 wireless devices can be managed and read out on each network. Communications between the RF converters and wireless devices takes place over the wireless M-bus protocol.

The RF converter receives the data from one or more wireless devices within a radio system as per EN13757-4. It saves the consumption data from the devices in its environment and forwards this data simultaneously with data from other RF converters to the web server (repeater functionality for the other RF converters).

A minimum of one M-bus web server and one RF converter is required to read out wireless devices.

Optimum location

You can power the RF converter over the USB connection using an external battery to help find the optimum location. The RF converter remains mobile during the scan and can be moved to the location with the best signal reception. The blue LED flashes during the scan and indicates the status. The blue LED stops flashing once a connection is found.

The four green LEDs indicate the signal strength. All four LEDs are on for a strong signal.

Configuration

The ACT531 readout software configures the Mesh-ID and Channel-ID. A USB cable with a mini USB-B connection on the RF converter and the PC's USB interface is used to connect the RF converter and PC.

Design

The RF converter essentially consists of three housing components: The base for wall mounting, the removable cover and the cover for the cable compartment.

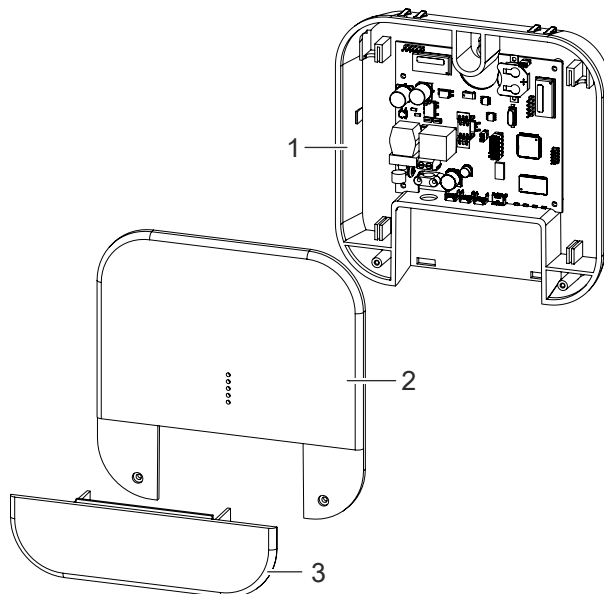

- | | | | |
|---|---------------------------------|---|-----------------|
| 1 | Base for wall mounting | 2 | Removable cover |
| 3 | Cover for the cable compartment | | |

Removable cover version

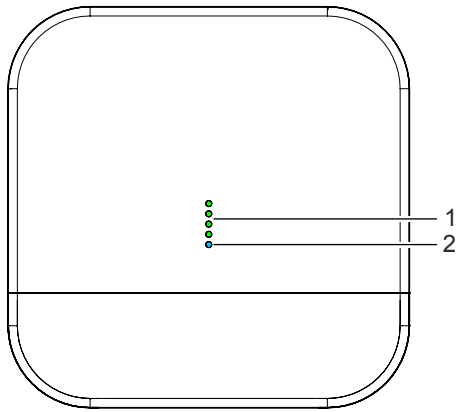

- 1 Green LEDs indicate the signal strength (active only in scan mode) 2 Blue LED for status indication

Cover version

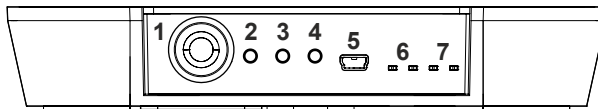

- 1 Mains power connection (AC 100..240 V) 2 S1 - Local settings
 3 S2 - Local settings 4 Reset button
 5 USB connection 6 LED mesh network
 7 LED wireless M-bus network

Type summary

Order information

Description	Order number	Type
RF converter	S55563-F149	WTX660-E05060

Delivery

Mounting instructions are included with the RF converter in various languages as well as mounting materials.

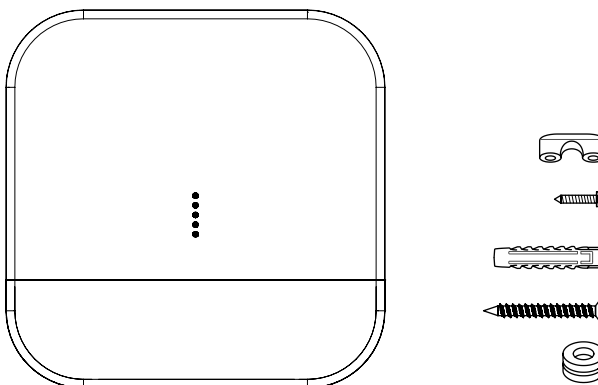

Equipment combinations

The RF converter WTX660-E05060 is compatible with the following products:

Type	Order number	Designation
WTV676-HB6035	S55563-F150	M-bus web server
ACT531	JXF:ACT531	Readout software > version 2.0

Product documentation

Topic	Title	Document ID
Mounting Instructions	RF converter WTX660-E05060	A6V11135905
User's guide	M-bus readout software ACT531	A6V10844345
User's guide	M-bus web server WTV676-HB6035 M-bus level converter WTV531-GA5060 RF converter WTX660-E05060	A6V11157985

Product inserts

Mounting instructions are included with the RF converter in the following languages:

German, English, French, Dutch, Italian, Finnish, Spanish, Norwegian, Polish, Czech, Slovakian, Hungarian, Greek, Croatian, Slovenia, Lithuanian, Bulgarian, Turkish.

Related documents such as environmental declarations, CE declarations, etc., can be downloaded at the following Internet address:

<http://siemens.com/bt/download>

Notes

Mounting



- Specialist electrical engineering knowledge is required for installation.
- Only an expert is permitted to carry out installation work.

Incorrect installation can take safety devices out of operation unbeknown to a layperson.



⚠ WARNING

Electricity on the lines

Risk of injury from electric shock

- Strain relief required on mains connection

The RF converter is wall mounted. Additional information on mounting the RF converter is available in document A6V11135905. See Section Product documentation [→ 4].

Commissioning

The ACT531 readout software is required to upload firmware updates or to configure the network. Additional information on the ACT531 readout software is available in document A6V10844345. See Section Product documentation [→ 4].

Disposal

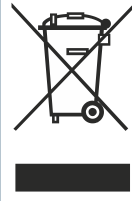

The device is considered an electronics device for disposal in terms of European Directive 2012/19/EU and may not be disposed of as domestic garbage.

- Dispose of the device through channels provided for this purpose.
- Comply with all local and currently applicable laws and regulations.
- Dispose of empty batteries in designated collection points.

Warranty

Technical data on specific applications are valid only together with Siemens products listed under "Equipment combinations". Siemens rejects any and all warranties in the event that third-party products are used.

Technical data

Power supply	
Operating voltage	AC 100...240 V
AC frequency	50/60 Hz
Maximum power consumption	4.5 W
Battery backup of real-time clock Lithium type CR2032 (can be replaced on the plant)	Battery operation: A total of 10 years Unused: 10 years

Display	
Display	LED front and in the housing

Interfaces	
Radio AMR (Mesh)	
Frequency	868 MHz
Max. distance between the RF converters	Outdoors: 500 m In buildings: 40 m
M-bus interface	
Reference standard	EN13757-4 (Physical Layer), EN13757-3 (Application Layer)
Frequency	868 MHz
Max. number of M-bus wireless devices per RF converter	500
M-bus operating modes	C1, T1, S1
USB connection	USB2.0 A / Mini-USB B 5 pin

Ambient conditions	
Operating temperature	-20..+55 °C
Storage temperature	-25..+85 °C
Degree of protection	IP40 per EN60529
Protection class	II per EN 62368-1

Standards, directives and approvals	
Product standard	EN 62368-1 Information Technology Equipment - Safety - Part 1
Electromagnetic compatibility	For residential, commercial, and industrial environments
EU conformity (CE)	A5W00034204 *)
Environmental compatibility	A5W00035028 *)

*) Documents can be downloaded at <http://siemens.com/bt/download>.

External features	
Housing (material)	PC+ABS
Housing (color)	RAL 9016
Dimensions (L x W x T)	160 x 160 x 35

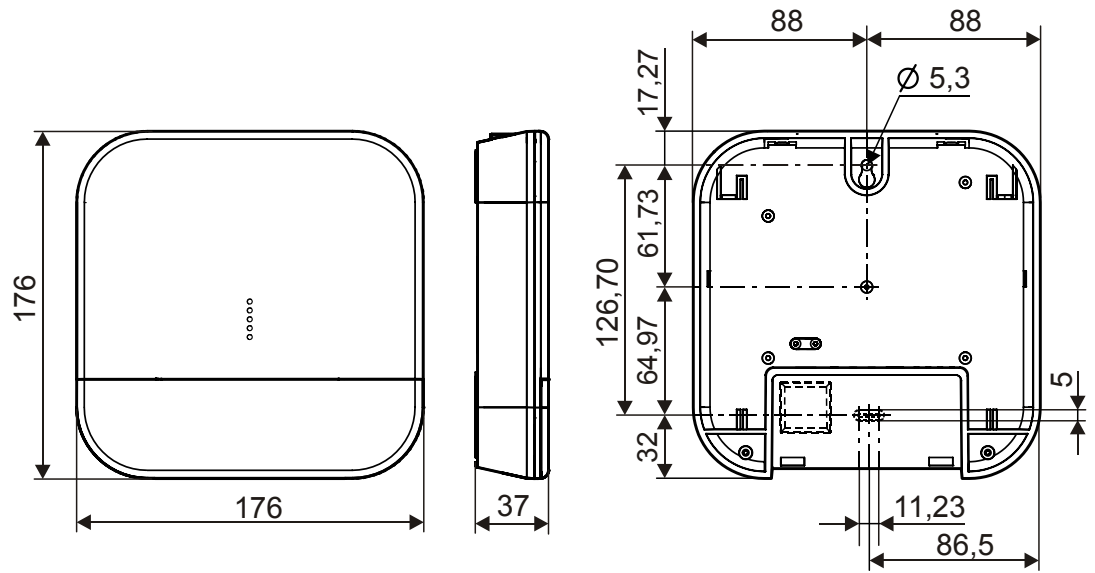

Dimensions in mm

Issued by
Siemens Switzerland Ltd
Building Technologies Division
International Headquarters
Gubelstrasse 22
CH-6301 Zug
Tel. +41 41-724 24 24
www.siemens.com/buildingtechnologies

© Siemens Switzerland Ltd, 2017
Technical specifications and availability subject to change without notice.