

VVF42..C VVF42..KC VXF42..C

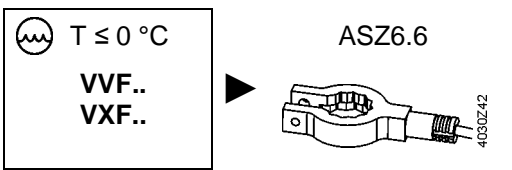

en Notes on mounting	zh-cn 安装说明	zh-tw 安裝說明
<ul style="list-style-type: none"> Only qualified staff may mount, commission and service the valves. Integrate without voltage applied. Do not use valve as fixing point. Remove dirt, welding beads etc. from valves and pipes. Plan for dirt traps. Do not insulate the actuator bracket, as air circulation must be ensured! <p>Installation: Install valve and fit actuator. Open shut-off valves only after actuator is properly fitted.</p> <p>Fill plant: Fill plant only if valves are fully open.</p> <p>Removal: Close shutoff valves. Disassemble actuator from valve only after the pressure in the pipework has been fully reduced.</p> <p>⚠ Do not touch the hot parts without prior protective measures to avoid burns!</p>	<ul style="list-style-type: none"> 只有专业技术人员可以安装、调试、维护阀门。 在无电压工况下安装阀门。 勿用阀门作为固定装置。 清除阀门和管道中的泥土、焊渣等污垢。 管道内设计过滤器。 不要将执行器支架进行保温，以确保其外部空气循环。 <p>安装: 安装阀门后将执行器安装在阀门上。确定正确安装后才可以将阀门开启。</p> <p>注水: 阀门完全开启状态下才可以注水。</p> <p>拆除: 关上阀门。当阀门及管路中的压力完全下降后才可将执行器从阀门上移除。</p> <p>⚠ 如果未预先采取保护措施，禁止触摸加热部件，以防止烫伤！</p>	<ul style="list-style-type: none"> 只有專業技術人員可以安裝、調試、維護閥門。 在無電壓工況下安裝閥門。 勿用閥門作為固定裝置。 清除閥門和管道中的泥土、鋸渣等污垢。 管道內設計過濾器。 不要將執行器支架進行保溫，以確保其外部空氣循環。 <p>安裝: 安裝閥門後將執行器安裝在閥門上。確定正確安裝後才可以將閥門開啟。</p> <p>注水: 閥門完全開啟狀態下才可以注水。</p> <p>拆除: 關上閥門。當閥門及管路中的壓力完全下降後才可將執行器從閥門上移除。</p> <p>⚠ 如果未預先採取保護措施，禁止觸摸加熱部件，以防止燙傷！</p>

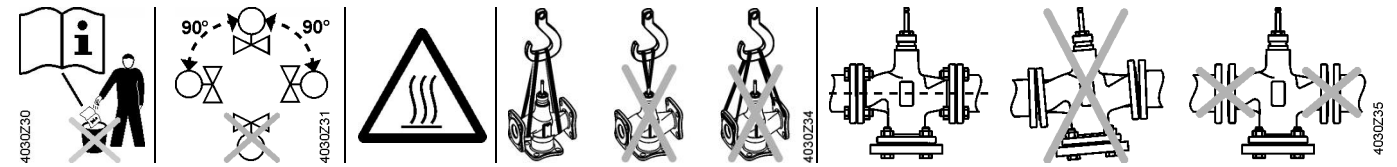

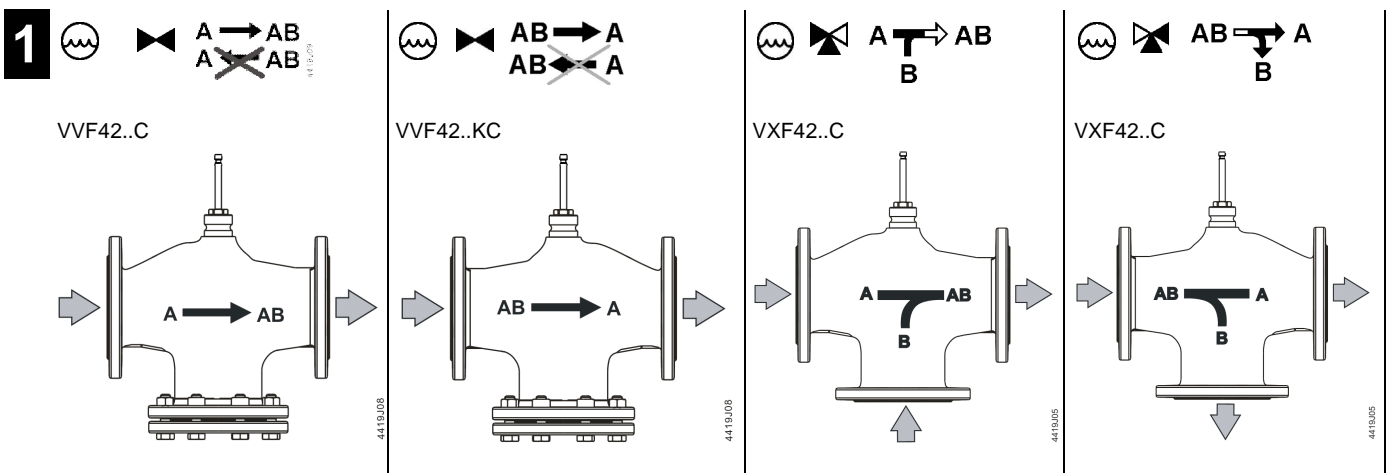
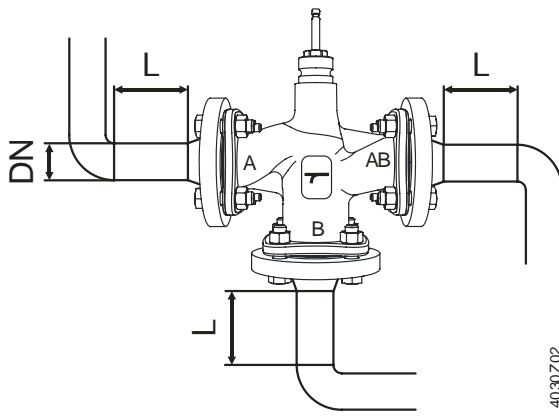

$L \geq 0.4 \text{ m} \dots \geq 10 \times \text{DN}$

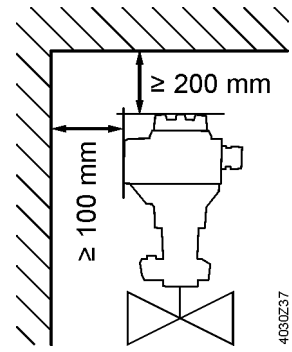

2

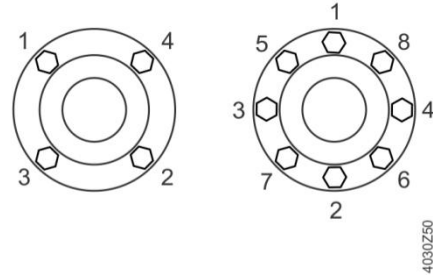
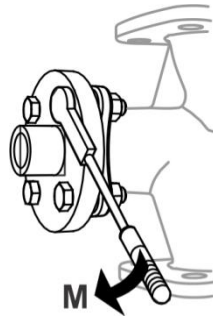
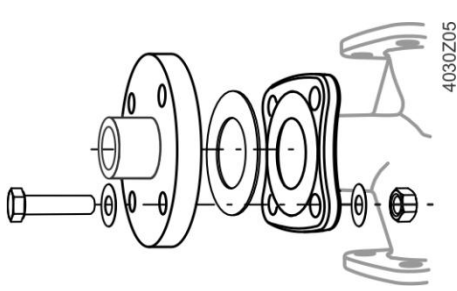

	M_{\max} [Nm]								
DN	25	32	40	50	65	80	100	125	150
PN 16	40	70	70	70	70	70	120	120	210

en

1. Clean flanges
2. Insert gasket between flanges
3. Insert screws, washers and nuts, tighten by hand
4. Tighten screws crosswise in three steps as per the order indicated. Step 1: 25% M, step 2: 50% M, step 3: 100% M. M = max. tightening torque
5. Tighten up with tightening torque M after operating temperature is reached

zh-cn

1. 清洁法兰
2. 法兰中插入垫圈
3. 插入螺钉、垫圈、螺母，手动拧紧
4. 按照如下步骤顺时针拧紧螺钉：第一步，25% M，第二步，50% M，第三步，100% M。M = 最大拧紧力矩
5. 到达工作温度后，按照拧紧力矩拧紧螺钉。

zh-tw

1. 清潔法蘭
2. 法蘭間插入墊圈
3. 插入螺釘、墊圈、螺母，手動擰緊
4. 按照如下步驟順時針擰緊螺釘：第一步，25% M；第二步，50% M，第三步，100% M。M = 最大擰緊力矩
5. 到達工作溫度後，按照擰緊力矩擰緊螺釘。