

Fan coil unit with variable fan, 6-way heating/cooling coil (4 pipe) on analog output DXR2.E09-101A

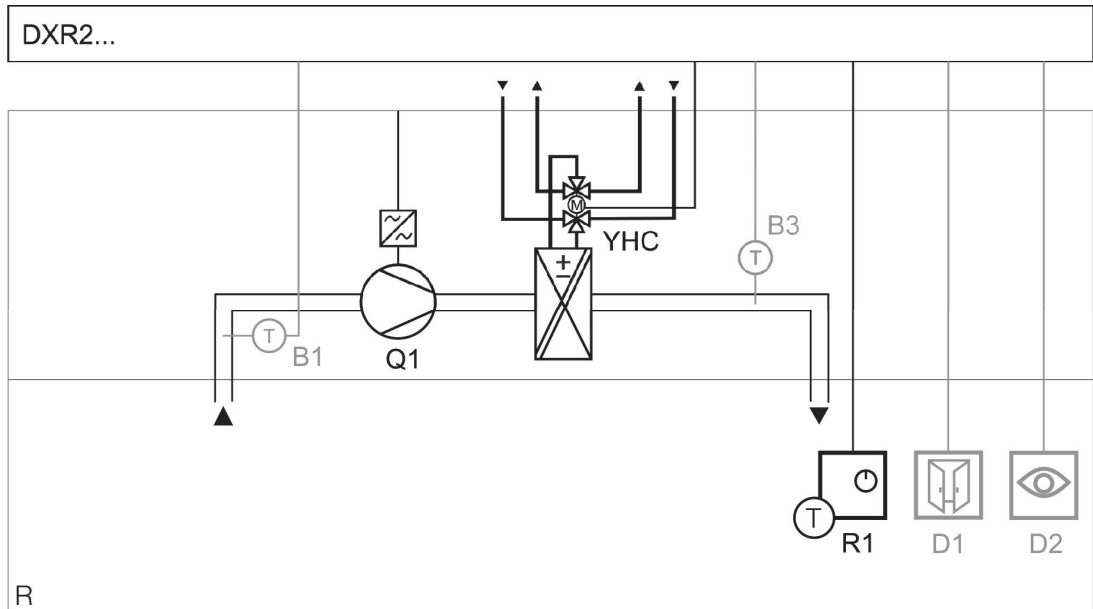

- Heating with LTHW and cooling with CHW changeover
- Modulating control of heating/cooling coil 6-way valve (4 pipe) on analog output
- Automatic or manual variable fan speed control DC 0...10 V
- Room temperature and fan speed operation via KNX PL-Link room operator unit with temperature measurement

Plant diagram



DXR2...	Room automation station	Q1	Variable speed fan
B1	Extract air temperature sensor	R	Room
B3	Supply air temperature sensor	R1	Room operator unit with temperature sensor
D1	Window contact	YHC	Heating/cooling coil valve
D2	Presence detector		

Function diagrams

6-way valve

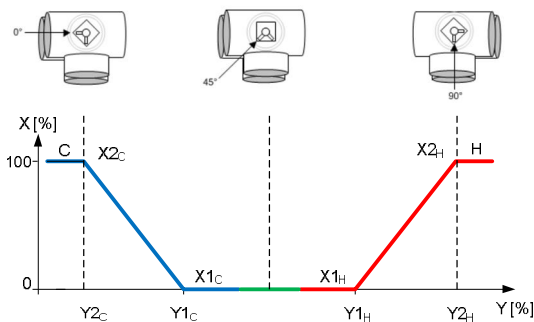

C	Cooling sequence
H	Heating sequence
Q	Fan output signal
SpC	Effective cooling setpoint
SpH	Effective heating setpoint
TR	Room temperature
X	Valve opening
X1 <sub>C</sub>	Cooling coil valve position for value X1
X1 <sub>H</sub>	Heating coil valve position for value X1

DC 0...10 V fan

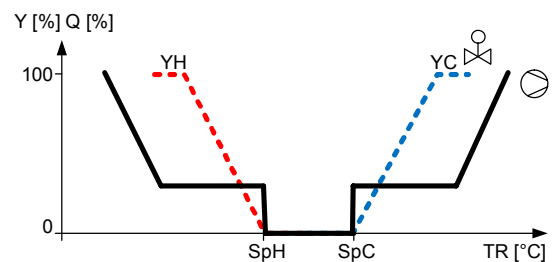

X2 <sub>C</sub>	Cooling coil valve position for value X2
X2 <sub>H</sub>	Heating coil valve position for value X2
Y	Valve output signal
Y1 <sub>C</sub>	Cooling coil valve position for value Y1
Y1 <sub>H</sub>	Heating coil valve position for value Y1
Y2 <sub>C</sub>	Cooling coil valve position for value Y2
Y2 <sub>H</sub>	Heating coil valve position for value Y2
YC	Cooling valve
YH	Heating valve

## Fan coil unit with variable fan, 6-way heating/cooling coil (4 pipe) on analog output DXR2.E09-101A

### Description of functions

#### Basic functions

- PID control for heating and cooling.
- The 4 pipe system provides hot and chilled water for the heating coil and the cooling coil.
- 6 way valve 0...10 V controlled by analog output for heating and cooling.
- The fan is controlled manual on the room operator unit or automatic with variable speed.
- The temperature is measured in the room operator unit.
- The application allows customers to adjust the room temperature setpoints via the room operator unit.
- The operating modes are Comfort, Pre-Comfort, Economy and Protection.
- Change of operating mode via room unit, presence detector, window contact or central command.
- The air flow for heating and cooling is operated in sequence to the valves. Parallel operation can be configured.

#### Auxiliary functions

- Green Leaf (RoomOptiControl) function.
- Multisegment use of DXR2 automation stations with fan coil unit application.
- Standard hot and cold water supply chain control.
- The application allows for control via centralized commands (e.g. scheduler program for room operating mode).
- Central optimum start control provides best room comfort at the start of occupancy.
- Central operation or reset of setpoints, timed valve kick function or outside temperature dependent heating limit.
- Central override functions for valves.
- Seasonal compensation of room temperature setpoints.

#### Options

- Optimal energy efficiency by including the option for room/supply air cascade control, presence detector or window contact.
- Optional system alarms displayed on the management station notify building operators of possible faults.
- Optional trends can be activated for room sensors.

#### Variants

- The room temperature can be measured by:
  - KNX PL-Link wall-mount sensor
  - KNX PL-Link flush-mount room operator unit
  - KNX PL-Link flush-mount sensors
  - Analog extract air temperature sensor
- Presence can be detected by KNX PL-Link sensor or binary sensor.

Siemens devices	Legend	Type of unit	Data sheet	Product No.	Qty.
	DXR2...	Compact room automation station, BACnet/IP, 230 V, flat housing, 1 DI, 2 UI, 3 DO relays, 3 AO 0...10 V	N9204	DXR2.E09-101A	1
	R1	KNX PL-Link room operator unit with temperature sensor, segmented backlit display, touchkeys	N1602	QMX3.P34	1
	YHC	6-way valve	A6V10564480	VWG41.20..	1
		Electromotive actuator, AC 24 V, DC 0...10 V	N4657	GDB161.9E	1

Optional <sup>1)</sup>	Legend	Type of unit	Data sheet	Product No.	Qty.
	B1	Cable temperature sensor PVC 2 m, LG-Ni1000	N1831	QAP22	1
	B3	Cable temperature sensor PVC 2 m, LG-Ni1000	N1831	QAP22	1
	D1	Door/window contact, white	<sup>2)</sup>	S 290/11	<sup>3)</sup>
	D2	KNX PL-Link presence detector with brightness sensor	<sup>2)</sup>	UP 258D12	1 - 4

<sup>1)</sup> Can be combined according to available on-board I/Os on controller.

<sup>2)</sup> Further documents on [www.siemens.com/gamma-td](http://www.siemens.com/gamma-td).

<sup>3)</sup> Type of operation (NO or NC). Multiple devices of the same type can be connected.

Fan coil unit with variable fan, 6-way heating/cooling coil (4 pipe) on analog output DXR2.E09-101A

Variants	Legend	Type of unit	Data sheet	Product No.	Qty.
R1 <sub>a</sub>		KNX PL-Link wall-mount room sensor for temperature	N1602	QMX3.P30	1
R1 <sub>b</sub>		KNX PL-Link flush-mount room operator unit	N1601	QMX3.P36	1
R1 <sub>c</sub>		KNX PL-Link flush-mount room sensors	N1411	AQR253... AQR257...	1

Connection diagram

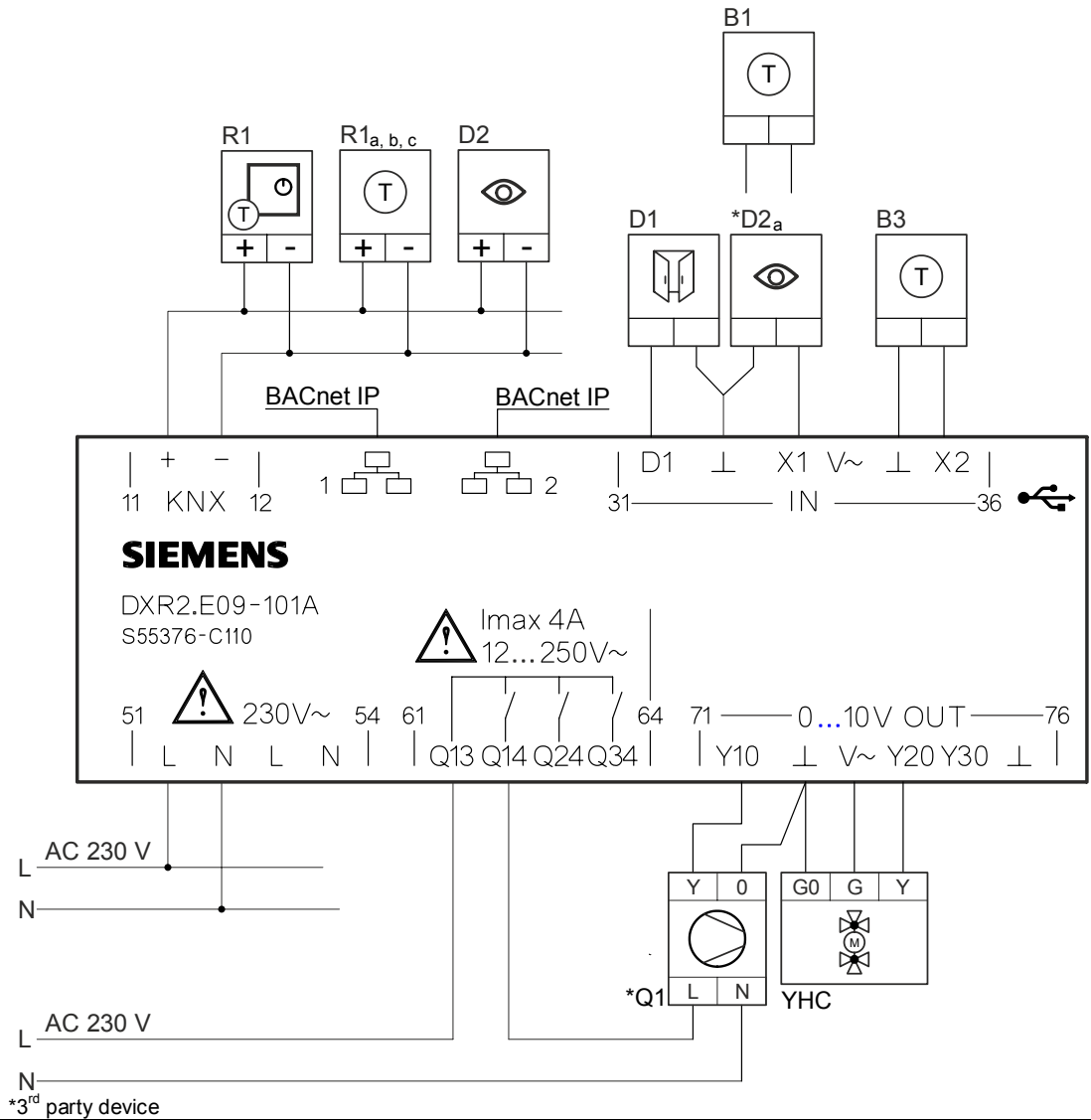

# Fan coil unit with variable fan, 6-way heating/cooling coil (4 pipe) on analog output

DXR2.E09-101A

## Application configuration

	Equipment	Values/Range	Template settings
On-board output	Fan speed	1-stage; Q14; Normally open 2-stage; Q14, Q24; Normally open 3-stage; Q14, Q24, Q34; Normally open Variable speed; Y10; 0...10 V	Variable speed; Y10; 0...10 V
	Enable fan speed	Q14; Normally open	Q14; Normally open
	Heating/cooling coil valve position	2-pipe; Y20; 0...10 V 2-pipe; Y30; 0...10 V 4-pipe 6-way; Y20; 0...10 V 4-pipe 6-way; Y30; 0...10 V	4-pipe 6-way; Y20; 0...10 V
KNX PL-Link devices	Room operator unit device 1	QMX3.P02, QMX3.P34, QMX3.P36, QMX3.P37, QMX3.P74	QMX3.P34

## Optional configuration

	Equipment	Values/Range	Template settings
On-board input	Room temperature (B1)		X1; LG-Ni1000
	Supply air temperature (B3)		X2; LG-Ni1000
	Presence detector 2 (D2 <sub>a</sub> )		X1, Normally open
	Window contact (D1)		D1; Normally closed
KNX PL-Link devices	Sensor device 1...4 (D2)		UP 258D12

## Default values

	Parameter	Values/Range	Template settings
Temperature setpoints	Cooling setpoint for Comfort	0 ... 50 °C	24 °C
	Delta cooling setpoint for Pre-comfort	0 ... 10 K	1 K
	Cooling setpoint for Economy	0 ... 50 °C	35 °C
	Cooling setpoint for Protection	0 ... 50 °C	40 °C
	Heating setpoint for Comfort	0 ... 50 °C	21 °C
	Delta heating setpoint for Pre-comfort	0 ... 10 K	1 K
	Heating setpoint for Economy	0 ... 50 °C	15 °C
	Heating setpoint for Protection	0 ... 50 °C	12 °C
Heating/cooling coil	Cooling coil valve position for value X1	0 ... 100 %	0 %
	Cooling coil valve position for value Y1	0 ... 100 %	50 %
	Cooling coil valve position for value X2	0 ... 100 %	100 %
	Cooling coil valve position for value Y2	0 ... 100 %	0 %
	Heating coil valve position for value X1	0 ... 100 %	0 %
	Heating coil valve position for value Y1	0 ... 100 %	50 %
	Heating coil valve position for value X2	0 ... 100 %	100 %
	Heating coil valve position for value Y2	0 ... 100 %	100 %
Room operator unit	Room unit, display temperature	None Display room temperature	Display room temperature
	Room unit, display windows status	Yes, No	No
	Room unit, display heat./cool. status	Yes, No	Yes
	Enable operation: room temp. setpoint	Yes, No	Yes

**Fan coil unit with variable fan, 6-way heating/cooling coil (4 pipe) on analog output** DXR2.E09-101A

**Default values**

	Parameter	Values/Range	Template settings
	Room unit, room temp. setpoint display	Absolute temperature setpoint Relative setpoint shift	Relative setpoint shift
	Enable operation: fan speed setpoint	Yes, No	Yes
	Enable operation: presence button	Yes, No	No
	Enable operation: temporary Comfort	Yes, No	No
	Enable operation: room op. mode	Yes, No	No
	Enable operation: Green Leaf	Yes, No	Yes

**Engineering**

- ABT Site engineering tool is required to configure the DXR2 automation stations.
- See the Siemens Download Center at [www.siemens.com/bt/download](http://www.siemens.com/bt/download) for the latest application configuration and workflow tutorials.
- Option combination according to available on-board I/Os on controller.
- B1 (optional extract air temperature sensor) to be configured under ‚Room temperature‘ in order to serve for room temperature control.
- D2<sub>a</sub> (on-board presence detector) to be configured in ABT Site under ‚Presence detector 2‘ for maximum combination of optional devices.  
Type of operation (NO or NC). Multiple devices of the same type can be connected.

**Management station**

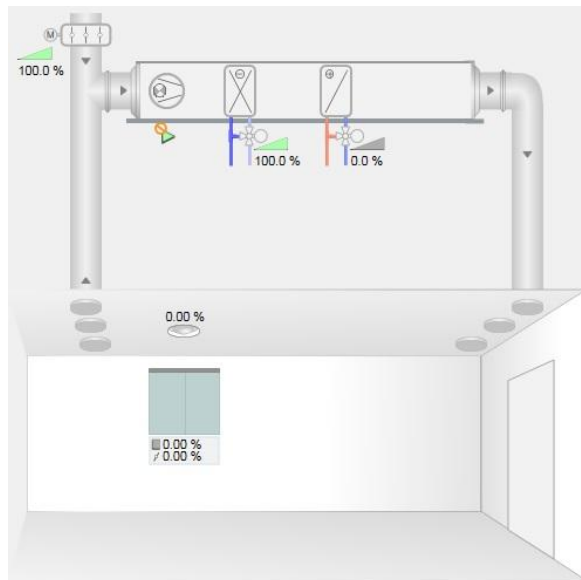

Sample presentation of a fan coil unit application on the Desigo CC management station.

Siemens Switzerland Ltd  
Building Technologies Division  
International Headquarters  
Gubelstrasse 22  
CH-6301 Zug  
Tel. +41 41-724 24 24  
Fax +41 41-724 35 22  
[www.siemens.com/buildingtechnologies](http://www.siemens.com/buildingtechnologies)

© 2015 Siemens Switzerland Ltd  
Subject to change