

Desigo™ PX

Extension module

PXX-PBUS

Integration of existing PT-I/O modules in Desigo
Used with PXC50...D, PXC100...D or PXC200...D

The PXX-PBUS extension module allows for integrating existing PT-I/O modules in Desigo.

The PXX-PBUS extension module, when combined with a PXC50...D / PXC100...D / PXC200...D automation station and TXS1.12F10 supply module, replaces the UNIGYR and VISONIK process units as well as the PXC64-U, PXC128-U automation stations.

- PT-I/O modules can continue to be used.
- Existing periphery can be assumed without a change.
- Control panel wiring can be assumed and need only be supplemented by new supply modules.

See installation manual PT modules, M8102.

Type summary

Type	Stock number	Name
PXX-PBUS	S55842-Z107	Extension module

Equipment combinations

Types	Description	Data sheet
PXC50.D, PXC100.D, PXC200.D	Automation station (BACnet/LonTalk)	CM1N9222
PXC50-E.D, PXC100-E.D, PXC200-E.D	Automation station (BACnet/Ethernet)	CM1N9222
TXS1.12F10	Power supply module (TX-I/O)	CM2N8183
PXA-H1	Cover (option for PXM10, PXM20, PXM20-E)	--

Function

Existing module carriers with PT-I/O modules can be connected to the PXX-PBUS extension module. All PT-I/O-Module are supported: PTM1... , PTM6.1PSI20-M, PTK1.23V02, PTK1.30V01, PTM50... , PTM52... , PTE-ASED.20, PTE-SED2 (see also PX Hardware overview N9202).

The device serves as P-bus interface for modular automation stations PXC50...D, PXC100...D or PXC200...D in Desigo.

The PT-I/O modules must now be supplied via the TXS1.12F10 supply module. In current installations, module supply was integrated in the UNIGYR/VISIONIK process units or the PXC64-U / PXC128-U automation stations.

One TXS1.12F10 supply module is needed for each PBUS strand (at max. 64 load units each).

A separate transformer must be used to supply remote PT-I/O modules.

To connect to the PT-I/O modules, the device contains:

- One 4-pole plug with screw terminals for the P-bus (above).
- One 4-pole plug with screw terminals for the P-bus 2 (below).

Hardware

Hardware consists of

- a system controller PXC50...D / 100...D / 200...D
- and an extension module PXX-PBUS.

Topology

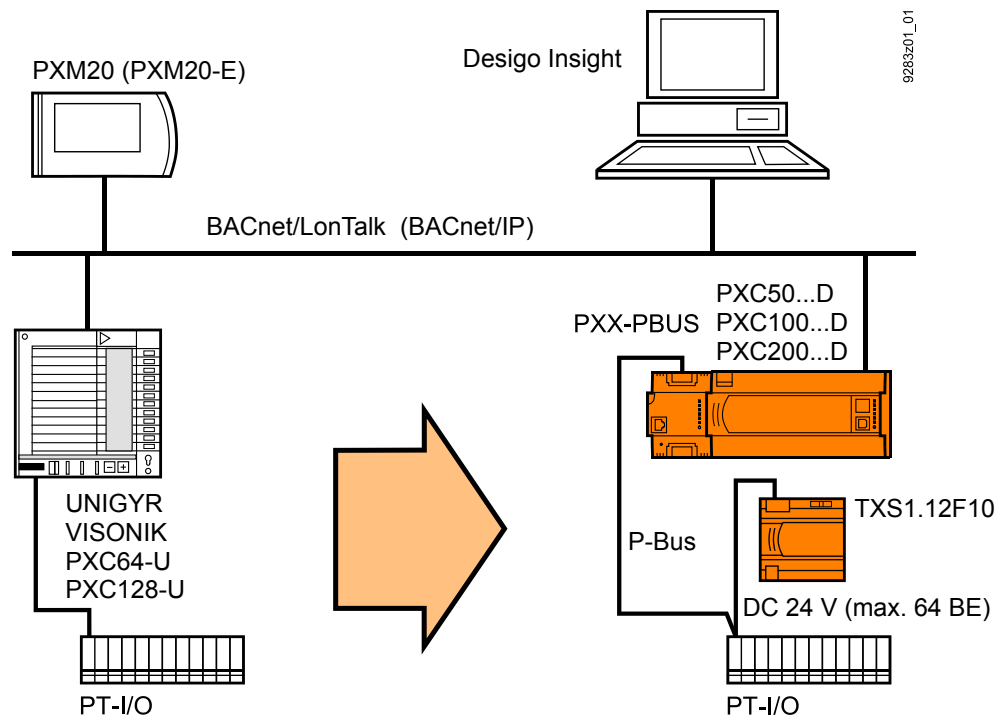

The compact build allows for mounting the extension modules in very narrow spaces.

Housing

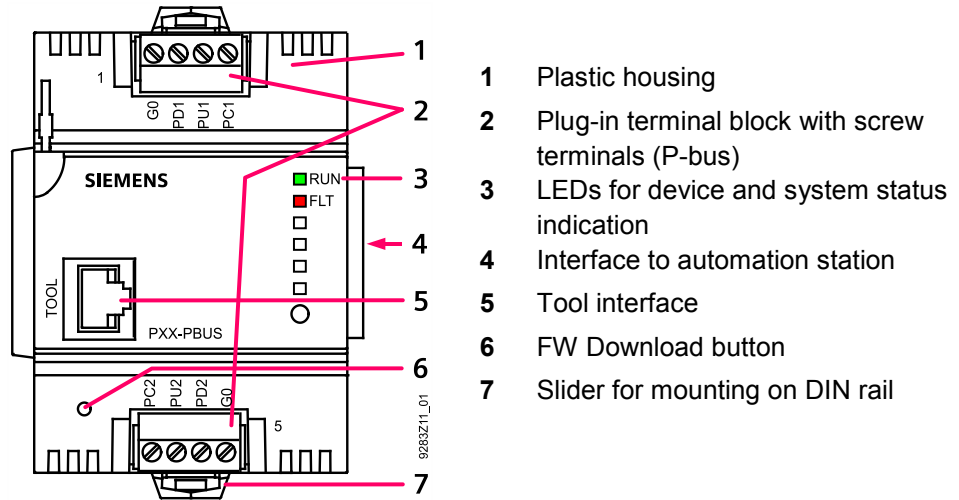

LED display, buttons

LED	Color	Activity	Meaning / → Corrective action
RUN	Green	Continuously off	No power supply. → Check power supply.
		Continuously on	Power supply ok; firmware functions ok.
FLT	Red	Continuously off	Everything ok.
		Continuously on	Hardware fault detected during self-test. → PXX-PBUS module must be replaced.
		Fast flashing	No valid firmware present. → Reload firmware.
○		FW Download	Press using pointy object.

Disposal



The devices are considered electronics devices for disposal in terms of European Directive 2012/19/EU (WEEE) and may not be disposed of as domestic waste. Dispose of the devices via the proper channels. Follow all local and currently applicable laws and regulations.

Mounting

The extension module PXX-PBUS can be snapped onto standard DIN rails.

To connect, push the extension module from left to the PXC50...D / PXC100...D / PXC200...D automation station until the interfaces establish a connection.

Note You can insert cover frame PXA-H1 in the control panel front to cover the opening rather than a PXC64-U / PXC128-U automation station. It can be used as a carrier for the PXM10/20, PXM20-E operator unit.

Use cases

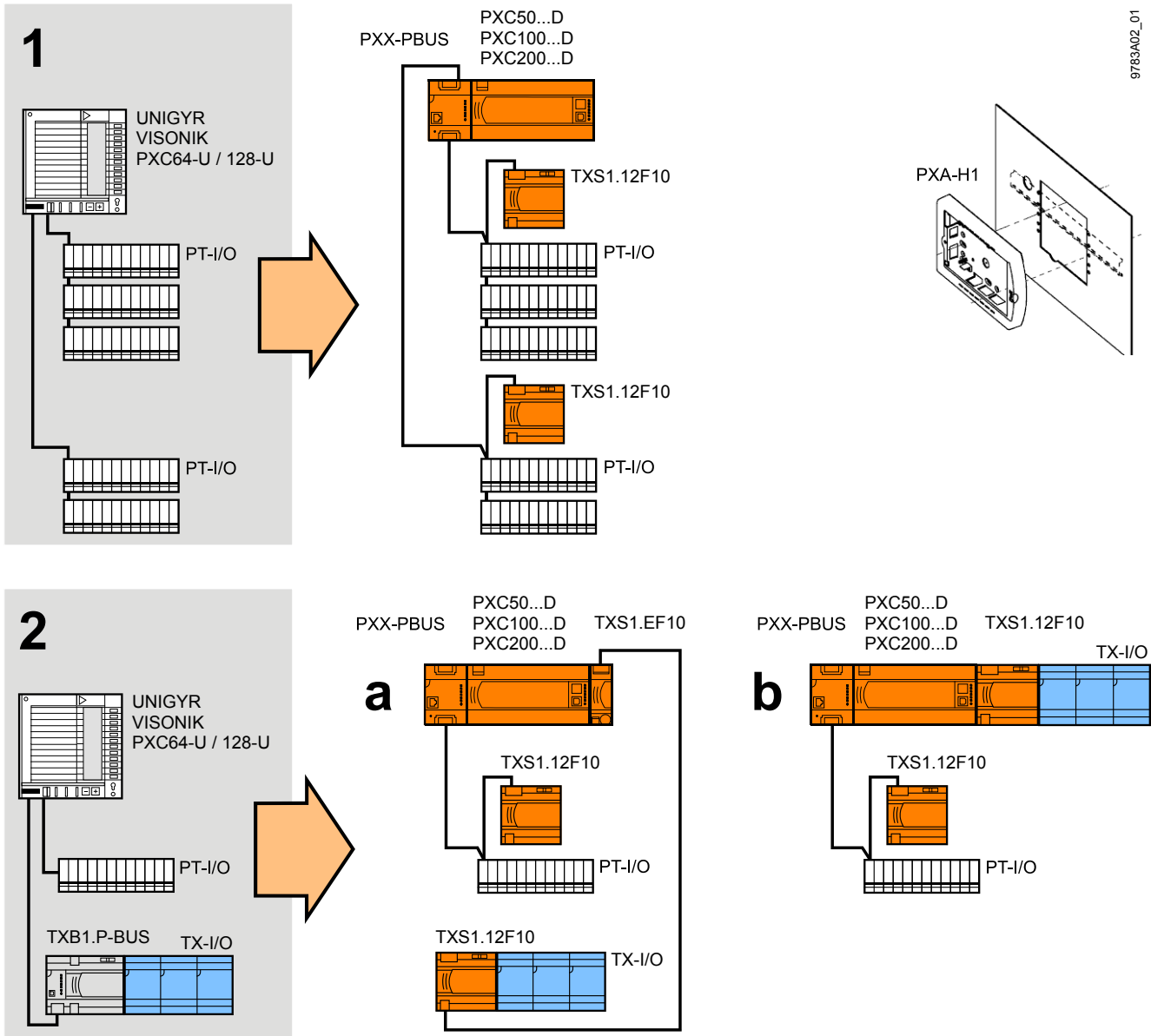

9783A02_01

Additional elements

The following additional elements are needed to migrate from a UNIGYR/VISIONIK process unit (or from a PXC64-U / PXC128-U automation station) to a PXC....D automation station:

- Supply module TXS1.12F10 as bus supply for the P-bus for each P-bus strand. Max. 64 load units can be supplied (1 LU = 12.5 mA, DC 24 V) *)
- Existing TX-I/O modules also require a separate supply module TXS1.12F10, as the P-bus-BIM TXB1.P-BUS and its supply function can no longer be used. *)
- The existing P-bus cabling must be extended by one additional line for G0 (1.5 mm² diameter).
- A PXA-H1 frame can be inserted in the control panel door to cover the opening rather than a PXC...-U automation station. It can be used as a carrier for the PXM10, PXM20, PXM20-E operator unit.

STOP Note!

*) The admissibility of the number of load units is checked in the XWP.

Installation

Binding documentation The electrical diagram for the specific project is binding for executing the given panel wiring.

Basic implementation The diagram below illustrates the wiring for power and bus line based on an example.

Note The AC 230 V wiring is not described in detail.

Wiring example for automation station PXC50...D / PXC100D / 200....D

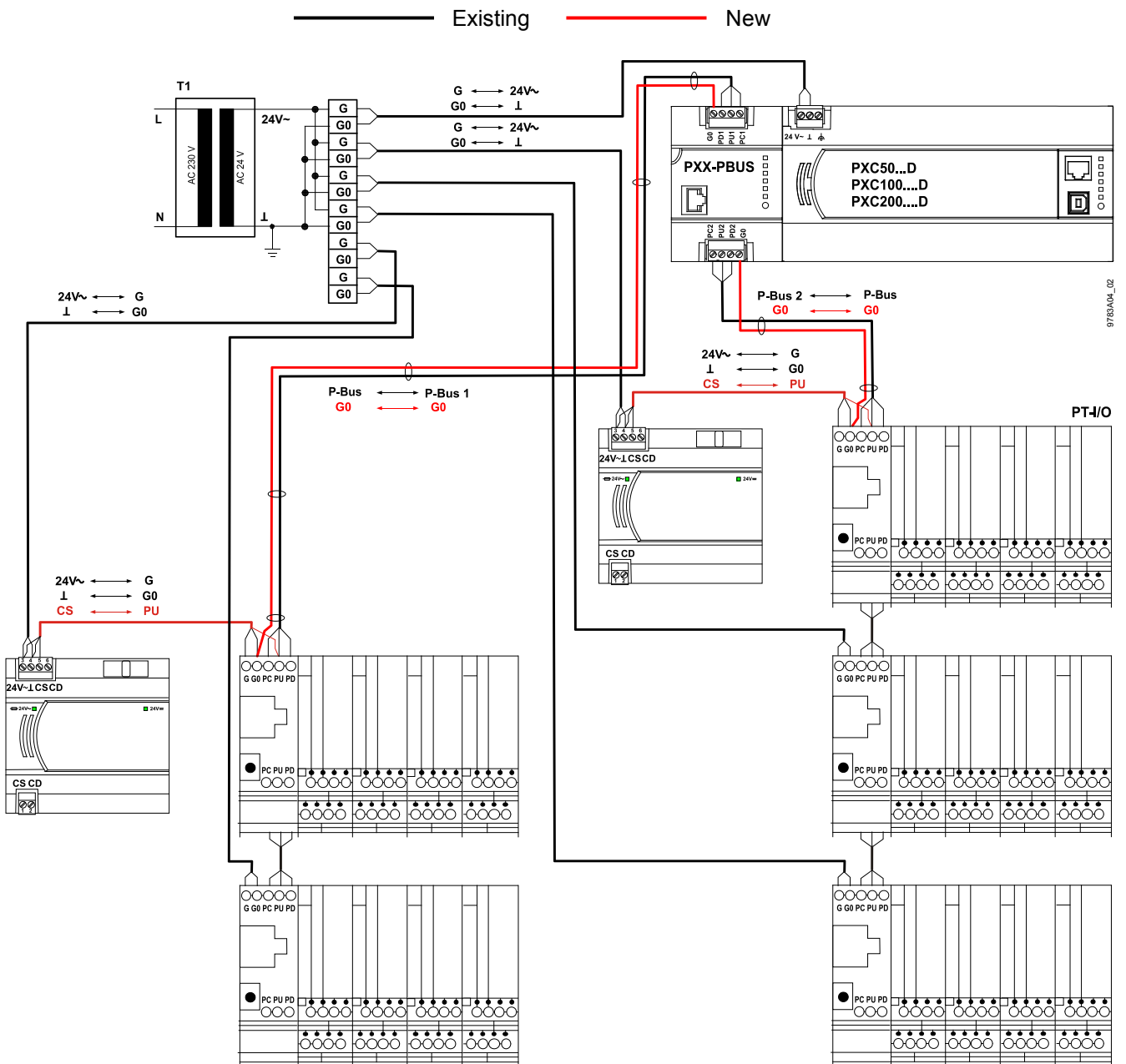

Technical data

General device data	Power supply module	DC 24 V ±20% (SELV) or DC 24 V class 2 (US) 54 mA, 1.4 W from automation station PXC50...D / PXC100...D / PXC200...D
P bus interface	Polling cycle on I/O modules Rate of transmission Signal level Wiring Cross-section Simple line length (see P-bus, N8022) Line length (remote P-bus) (see P-bus, N8022)	0.3 s 62,5 kBaud DC +23 V and 0 / –5 V Min. 3 x 0.75 mm ² Max. 50 m per P-bus terminal block Max. 200 m per P-bus terminal block
Connection terminals, pluggable	Design type Copper wire or copper stranded wires with ferrules Cu-strand without wire end sleeve Screwdriver Max. tightening torque	Pluggable screw terminals 1 x 0.6 mm dia. to 2.5mm ² or 2 x 0.6 mm dia. to 1.0 mm ² 1 x 0.6 mm dia. to 2.5 mm ² or 2 x 0.6 mm dia. to 1.5 mm ² Slot screws Screwdriver, size 1 <i>with shaft dia. ≤ 4.5 mm</i> 0.6 Nm
Protection data	Housing protection standard Protection class	IP30 (IP30) to EN 60529 III to EN 60730-1
Ambient conditions	Normal operation Temperature Humidity Transport Temperature Humidity	Class 3K5 to IEC 721 0 ... 50 °C < 85% r.h. Class 2K3 to IEC 721 – 25 ... 65 °C < 95% r.h.
Standards, directives and approvals	Product standard EN 60730-1 Electromagnetic compatibility (Applications)	Automatic electrical controls for household and similar use For use in residential, commerce, light-industrial and industrial environments
	EU conformity (CE) UL certification (US) RCM-conformity (EMC) EAC conformity FCC	CM1T9283xx *) UL 916, http://ul.com/database CM1T9222en_C1 *) Eurasia conformity 47 CFR Part 15 Class B
Environmental compatibility	Product environmental declaration (contains data on RoHS compliance, materials composition, packaging, environmental benefit, disposal)	CM1E9293 *)
Dimensions	See "Dimensions"	
Weight	With/without packaging	0.129 kg / 0.140 kg

*) The documents can be downloaded from <http://siemens.com/bt/download>.

PXX-PBUS

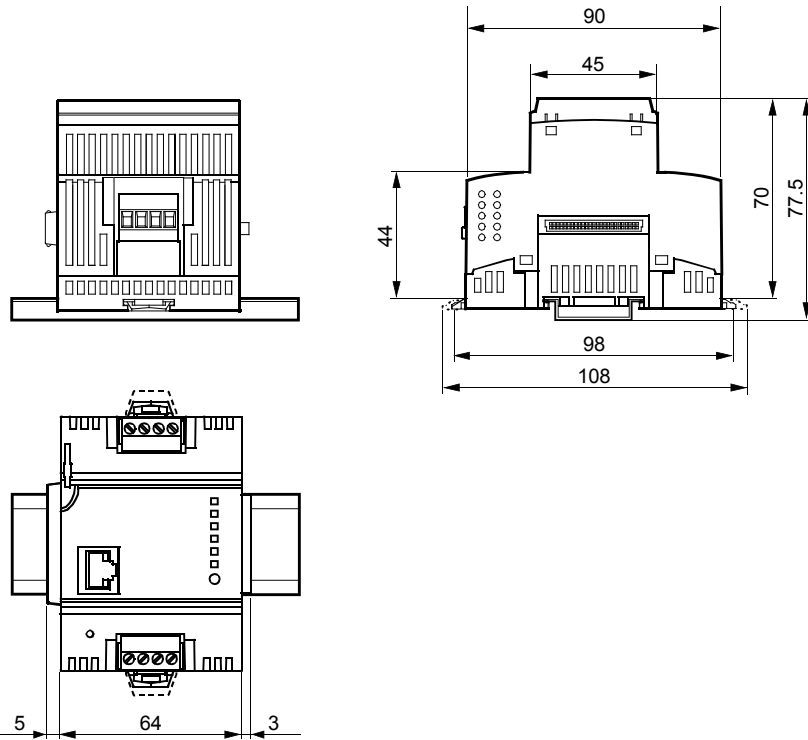

**PXX-PBUS with one automation station
PXC50...D / PXC100...D /
PXC200...D**

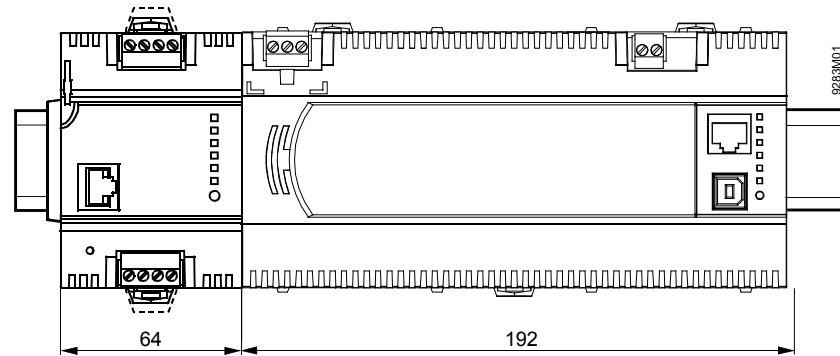

**Power supply module
TXS1.12F10**

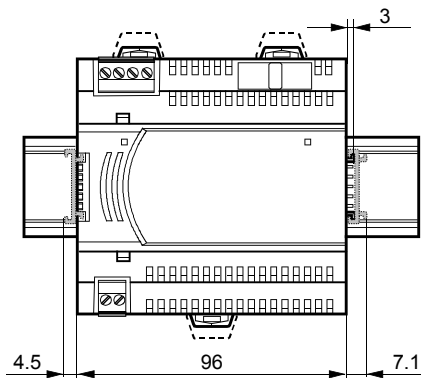

Published by:
Siemens Switzerland Ltd.
Building Technologies Division
International Headquarters
Gubelstrasse 22
6301 Zug
Switzerland
Tel. +41 41-724 24 24
www.siemens.com/buildingtechnologies

© Siemens Switzerland Ltd 2012
Delivery and technical specifications subject to change