



VGS1... with  
AGA67 connector



VGS2... with  
AGA67 connector

## Solenoid gas valve

## VGS...

The solenoid gas valve is also applicable as

- a main gas valve
- Pilot gas valve for forced draft burners

The VGS... and this Data Sheet are intended for use by OEMs which integrate the burner controls in their products.

### Use

- Safety shutoff valve, for gas class A to EN 161
- Fast opening
- For gas types I...III
- Connector with integrated rectifier
- VGS2... with flow rate adjustment
- VGS2... with strainer

## Warning notes

---



**To avoid injury to persons, damage to property or the environment, the following warning notes must be observed!**

### **Do not open, interfere with or modify the solenoid gas valves!**

- All activities (mounting, installation and service work, etc.) must be performed by qualified staff.
- Before making any wiring changes in the connection area of the VGS..., completely isolate the solenoid gas valve from mains supply (all-polar disconnection). If not observed, there is a risk of electric shock hazard
- Each time work has been carried out (mounting, installation and service work, etc.), check to ensure that wiring is in an orderly state and make the safety checks
- When used in connection with gas, the solenoid gas valves constitute part of the safety equipment
- Fall or shock can adversely affect the safety functions. Such solenoid gas valves must not be put into operation, even if they do not exhibit any damage

## Mounting notes

---

- Ensure that the relevant national safety regulations are complied with
- For the electrical connection a connecting plug must be used according to DIN EN 175301-803-A with built-in rectifier
- Check to ensure that the valve is tight when all components are connected

## Installation notes

---

- Remove the protecting caps at the connection threads
- Make sure that the flow direction is correct
- The direction of gas flow must be in accordance with the direction of the arrow on the valve body
- Check the correct connection of the plug, tighten the screw of the plug
- Avoid contaminations inside the solenoid gas valves, e.g. by dealing material
- The valve may not be used as a lever during the mounting, use suitable tool
- Use suitable gas filters
- VGS1...: Internal **without** strainer
- VGS2...: Internal **with** strainer
- Connection with AGA67 (rectifier side)

## Standards and certificates

---



Conformity to EEC directives  
- Electromagnetic compatibility EMC (immunity)  
- Directive for gas appliances  
- Low-voltage directive

2004/108/EC  
90/396/EEC  
97/23/EEC



ISO 9001: 2000  
Cert. 00739



ISO 14001: 2004  
Cert. 38233



## Service notes

- Each time a valve has been replaced, check to ensure that the valve operates correctly and that it is tight both internally and externally
- Siemens solenoid gas valves may **only** be overhauled by Siemens Repair Centers or their approved partners
- If failure of the VGS... the complete valve must be replaced

## Life cycle

Solenoid gas valves has a designed lifetime\* of 500,000 burner startup cycles which, under normal operating conditions in heating mode, correspond to approx. 10 years of usage (starting from the production date given on the type field). This lifetime is based on the endurance tests specified in standard EN161 and the table containing the relevant test documentation as published by the European Association of Component Manufacturers (Afecor) ([www.afecor.org](http://www.afecor.org)).

The designed lifetime is based on use of the solenoid gas valves according to the manufacturer's Data Sheet. After reaching the designed lifetime in terms of the number of burner startup cycles, or the respective time of usage, the solenoid gas valve is to be replaced by authorized personnel.

\* The designed lifetime is not the warranty time specified in the Terms of Delivery

## Disposal notes



The VGS... contains electrical and electronic components and must not be disposed of together with household waste. Local and currently valid legislation must be observed.

## Type summary (other types of solenoid gas valves on request)



Type reference	Mains voltage	Connecting size	Inlet pressure max. (mbar)	Flow rate adjustment	Weight (kg)	Rated input (VA)
VGS10.104E2 <sup>1)</sup>	AC 230 V	3/8"	1000	---	0.6	20
VGS10.154E2 <sup>1)</sup>	AC 230 V	1/2"	1000	---	0.6	20
VGS27.154E2 <sup>1)</sup>	AC 230 V	1/2"	750	x	2.3	21.2
VGS25.204E2 <sup>1)</sup>	AC 230 V	3/4"	750	x	2.3	21.2
VGS23.254E2 <sup>1)</sup>	AC 230 V	1"	750	x	2.5	21.2

<sup>1)</sup> AC 24 V / AV 115 V on request



**Connector** to VGS... for power supply

**AGA67**

- plug connection to DIN EN 175301-803-A
- with integrated bridge rectifier , able for voltage range of AC 24...230 V
- 2-pole + 
- $\varnothing$  6...8 mm / max. 1.5 mm<sup>2</sup>
- including profile gasket



Example: VGS1... with connector AGA67



**Cable entry must not face upwards!**

## Technical data

General unit data	Threaded connection	ISO 7-1
	Opening time	< 1 s
	Closing time	< 1 s
	Housing material	
	- VGS1...	Brass
	- VGS2...	Aluminium
	Degree of protection	IP65 to IEC 529
	Inlet pressure	refer to «Type summary»
	Valve class	A to EN 161
	Group	2
Electrical characteristics	Rated input	refer to «Type summary»
	Main voltage	refer to «Type summary»
	Mains frequency	50 / 60 Hz $\pm$ 5 %
	On time	100 %
	Safety class	SK I / II
Environmental conditions	<b>Storage</b>	DIN EN 60 721-3-1
	Climatic conditions	class 1K3
	Mechanical conditions	class 1M2
	Temperature range	-10...+60 °C
	Humidity	< 95 % r.h.
	<b>Transport</b>	DIN EN 60 721-3-2
	Climatic conditions	class 2K2
	Mechanical conditions	class 2M2
	Temperature range	-10...+60 °C
	Humidity	< 95 % r.h.
	<b>Operation</b>	DIN EN 60 721-3-3
	Climatic conditions	class 3K3
Mechanical conditions	class 3M3	
Temperature range	-10...+60 °C	
Humidity	< 95 % r.h.	



**Condensation, formation of ice and ingress of water are not permitted!**

**Function**

VGS... are solenoid gas valves, closed dead.

In addition, VGS2... have a flow rate adjustment, which one can be altered with an allen key or allen wrench 6 mm manually.

**Connection diagram AGA67**

Connection plug for solenoid gas valve with integrated rectifier.

→ Required for connection to the VGS... solenoid gas valve.

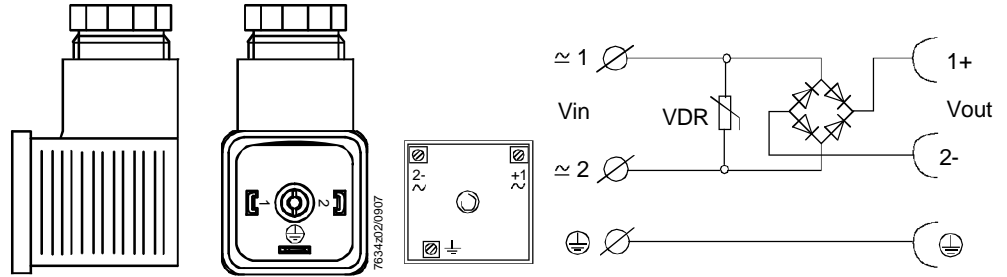

**Flow curves**

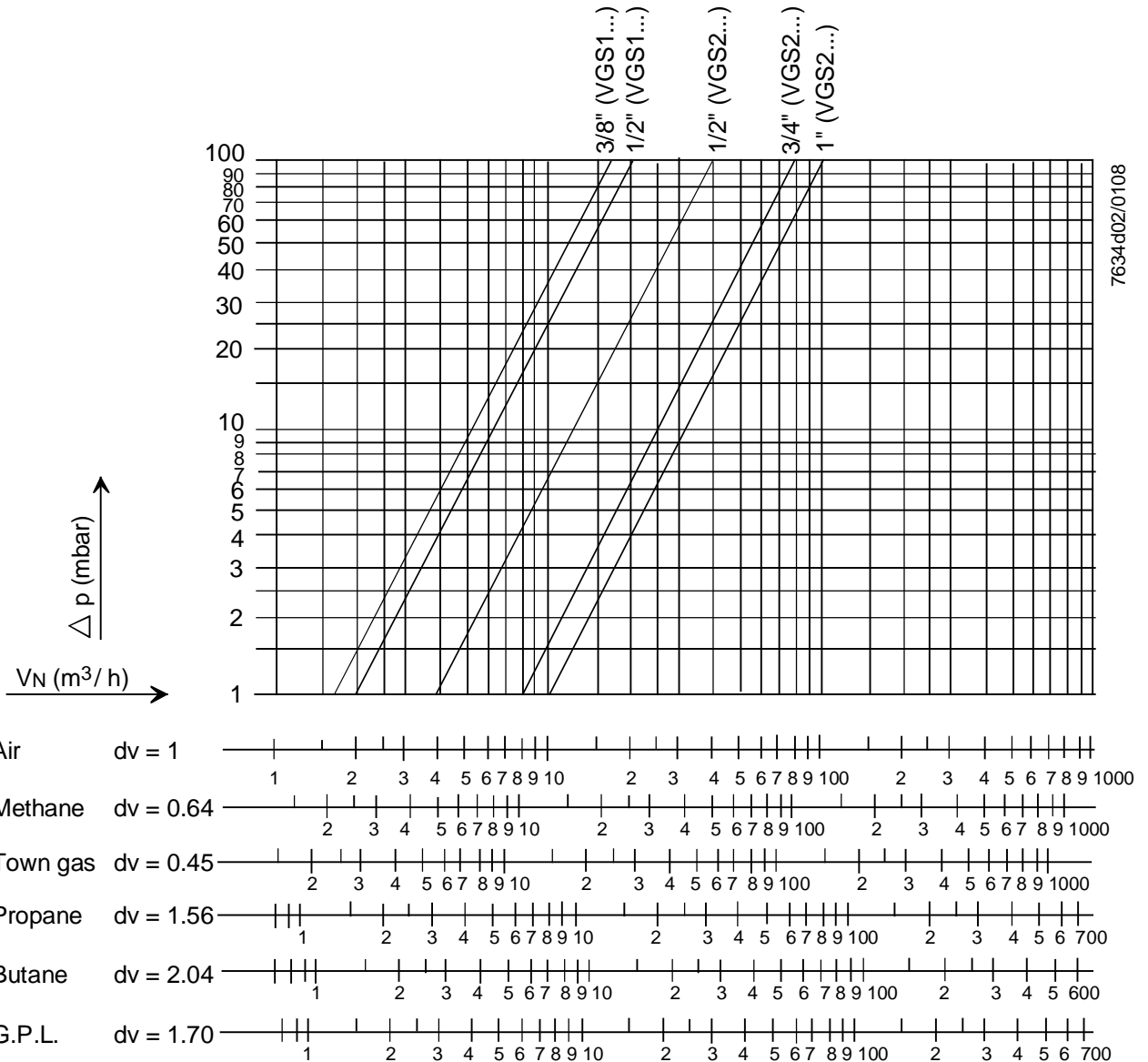

## Dimensions

Dimensions in mm

VGS1...

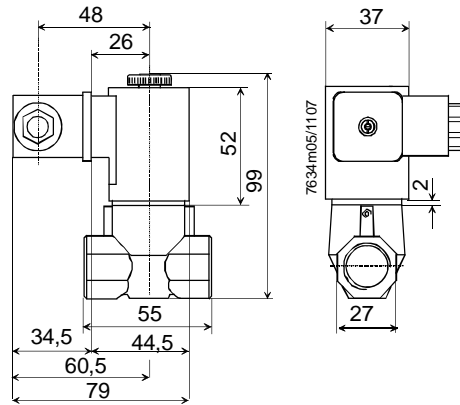

Type	Thread (Rp)	Seat Ø	Weight approx. (kg)
VGS10.104E1	3/8"	8	0.6
VGS10.104E2	3/8"	8	0.6
VGS10.104E8	3/8"	8	0.6
VGS10.154E1	1/2"	10	0.6
VGS10.154E2	1/2"	10	0.6
VGS10.154E8	1/2"	10	0.6

Dimensions (cont'd)

Dimensions in mm

VGS2...

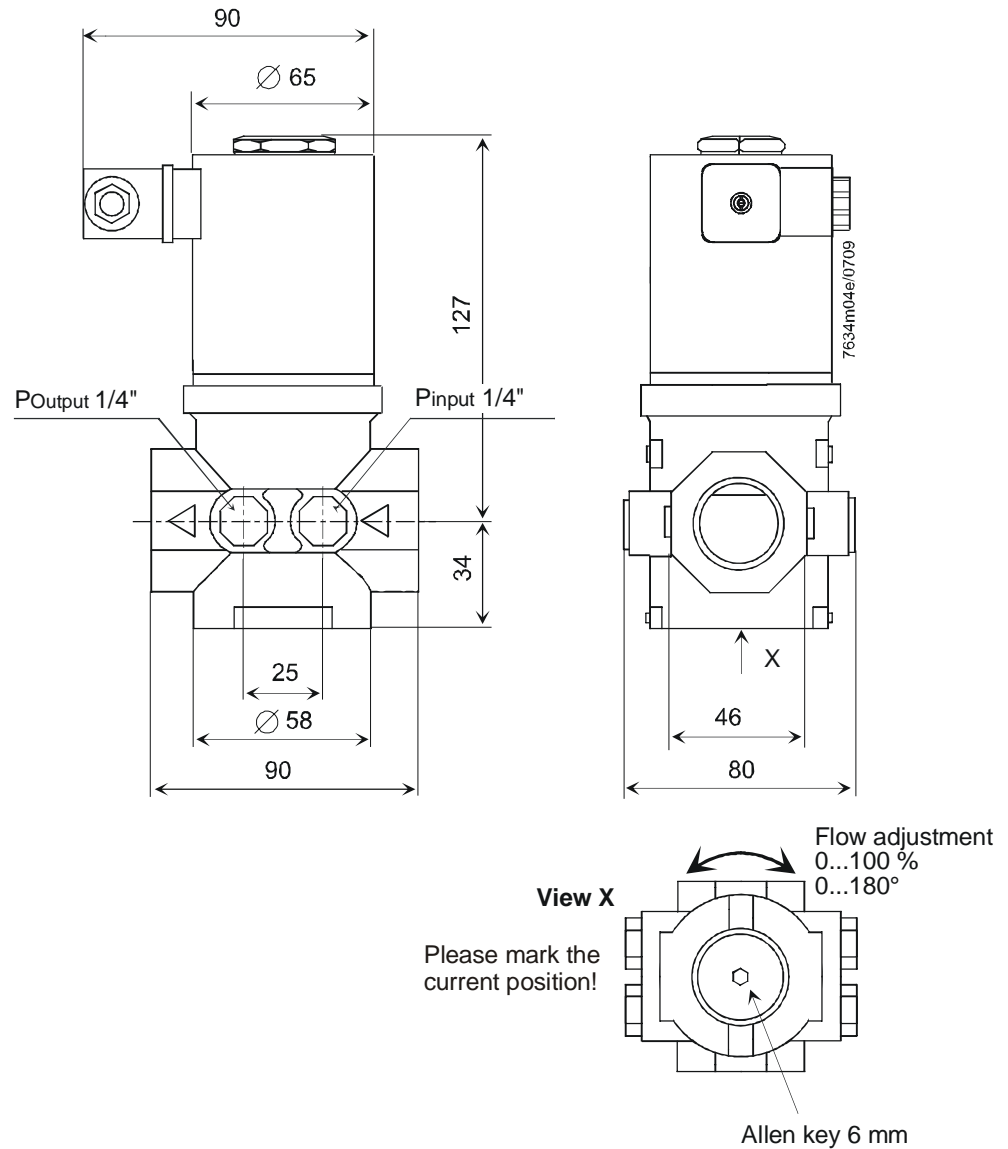

Type	Thread (Rp)	Seat ∅	Weight approx. (kg)
VGS27.154E1	1/2"	17	2.3
VGS27.154E2	1/2"	17	2.3
VGS27.154E8	1/2"	17	2.3
VGS25.204E1	3/4"	20	2.3
VGS25.204E2	3/4"	20	2.3
VGS25.204E8	3/4"	20	2.3
VGS23.254E1	1"	25	2.5
VGS23.254E2	1"	25	2.5
VGS23.254E8	1"	25	2.5