



PolyCool™

## Superheat Controller

## RWR462.10

For chillers, air conditioning units, etc.

- Standalone electronic superheat controller RWR462.10 for use with any type of dry expansion evaporator in refrigeration plants.
- The MOP (Maximum Operating Pressure) function and the monitoring of sensors and minimum superheat are integrated.
- The controller can be included in the chiller's safety circuit.
- Optionally, control of the cooling capacity can be configured.
- It operates on AC / DC 24 V.
- All required data are entered on the controller. No tools needed.

**Use**

The PolyCool™ superheat controller with its associated components ensures optimum operation of the refrigeration unit.

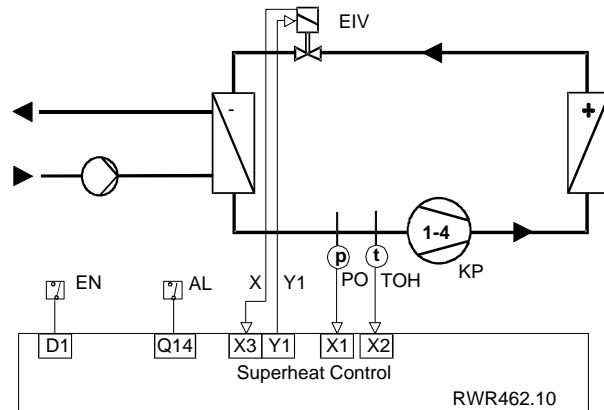

**Field of use**

The controller ensures optimum filling of the evaporator under all load conditions, resulting in low energy consumption. Various monitoring functions enhance operating safety and extend the plant's life.

The controller has been designed for use with all standard types of dry expansion evaporators such as plate, tube and fin heat exchangers and is therefore especially suited for integration in chillers, air handling units, etc.

**Auxiliary functions**

Auxiliary functions enhance efficiency and supervision of the refrigeration plant:

- Enabling operation via a digital input, e.g. by any operational status signal from the compressor
- Selection of different types of refrigerants
- Conversion of pressure to the respective temperature of the selected refrigerant
- Display of all measuring variables and of the valve's manipulated variable
- Integrated cooling capacity control
- Two superheat circuits
- Sensor monitoring
- Compressor safety controls

**Type reference**

Type reference	Inputs		Outputs	
	Analog / Digital	Digital	Analog	Digital
<b>RWR462.10</b>	5	2	2	2

**Customized controllers**

Siemens HVAC Products also supplies customer-specific controllers that differ from the standard products in terms of refrigerant selection and / or outer appearance. Please contact us if you require customized products.

## Peripheral devices

Siemens  
HVAC Products

The PolyCool™ superheat controller uses two types of sensors and one valve made by Siemens HVAC Products.

Field devices	Type	Measuring range	Signal	Data sheet no.
Cable Temperature Sensor	QAZ21.682/101	-50...80° C	Resistance sensor LG-Ni 1000	N1848
Pressure sensor	- QBE9103-P10U* - QBE9103-P30U* - QBE9103-P60U*	-1...9 bar -1...29 bar -1...59 bar	DC 4...20 mA DC 4...20 mA DC 4...20 mA	A6V10451440
	- QBE2004-P10U - QBE2004-P25U - QBE2004-P60U	-1...9 bar -1...24 bar -1...59 bar	DC 0...10 V DC 0...10 V DC 0...10 V	A6V10434676
Refrigerant valve	-MVL661...-/ MVS661.25-..		DC 0...10 V	N4714/N4717

\* Replacement sensor for service **QBE2104-P10U / P30U / P60U**



The controller and the above mentioned peripheral devices have been matched to the application covered by this data sheet. Therefore, valve and sensors may not be replaced by products of other manufacture.

Note

Safety transformer (25 VA) to EN 60 742 is **not** included in the delivery.

## Configurable functions

The controller's functions are preconfigured. By changing the parameters, the functions can be matched to the type of plant.

### Selection of refrigerant

Control of the evaporator is based on true superheat control. For this purpose, pressure **P0** acquired at the evaporator output is converted to the respective temperature of the refrigerant used.

The controller contains the polynomials of the following types of refrigerants:

R22	R23	R32	R125	R134a	R152a	R170*	R227ea <sup>1</sup>
R236fa <sup>2</sup>	R245fa <sup>3</sup>	R290*	R401A	R401B	R401C	R402A	R402B
R404A	R406A	R407A	R407B	R407C	R407F	R408A	R409A
R410A	R410B	R413A	R417A	R421A	R422A	R422D	R427A
R434A	R437A	R438A	R502	R507	R600*	R600a*	R717**
R723	R744	R1270*					

1) Displayed as R227E

2) Displayed as R236F

3) Displayed as R245F



Important

\* Hydrocarbons: Can only be used for explosion-proof valves!

\*\* R717 (NH3): Requires the use of valves suited for ammonia, e.g. MVS661.25-...

### Selection of units

The temperature can be displayed in °C (**K**) or °F, and the pressure in **Bar** or **Psi**. EIV opening can be displayed in **V** or **%**.

### Selection of application

For the default: Pure superheat control

It is possible to configure the following three different applications.

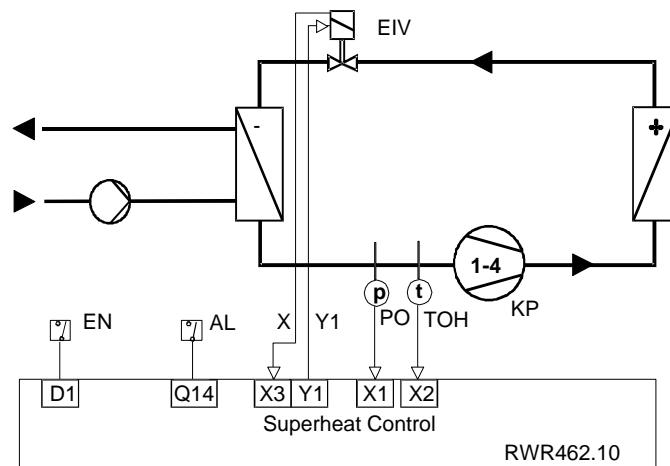

### External capacity control

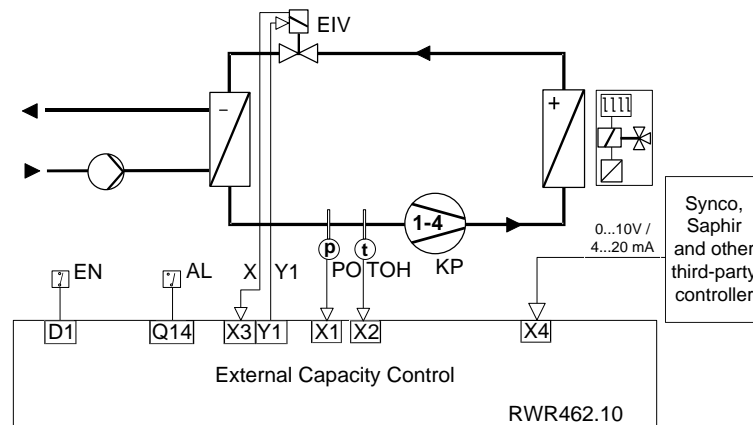

### Internal capacity control

**TM** = Medium temperature sensor:  
Ni1000 or temperature sensor with DC 0...10 V / 4...20 mA measuring signal

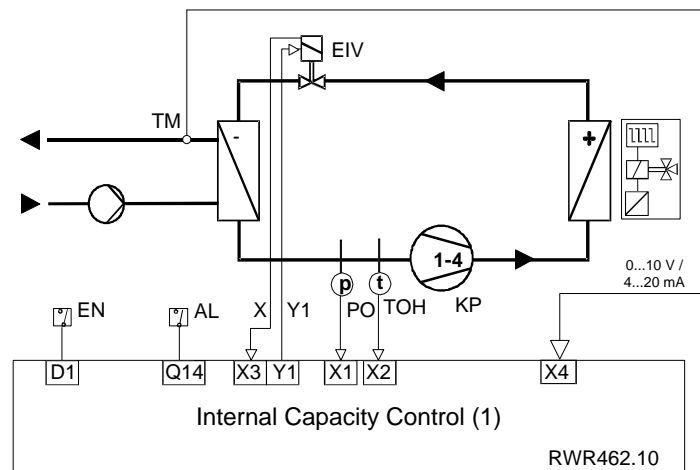

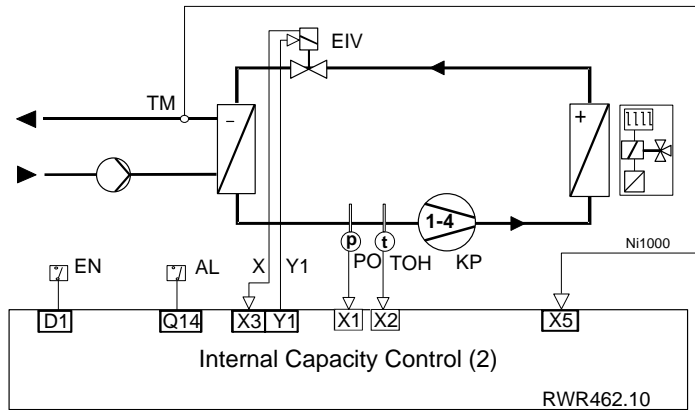

Two superheat circuits

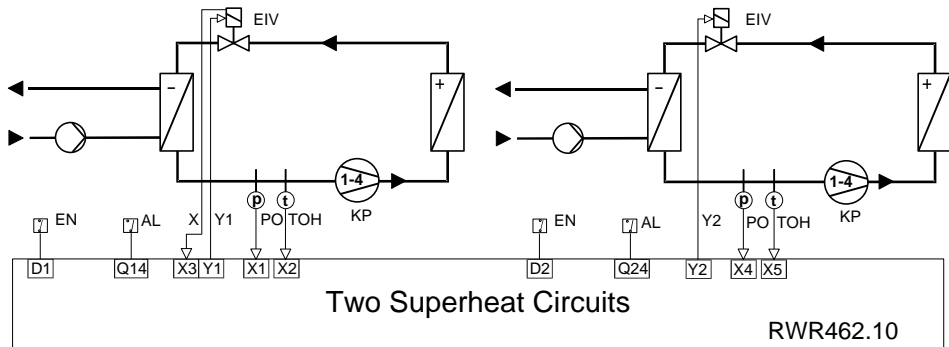

Note

This controller can be applied to two pure superheat control circuits, but only one EIV feedback can be input (terminal X3). The simulation mode is possible for one circuit only (for simulation mode, refer to pages 7 and 12).

Superheat control

The superheat controller monitors the temperature differential between the suction gas temperature and the calculated evaporation temperature (TOH-TO) to maintain the adjusted setpoint  $\Delta T$ .

The electronic injection valve is controlled via analogue output Y1 (Y2 for Circuit 2).

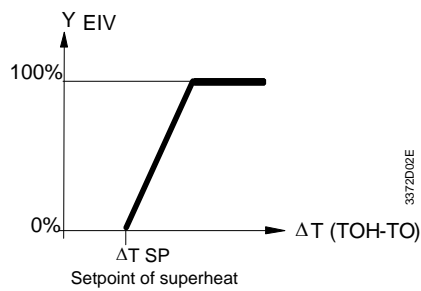

## External capacity control

### External capacity control (only for one single circuit)

The capacity of the refrigeration unit drops as the superheat increases. Using a DC 0...10 V / 4...20 mA signal, the setpoint of superheat control can be increased via input X4. The signal is calculated and delivered by an external controller (i.e. Synco, Saphir and other third-party controller), based on the measured medium temperature.

The setpoint of superheat is increased proportionally as a function of the voltage at input X4. The maximum increase (SMX) corresponds to DC 10 V / 20 mA or 0 V / 4 mA based on the configuration of external signal direction (SD), and can be entered in the parameter mode. The setpoint used for superheat control represents the sum of the setpoint of overheating ( $\Delta T$  SP) entered in the parameter mode plus the increase.

## Internal capacity control

### Internal capacity control (only for one single circuit)

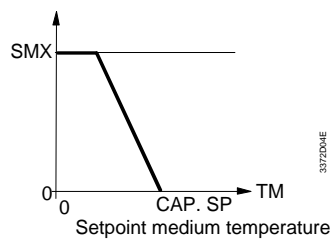

The temperature of the medium is acquired via an input. Depending on the configuration of input, it is possible to choose a passive Ni1000 sensor (X5) or an active DC 0...10 V / 4...20 mA sensor (X4). The measurement range of the active sensor can be set between -99.9 °C and 99.9 °C.

Internal capacity control controls the medium temperature TM according to the setpoint (CAP. SP) entered in the parameter mode in that it reduces the capacity of the refrigeration unit by increasing the setpoint of superheat control. The maximum increase (SMX) is entered in the parameter mode.







## Standard functions

---

<b>Enable</b>	In general, the control and monitoring functions are enabled by an operational status signal received from the plant.
<b>Digital input D1 / D2</b>	When feeding an AC / DC 24 V signal (i.e. operational status signal from the compressor) to the digital input D1 (D2 for circuit 2), the control of the evaporator and the safety functions for the compressor will be activated.
<b>Protective functions for the compressor</b>	<p>To ensure the reliability of the refrigeration plant and to prolong the life of the compressor, the following protective functions have been integrated:</p> <ul style="list-style-type: none"><li>• <b>Minimum limitation of superheat</b> To protect the compressor from <b>shocks caused by liquid refrigerant</b>, the valve will be closed in modulating mode when the minimum superheat falls below the selected parameter value (MI) i.e. 2 K. (3.6 °F).</li><li>• <b>MOP function [MOP]</b> Limitation of the maximum evaporation pressure is another protective function provided for the compressor. It operates in PI mode and overrides the normal control function to maintain the maximum evaporation temperature.</li></ul>
<b>Operating safety</b>	When power is supplied to the controller, relay Q14 (Q24 for circuit 2) will be energized. The following actions protect automatic control operation against faults at the universal inputs X_.
<b>Evaporation pressure P0</b>	<ul style="list-style-type: none"><li>• <b>Measurement of pressure P0</b> A measured value of <math>\leq 0</math> V or <math>\geq 10</math> V (<math>\leq 4</math> mA or <math>\geq 20</math> mA) produces the following effects:<ul style="list-style-type: none"><li>– The alarm icon  flashes, and the LCD displays <b>ERR</b> in place of the actual value of superheat <math>\Delta t</math>, and the respective range limit indicator, low (<b>LO</b>) or high (<b>HI</b>), will flash</li><li>– The controller's output Y1 (Y2 for circuit 2) switches to 0 V</li><li>– Relay Q14 (Q24 for circuit 2) will be de-energized *</li></ul></li></ul> <p>* When returning to the normal operational values, relay Q14 (Q24) will automatically be energized again.</p>
<b>Suction gas temperature TOH</b>	<ul style="list-style-type: none"><li>• <b>Measurement of suction gas temperature TOH</b> For any short-circuit or open-circuit detected:<ul style="list-style-type: none"><li>– The alarm icon  flashes, and the LCD displays <b>FAIL</b> in place of the actual value of superheat <math>\Delta t</math></li></ul></li><li>• A measured value of <math>\leq TL</math> or <math>\geq 80^{\circ}\text{C}</math> will produce the following effects:<ul style="list-style-type: none"><li>– The alarm icon  flashes, and the LCD displays <b>ERR</b> in place of the actual value of superheat <math>\Delta t</math>, and the respective range limit indicator, low (<b>LO</b>) or high (<b>HI</b>), will flash</li></ul></li><li>• When any of the alarms above is detected:<ul style="list-style-type: none"><li>– The controller's output Y1 (Y2 for circuit 2) switches to 0 V</li><li>– Relay Q14 (Q24 for circuit 2) will be de-energized</li></ul></li></ul>

## Medium temperature TM

- External capacity control  
DC 0...10 V / 4...20 mA signal from an external controller (Synco, Saphir and other third-party controller) based on the measured medium temperature.  
A measured value of  $\leq -0.5$  V or  $\geq 10.5$  V ( $\leq 3.5$  or 20.5 mA) produces the following effects:
  - The alarm icon  flashes, and the LCD displays **ERR** in place of the actual value of superheat  $\Delta t$ , and the respective range limit indicator, low (**LO**) or high (**HI**), will flash
  - The controller's output Y1 switches to 0 V
  - Relay Q14 will be de-energized
- Internal capacity control with active sensor  
DC 0...10 V / 4...20 mA signal from an external controller (Synco, Saphir and other third-party controller) based on the measured medium temperature.  
A measured value of  $\leq -0.5$  V or  $\geq 10.5$  V ( $\leq 3.5$  or 20.5 mA) produces the following effects:
  - The alarm icon  flashes, and the LCD displays **ERR** in place of the actual value of superheat  $\Delta t$ , and the respective range limit indicator, low (**LO**) or high (**HI**), will flash
  - The controller's output Y1 switches to 0 V.
  - Relay Q14 will be de-energized
- Internal capacity control with passive sensor (or two circuits with passive sensor)
- Signal from a passive temperature sensor Ni1000.  
For any short-circuit or open-circuit detected:
  - The alarm icon  flashes, and the LCD displays FAIL in place of the actual value of superheat  $\Delta t$
- A measured value of  $\leq TL$  or  $\geq 80^\circ\text{C}$  will produce the following effects:
  - The alarm icon  flashes, and the LCD displays **ERR** in place of the actual value of superheat  $\Delta t$ , with the respective range limit indicator, low (**LO**) or high (**HI**), will flash
- When any of the alarms above is detected:
  - The controller's output Y1 (Y2 for circuit 2) switches to 0 V
  - Relay Q14 (Q24 for circuit 2) will be de-energized

## Relay Q14 / Q24 (Alarm relay)

Relay contact Q14 (Q24 for circuit 2) is controlled by the safety functions. Depending on the circuitry, this changeover contact can be used either for actuating a separate alarm horn or for integration in the compressor's safety circuit.

## Forced opening of the valve

In the **simulation mode**, the required valve opening (default value = 0 %) can be entered on the user interface. This is very helpful when filling the plant with refrigerant, for short-time emergency operation, service work, etc.

In this operating mode, the minimum superheat is monitored.

## Important

In the simulation mode, the supervisory functions are active only if the operational status signal D1 (D2 for circuit 2) is present. For safety reasons, the normal control mode is automatically resumed after 15 minutes.



## Mechanical design

### Casing

The RWR462.10 is a compact controller conforming to DIN 43 880 Gr 1, housed in a closed plastic casing.

### Mounting choices

The superheat controller can be mounted in the control panel in one of the following ways:

- In a standard control panel conforming to DIN 43 880
- Wall mounting on top hat rails which are already fitted (EN 60715-TH 35-7.5)
- Wall mounting with two fixing screws
- Flush panel mounting with the help of the ARG462.10 mounting kit

### Connection terminals

Plug-in screw terminals

### Operating and display elements

The RWR462.10 is operated with the operating elements located on the unit front. No aids, such as a PC tool, are required.

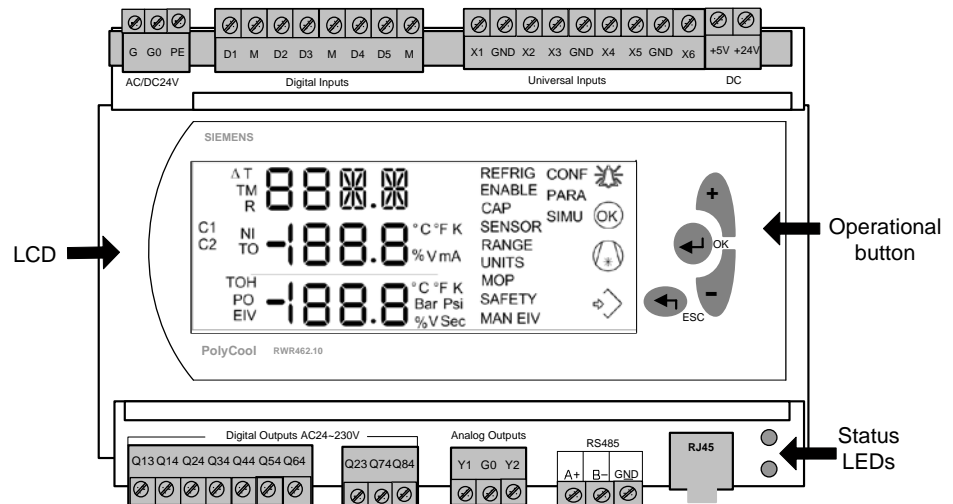

### LCD

The LCD displays:

- The current operational data
- The function code and the icons.

### Icons

- Alarm indicates any fault detected when flashing continuously
- Okay indicates that the system works well when lit
- Compressor indicates the compressor is disabled when flashing
- Communication indicates the controller is communicating with others when lit (not active in this version)

### Status of LEDs

LED red (above) and LED green (below) indicates the controller's operating status.

Status	Meaning
LED green ON	Power on
LED red flashing every 1 second and LED green ON	Alarm

## Operating buttons



To operate the controller, use the operating buttons on the controller front. The operating buttons provide the following functions:

- Use the <OK> button to enable changes or confirm a change.
- Use the +/- buttons to change flashing data, or select the information screen.
- Press the <ESC> to exit out of the current level and back to the previous one.
- By simultaneously pressing the buttons +, -, <ESC> and <OK> for more than 5 seconds the controller gets reset to default settings.

### A flashing display indicates adjustable data.

Reset function may only be carried out with the machine at a standstill.

Important

## Operation

For the configuration and fine tuning of the superheat controller, there are different operating levels and operating modes available.

Selection of operation mode

In normal operation, PolyCool™ is in the **regulation mode**. Follow procedures below to access the operation mode, as appropriate.

Operating modes	Procedures
	In regulation mode, simultaneously press down the + and - buttons for at least five seconds. Press <OK> to confirm when C1 is flashing.
<b>Configuration mode</b> *	Select the mode with +/-, and press <OK> to proceed. Or, press <ESC> to exit out of the current operation level.
<b>Parameter mode</b>	
<b>Simulation mode</b> **	

\* The circuit can only be enabled or disabled in the configuration mode.

\*\* The simulation mode (SIMU) is only applicable to Circuit 1.

If the controller has already been configured, the **regulation mode** will automatically be activated when switching on. From any other mode, the controller will automatically return to the Regulation mode after 15 minutes.

Important

Before accessing the specific operation mode, users are required to specify the circuit. By default, circuit 1 is selected and cannot be disabled.

Exception

If settings in the configuration mode are changed while the controller is in operation (does not apply to units), controller output Y1 (Y2 for circuit 2) will switch to 0 V. In that case, the control will be released again only after all following parameters have been enabled by pressing the <ESC> button on the right (controller must be brought into the Regulation mode).

## Selection of Circuit

Before configuring the controller, you need first specify and enable (if needed) the circuit, C1 or C2, as appropriate. By default, C1 is the working system and cannot be disabled.

Enabling / Disabling the Circuit

After selecting the circuit, go to the configuration mode (CONF) and select the <ENABLE> → <COMP> parameter. Set the parameter value as ON or OFF by pressing +/-.

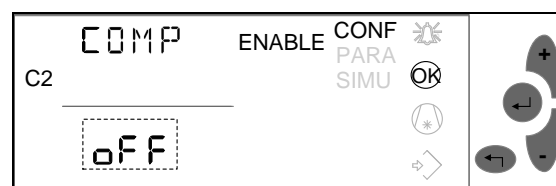

**Configuration mode**  
**[CONF]**

Following the initial power up, the controller automatically enters the configuration mode. In this mode, the type of refrigerant is selected and the unit of temperature °C or °F and pressure Bar or Psi determined.

Notes

Optionally, control of the cooling capacity can be configured.  
 To reconfigure the controller, refer to "Selection of operation mode" above.

Parameter list

Function	Parameter code		Adjustable Range / Increment	Default Value
Selection of refrigerant	<b>REFRIG</b>		R22, R23, R32, R125, R134a, R152a, R170, R227E, R236F, R245F, R290, R401A, R401B, R401C, R402A, R402B, R404A, R406A, R407A, R407B, R407C, R407F, R408A, R409A, R410A, R410B, R413A, R417A, R421A, R422A, R422D, R427A, R434A, R437A, R438A, R502, R507, R600, R600a, R717, R723, R744, R1270	-
Enable / disable compressor and EIV feedback signal	<b>ENABLE</b> <sup>1)</sup>	<b>COMP</b> (compressor)	For circuit 1: ON	ON
			For circuit 2: ON, OFF	OFF
		<b>Fb</b> (EIV feedback)	ON, OFF (only for Circuit1)	OFF
Selection of application	<b>CAP</b> <sup>2)</sup>	(see page 3)	NO (simple superheat) EXT (external capacity control) INT(internal capacity control)	NO
Types of sensors	<b>SENSOR</b>	<b>X1</b>	QBE9103-P10U /-P30U/-P60U with 4...20 mA output signal; QBE2004-P10U /-P25U/-P60U with 0...10 V output signal	QBE9103-P10U
		<b>X2</b>	Ni1000	Ni1000
		<b>X3</b>	0...10 V, 4...20 mA	0...10 V
		<b>X4</b>	For configured internal capacity (Circ. 1): NO, 0...10 V, 4...20 mA; For configured external capacity (Circ. 1): 0...10 V, 4...20 mA; Only for enabled Circuit 2: QBE2004-P10U/-P25U/-P60U with 0...10 V output signal, or QBE9103-P10U/-P30U/-P60U with 4...20 mA output signal	-
		<b>X5</b>	Ni1000	-
Measurement range	<b>RANGE</b> <sup>3)</sup>	<b>X4</b>	<b>LO</b> (low limit): -90.0...90.0 °C / 0.1 °C -130.0...194.0 °F / 0.1 °F	-35.0 °C -31.0 °F
			<b>HI</b> (high limit): -90.0...90.0 °C / 0.1 °C -130.0...194.0 °F / 0.1 °F	+35.0 °C +95.0 °F
Selection of units	<b>UNITS</b>	<b>T</b> (temperature)	°C (K), °F	°C (K)
		<b>P</b> (pressure)	Bar, Psi	Bar
		<b>EIV</b> (valve opening)	V, %	%

1) The compressor of Circuit 1 is the default working unit and cannot be disabled. EIV feedback signal is only available for Circuit 1.

2) Can be parameterized only if external or internal capacity control has been selected in the configuration mode.

3) The range limit (RANGE) can be configured only if internal capacity control (application 3) and X4 have been selected.

 **Important**

**If the wrong type of refrigerant is selected, the plant can be damaged!**

**Parameter mode**  
[PARA]

Adjustment of all setpoint and parameters such as proportional band, integral action time, etc., for the operation safety controls, superheat, capacity controller, and the MOP function. The setpoint of the MOP function must be adjusted as specified by the supplier of the compressor or as demanded by the application.

Parameter list

Function	Parameter	Function code	Default Value	Adjustable Range / Increment
<b>ΔT</b> (Superheat PID-sequence)	Setpoint ΔT (TOH-TO)	<b>SP</b>	6.0 K 10.8 °F	0...25.0 K / 0.1 K 0...44.9 °F / 0.1 °F
	P-band	<b>XP</b>	10 K 18 °F	2...160 K / 1 K 3...288 °F / 1 °F
	Integral action time	<b>TN</b>	30 s	0...600 s (10 min) / 1 s
	D-part	<b>D</b>	0	0...5/1
<b>CAP</b> <sup>1)</sup> (Capacity Control)	Maximum setpoint change with superheat	<b>SMX</b>	18 K 32.4 °F	0...50.0 K / 0.1 K 0...90.0 °F / 0.1 °F
	External signal direction <sup>2)</sup>	<b>SD</b>	+ 1	-1 / +1
	Setpoint of medium temperature TM <sup>3)</sup>	<b>SP</b>	6.0 °C 42.8 °F	-45.0...90.0 °C / 0.1 °C -49.0...194.0 °F / 0.1 °F
	P-band <sup>3)</sup>	<b>XP</b>	35 K 63 °F	2...160 K / 1 K 3...288 °F / 1 °F
	Integral action time <sup>3)</sup>	<b>TN</b>	95 s	0...600 s (10 min) / 1 s
<b>MOP</b>	Max. limitation	<b>SP</b>	15.0 °C 59.0 °F	-45.0...75.0 °C / 0.1 °C -49.0...167.0 °F / 0.1 °F
	P-band	<b>XP</b>	25 K 45 °F	2...160 K / 1 K 3...288 °F / 1 °F
	Integral action time	<b>TN</b>	40 s	0...600 s (10 min) / 1 s
<b>SAFETY</b> <sup>4)</sup> (Operation safety controls)	Valve startup delay time	<b>VD</b> <sup>4)</sup>	0 s	0...60 s / 1 s
	Valve opening time	<b>VT</b> <sup>4)</sup>	1 s	0...30 s / 1 s
	Valve startup opening limit	<b>VO</b> <sup>4)</sup>	0 %	0...50 % / 1 %
	Pressure sensor alarm ignoring time when controller startup	<b>PA</b>	5 s	0...60 s / 1 s
	Low limit for temperature measurement <sup>5)</sup>	<b>TL</b>	-40 °C -40 °F	-70...-40 °C / 1 °C -94...-40 °F / 1 °F
	Minimum superheat ΔT	<b>MI</b>	2 K 3.6 °F	0...4 K 0...7.2 °F

- 1) Can be parameterized only if external or internal capacity control has been selected in the configuration mode.  
 2) SD can be parameterized only if external capacity control has been selected in the configuration mode.  
 SD = 1 means that 0 V / 4 mA corresponds to max. cooling capacity  
 SD = -1 means that 0 V / 4 mA corresponds to min. cooling capacity  
 3) Can be parameterized only if internal capacity control has been configured.  
 4) Operation safety control.  
 5) An alarm will display if the measured temperature value is over this limit.

 **Control algorithm**

The firmware version V1.24B0048 (batch number S130513 or higher) includes a new control algorithm. In order to ensure backward compatibility, please refer to the table below.

Parameter code old	Parameter code new
ΔT XPold	ΔT XPold * 1,25
ΔT TNold	ΔT TNold
ΔT Dold	ΔT Dold
MOP XPold	50 K / MOP XPnew ≤ 1 <sup>1)</sup> 50 K / MOP XPnew ≤ 0,75 <sup>2)</sup>
MOP TNold	MOP TNold

- 1) Recommendation for air coolers "dry" expansion.  
 2) Recommendation for liquid coolers (for example shell-and-tube heat exchangers).

The formulas in the table above provide approximated values for controller settings. Therefore additional fine-tuning is highly recommended.

Example

**Liquid cooler** (shell-and-tube heat exchanger)

Parameter code	old	new
$\Delta T_{XP}$	30 K	30 K * 1,25 = 38 K
$\Delta T_{TN}$	65 s	65 s
MOP XP	20 k	50 K / 20K = 2,5 > 0,75 → 50 K / 0,75 = 67 K or higher
MOP TN	40 s	40 s

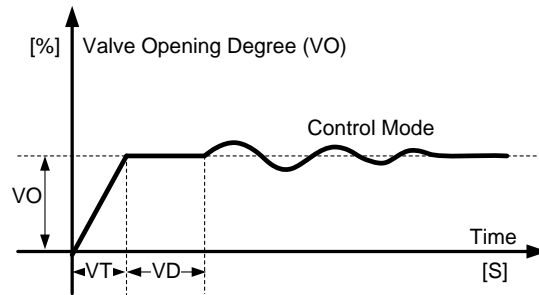

**⚠ Icing**

Capacity control is accomplished by increasing the superheat. For this reason, a reduction in capacity is always associated with a drop in the evaporation temperature. In the case of chillers with no frost protection additives or direct expansion air coolers, there is thus a risk of icing under part load conditions.

**Simulation mode**  
**[SIMU]**

In simulation mode, the valve can be opened for service purposes. The position feedback signal and the values of pressure and temperature can be displayed.

Parameter list

Function	Parameter	Function-Code	Factory setting	Selectable Range / step
Valve	manual valve opening	MAN EIV	0 V	0...10 V / 0.1 V

**⚠ Important**

In simulation mode, the supervisory functions are active only if the operational status signal D1 is present. For safety reasons, the normal control mode is automatically resumed after 15 minutes.

At this mode a variable opening of the electronic injection valve can be enforced. The default value is 5 V, which complies with a valve opening degree of 50 % and allows a manual entering of any value between 0 and 10 V (increment 0.1 V).

Regulation mode

In this mode, all current input and output variables of the superheat and capacity control can be displayed.

## Mounting and Installation notes

---

For mounting and electrical installation, the following notes should be observed.

### Controller

#### A Mounting on DIN rail



No additional parts are required.

#### B Wall mounting

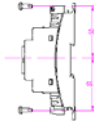

With four ellipse screws for holes with diameter of 4 mm x 6 mm

#### C Flush panel mounting

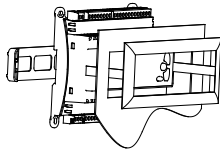

With HVAC Products ARG462.10 mounting kit  
Mounting Instruction M 3351.1

### Electrical installation

The wiring can be made with standard cables. Shielded cables are recommended only if the controller is exposed to strong electromagnetic fields (EMC).



- The PolyCool™ RWR462.10 controller operates on AC / DC 24 V (max. 10 VA) extra low voltage and is short-circuit-proof
- The operating voltage must satisfy the requirements for safety extra low voltage (SELV) conforming to EN 60 730
- The transformers used must be safety transformers with double insulation conforming to EN 60 742. They must be designed for 100 % duty. When using several transformers in the system, terminals G0 must be galvanically interconnected
- If voltages of more than AC 24 V +20 % (DC 24V +10 %) are fed to the low voltage terminals, the controller or other connected devices can be damaged beyond repair. Also, voltages exceeding 42 V represent an electric shock hazard
- Mains voltages up to AC 250 V may only be fed to the potential-free contact Q13

## Connection diagram

Wiring must be made in compliance with the following connection diagram.

**⚠ Please do not connect M with GND!**

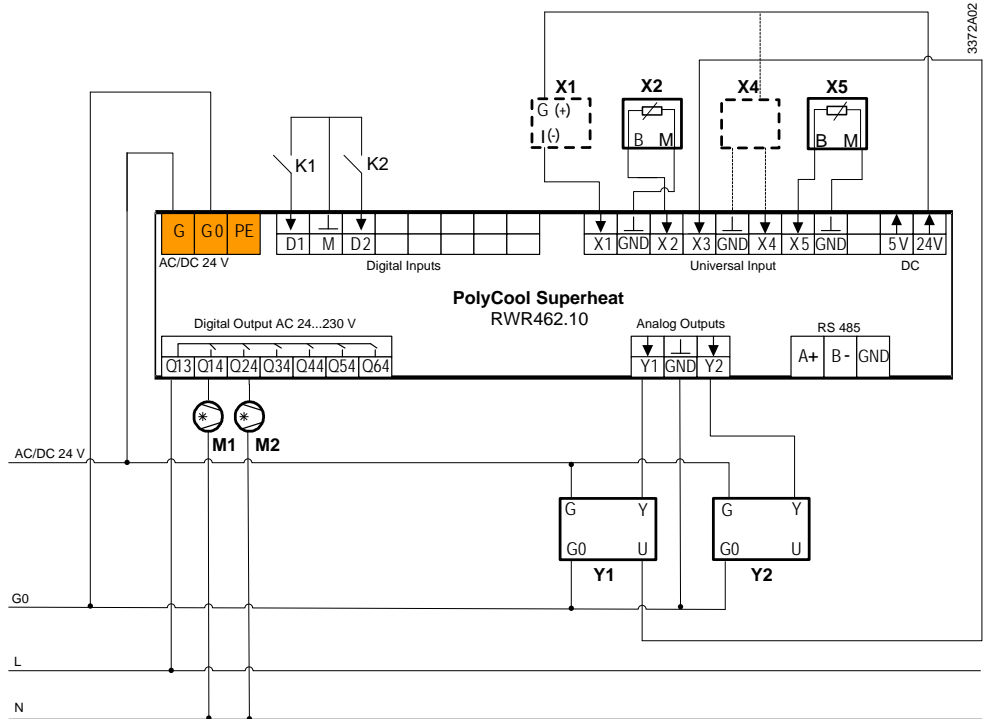

Devices	Terminal Assignments
X1 Pressure sensor e.g. QBE9103-P10U	X1, 24 VDC Evaporation pressure
X2 Temperature sensor QAZ21.682/101	X2, GND Suction gas temperature
X4 Only if capacity control is configured: - Active temperature sensor - Signal transmitter DC 0...10 V / 4...20 mA *	X3 EIV position feedback signal X4, GND For configured capacity control: - External signal DC 0...10 V / 4...20 mA - Medium temperature
For two circuits: Pressure sensor e.g. QBE9103-P10U	For two circuits: - evaporation pressure
X5 Temperature sensor QAZ21.682/101 (only required for capacity control and two circuits)	X5, GND For configured internal capacity control: Medium temperature For two circuits: suction gas temperature
K1 Enable circuit 1	D1, M Enable (for circuit 1)
K2 Enable circuit 2	D2, M Enable (for circuit 2)
M1 Compressor 1 (circuit 1)	Q14, Q13 Compressor 1 (circuit 1)
M2 Compressor 2 (circuit 2)	Q24, Q13 Compressor 2 (circuit 2)
Y1 Electronic injection valve (EIV) e.g. MVL661...-... or MVS661.25-...	Y1 Positioning signal EIV (DC 0...10 V)
Y2 For two circuits: # 2 Electronic injection valve (EIV) e.g. MVL661...-... or MVS661.25-...	Y2 Positioning signal EIV (DC 0...10 V)
	G, G0 Power supply AC/DC 24 V
	5V DC 5 V supply
	24 V DC 24 V supply

\* Usable range: -0.5...10.5 V / 3.5...20.5 mA.  
Outside this range, the controller locks out!

**Connection diagram**

**Pressure sensor with DC 0...10 V signal (X1)**

The following diagram shows example for the wiring of pressure sensor QBE2004 (DC 0...10 V signal) with 3-wire connection (analogue input X1).

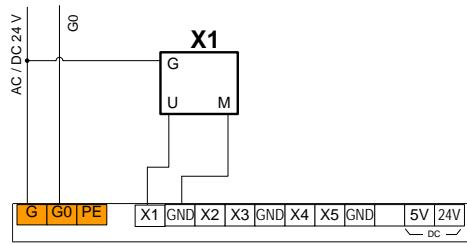

**Connection diagram**

**Active temperature sensors (X4)**

The following diagrams show examples for the wiring of active temperature sensors with 3-wire and 2-wire connections (analogue input X4).

Active temperature sensor with DC 0...10 V or 4...20 mA signal, 3-wire connection

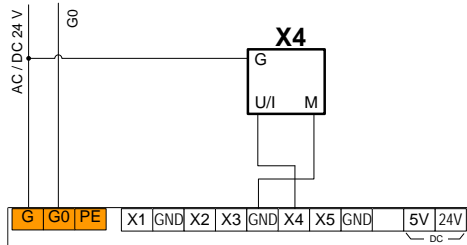

Active temperature sensor with 4...20 mA signal, 2-wire connection

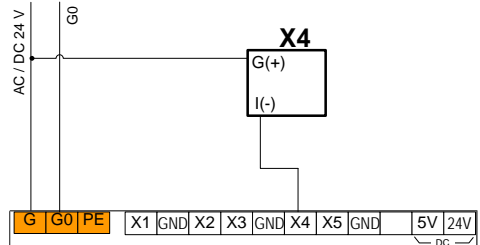

**Commissioning notes**

Required documentation

- To commission the controller, the following pieces of documentation are required:
- The Installation and User Manual CE1U3372XX / H 74 319 0555 0 supplied with the controller
  - The plant connection diagram and all other control documentation kept in the control panel or by the plant operator

Refrigeration data

- To configure the PolyCool™ RWR462.10 control loops and to set the relevant parameters, the following plant data are required:
- Type of refrigerant used (R22, R134a, etc.)
  - Design data of evaporator (superheat, max. evaporation temperature, MOP)

Checking installation of peripheral devices

Before applying power to the controller (AC / DC 24 V), the installation must be checked to make certain it is wired according to the connection diagrams.



## Configuration of DIP Switches

### Configuration of DIP Switches for analogue inputs (X...)

The **default factory settings** of DIP switches at the rear top of the controller are presented as follows. Bit 1 of J2 is used for factory calibration.

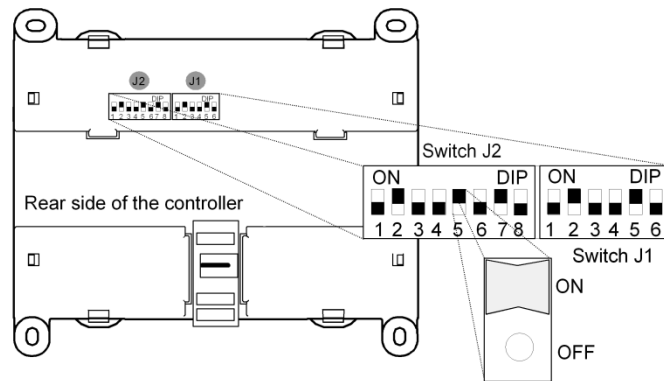

To wire the terminals with different types of sensors, configure the DIP Switches as follows.

#### For X1

	Bit 4 of J1	Bit 5 of J1	Bit 6 of J1	
4...20 mA	Off	On	Off	4...20 mA
0...10 V	On	Off	Off	0...10 V

#### For X2

	Bit 2 of J1	Bit 3 of J1		
Ni1000	On	Off		Ni1000

#### For X3

	Bit 7 of J2	Bit 8 of J2	Bit 1 of J1	
4...20 mA	Off	On	Off	4...20 mA
0...10 V	On	Off	Off	0...10 V

#### For X4

	Bit 4 of J2	Bit 5 of J2	Bit 6 of J2	
4...20 mA	Off	On	Off	4...20 mA
0...10 V	On	Off	Off	0...10 V

#### For X5

	Bit 1 of J2	Bit 2 of J2	Bit 3 of J2	
Ni1000	Off	On	Off	Ni1000

## Configuration and parameter settings

To meet the plant-specific requirements, the controller must be configured by authorized staff that must also set the relevant parameters:

- The project-specific data must be transferred to the controller. The Installation and User Manual contains the step-by-step procedure which must be followed
- During commissioning, fault messages can occur (don't pay attention to them). **On completion of commissioning, fault messages must no longer be present!**
- The values and settings entered on the controller are saved in non-volatile memory even in the event of a power failure.

## Notes

## Selection of refrigerant

When starting up the controller for the first time, the configuration mode appears. First, the correct type of refrigerant and the units must be selected. The types of refrigerant that can be selected are:

R22	R23	R32	R125	R134a	R152a	R170*	R227ea <sup>1)</sup>
R236fa <sup>2)</sup>	R245fa <sup>3)</sup>	R290*	R401A	R401B	R401C	R402A	R402B
R404A	R406A	R407A	R407B	R407C	R407F	R408A	R409A
R410A	R410B	R413A	R417A	R421A	R422A	R422D	R427A
R434A	R437A	R438A	R502	R507	R600*	R600a*	R717**
R723	R744	R1270*					

- 1) Displayed as R227E
- 2) Displayed as R236F
- 3) Displayed as R245F

### Important

- \* Hydrocarbons: Can only be used for explosion-proof valves!
- \*\* R717 (NH3): Requires the use of valves suited for ammonia, e.g. MVS661.25-...

**If the wrong type of refrigerant is selected, the plant can be damaged!**

## Selection of units

The temperature can be displayed in °C (**K**) or °F, and the pressure in **Bar** or **Psi**.

## Selection of application

Configurable are (also refer to pages 3 and 4):

- Default: simple superheat control
- External capacity control
- Internal capacity control
- Two superheat circuits, if circuit 2 is enabled.

### Icing

Refer to page 11 (Parameter mode / Parameter list)

## Checking the peripheral devices

Before switching the refrigeration plant on, the peripheral devices should be checked:

- Temperature and pressure sensors  
The suction gas temperature TOH, the evaporation pressure P0, the evaporation temperature TO and in accordance with the configuration, the medium temperature TM are displayed in the control mode.
- Electronic injection valve  
In the simulation mode, the degree of opening (MAN EIV) of the electronic injection valve can be preset. Also, it is possible to check whether the valve's actual position (EIV) agrees with the manually preset position (MAN EIV)
- When the wiring of the plant and all peripheral devices are in order, the plant can be switched on.

The factory-set parameters for superheat control (XP, TN and D), the MOP function and the capacity control (XP and TN) are values gained from practical experience. The Installation and User Manual contains detailed information about how the controller can be fine-tuned to achieve optimum performance.

## Fault status signals

Should faults or malfunctions on the controller, valve or sensors occur, the alarm  icon will flash and the LCD displays ERR or FAIL in place of the corresponding parameter. The following list shows the possible causes and how the faults can be rectified:

Component	Fault	Possible cause
Passive temperature sensor Ni1000	Measured value flashes Display: FAIL	Sensor cable with an open-circuit / not connected, or a short-circuit
	Measured value flashes Display: ERR / LO	Measured value $\leq$ TL
	Measured value flashes Display: ERR / HI	Measured value $\geq$ 80°C
Active temperature sensor with DC 0...10 V / 4...20 mA or other DC 0...10 V / 4...20 mA signal transmitters (Synco, Saphir and other third-party controller)	Measured value flashes Display: ERR / LO	Measured value $\leq$ -0.5 V or 3.5 mA (in external capacity control) Measured value $\leq$ 0 V or 4 mA (in internal capacity control with active temperature sensor)
	Measured value flashes Display: ERR / HI	Measured value $\geq$ 10.5 V or 20.5 mA (in external capacity control) Measured value $\geq$ 10 V or 20 mA (in internal capacity control with active temperature sensor)
Pressure sensor	Measured value flashes Display: ERR/ LO	Measured value $\leq$ 0 V or 4 mA (depending on the type of pressure sensor)
	Measured value flashes Display: ERR / HI	Measured value $\geq$ 10 V or 20 mA (depending on the type of pressure sensor)
Electronic injection valve (EIV)	No position feedback signal = 0 V	Connecting cable for feedback signal with an open-circuit / not connected
	Valve does not open	Connecting cable not connected
		In the simulation mode, the valve can be checked by manually entering the degree of opening and by comparing it with the position check back signal
		Valve faulty
	Position feedback signal does not match the manually entered degree of opening	Cable for feedback signal not connected (for connection terminals, refer to data sheet) Open-circuit or valve faulty
Controller	No display	Check power supply (AC / DC 24 V)
	Manipulated variable always 0 V (Y1)	Short-circuit / sensor with open-circuit No enabling via D1 * (D2 for circuit2) Controller faulty
	Icing of evaporator with no enabling via D1(D2 for circuit 2)	Controller output Y1 is not 0 V $\Rightarrow$ Controller faulty
		External noise voltage on the signal line to the EIV

\* For any faults about the enabling signal D1 / D2, the compressor icon  will flash simultaneously.

## Disposal notes



The devices are considered electronics devices for disposal in term of European Directive 2012/19/EU and may not be disposed of as domestic waste.

- Dispose of the device via the channels provided for this purpose
- Comply with all local and currently applicable laws and regulations.

## Technical data

⚠ Power supply	Operating voltage	AC 24 V ± 20 % (DC 24 V ± 10 %)
	Safety extra low voltage (SELV) to	EN 60 730-1
	Frequency	50 Hz / 60 Hz
Power consumption	RWR462.10	approx. 10 VA (with full configuration)
Interrogation rate	Cycle time Y1	0.5 s
	Cycle time Y1 and Y2 together	0.5 s
Display (LCD)	Actual values and setpoints	4 digits
	Resolution	0.1
	Analog outputs (DC 0...10 V)	2 digits, resolution 0.1 V / 1 %
	Digital switching outputs	off / on
Environmental conditions	Transport	IEC 60721-3-2, Class 2K3
	Temperature range	-25°C...70 °C
	Humidity	< 95 % r.h.
	Mechanical conditions	Class 2M2
	Operation	IEC 60721-3-3, Class 3K5
	Temperature	-5 °C...50 °C
Humidity	< 95 % r.h. non-condensing	
Storage temperature	-20°C...70°C	
Degree of contamination	Normal contamination	EN 60 730-1
Degree of protection	Casing	IP 20 to EN 60 529
	Front	IP 40 to EN 60 529
Product standards	Energy management equipment	UL 916
Quality assurance	Production and customer service	to ISO 9001
Norms and standards	EU Conformity (CE)	CE1T3372xx *)
	RCM conformity	CE1T3372en_C1 *)
*) The documents can be downloaded from <a href="http://siemens.com/bt/download">http://siemens.com/bt/download</a> .		
Connection terminals	Plug-in screw terminals for	
	Wires	min. 0.75 mm <sup>2</sup>
	Number of wires x wire gage	2 x 1.5 mm <sup>2</sup> or 1 x 2.5 mm <sup>2</sup>
Analog inputs X1...X5	Measurement values	
	<b>X1</b> Pressure sensor	DC 0...10 V / 4...20 mA
	<b>X2</b> Temperature sensor LG-Ni 1000	°C
	<b>X3</b> Position feedback signal valve	DC 0...10 V / 4...20 mA
	<b>X4*</b> Medium temperature	DC 0...10 V / 4...20 mA
	<b>X4*</b> External signal	DC 0...10 V / 4...20 mA
	<b>X4*</b> Pressure sensor (for circuit 2)	DC 0...10 V / 4...20 mA
<b>X5</b> Temperature sensor LG-Ni 1000	°C	
*X4 According to the configuration		

Signal 0...10 V	Range	DC 0...10 V
	Under- and over- range	-1.4...11.4 V
	Resolution	10 mV
	Accuracy of RWR462.10	0.078 V
	Max. current drawn	0.98 mA
	Internal resistance $R_i$	> 10 k $\Omega$
Signal 4...20 mA	Range	DC 4...20 mA
	Under- and over- range	-3...24 mA
	Resolution	0.02 mA
	Accuracy of RWR462.10	0.3 mA
	Max. current drawn	24 mA
	Internal resistance $R_i$	240 $\Omega$
Temperature signal	Range	-50...80 °C
	Under- and over- range	-60...110 °C
	Resolution	< 0.23 K at 0 °C
	Accuracy of RWR462.10	$\pm$ 0.5 K at 20 °C
	Measuring voltage	max. DC 5.0 V
	Measuring current	1.84...2.36 mA
Digital inputs D1, D2	Switching contacts	potential-free
	Current (from the controller)	$\geq$ 8 mA
Analog outputs Y1, Y2	Voltage modulated (VM), range	DC 0...10 V
	Under- and over- range	DC -1.4...11.4 V
	Resolution	39 mV
	Current	max. 10 mA
<b>Cable length</b>		
Analog signals	Max. permissible cable length	300 m, also refer to specification of connected unit
	For 0.75 mm <sup>2</sup>	
Digital signals	Max. permissible cable length	300 m
	For 0.75 mm <sup>2</sup>	
Temperature signals	Max. permissible cable length	100 m (total line resistance of 5.5 $\Omega$ corresponds to an error of approx. 1 °C)
	For 0.75 mm <sup>2</sup>	

Relay outputs Q14, Q24	Switching capacity of relay contact Q14, Q24	
	Alternating current	AC 24...230 V, 3 A res., 2 A ind.
	Direct current	max. DC 30 V, max. 5 A
	Min. contact rating	
	At mains voltage	AC 230 V / 5 mA
	At low voltage	DC 24 V / 10 mA
	Max. starting current	7.5 A (1 s)
	External fuse on input side	max. 10 A
	Min. Load	100 mA at DC 5 V
	Initial contact resistance	100 M $\Omega$ at 1 A, 6 VDC
	Max. Switching Rate	300 ops./min. (no load) 20 ops./min. (rated load)
	Life of relay contacts	
	AC at 0.1 A res.	2 x 10 <sup>6</sup> cycles
	at 0.5 A res.	4 x 10 <sup>5</sup> cycles
	at 3 A res.	1 x 10 <sup>5</sup> cycles
	Red. factor with ind. loads	0.85 (cos.phi = 0.8)
	DC	1 x 10 <sup>5</sup> cycles
	Expected mechanical life	5 million ops (no load)
	Expected electrical life	100,000 ops (rated load)
	Insulating strength	
	Between relay outputs and low voltage (SELV)	AC 3750 V, to EN 60 730-1
	Between relay outputs and adjacent relays	AC 3750 V, to EN 60 730-1
Weight (excl. Packing)	Controller excl. terminals	0.334 kg
	incl. terminals	0.396 kg

## Dimensions

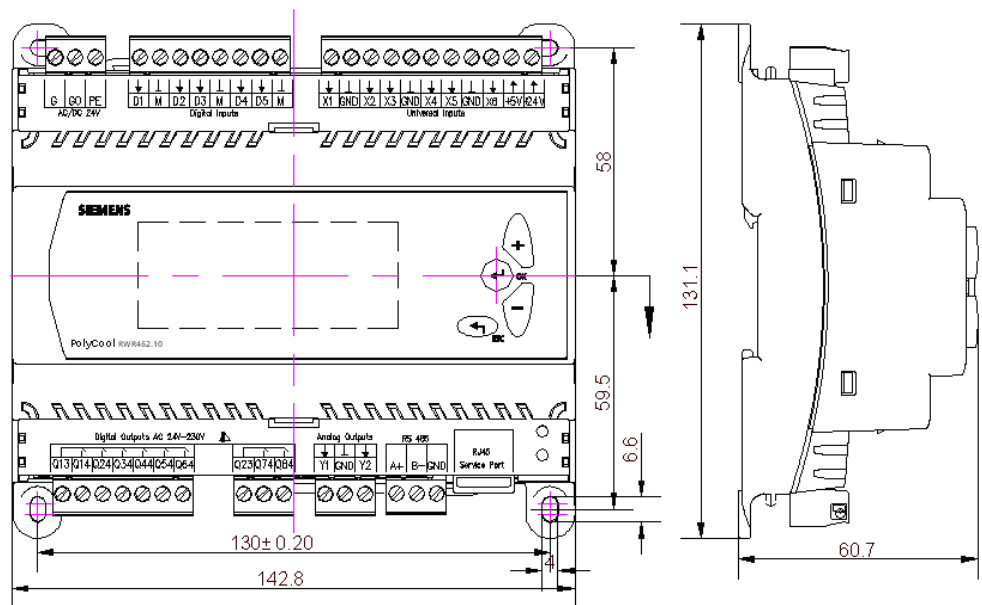

## Index

Analog inputs X1...X5 .....	20	Mechanical design .....	9
Analog outputs Y1, Y2.....	21	Medium temperature TM.....	8
Auxiliary functions.....	2	Mounting and Installation notes .....	14
Casing .....	9	Operating and display elements .....	9
Checking the peripheral devices ...	18	Operating buttons.....	10
Commissioning notes .....	16	Operating safety .....	7
Config. and parameter settings .....	17	Operation.....	10
Configurable functions.....	3	Parameter mode [PARA].....	12
Configuration mode [CONF].....	11	Peripheral devices.....	3
Configuration of DIP Switches.....	17	Protective functions compressor .....	7
Connection diagram .....	15	Relay .....	8
Digital input.....	7	Relay outputs Q14, Q24.....	22
Digital inputs D1, D2.....	21	Selection of application .....	4
Dimensions .....	23	Selection of Circuit .....	10
Electrical installation .....	14	Selection of refrigerant .....	3, 18
Enable .....	7	Selection of units .....	3
Evaporation pressure P0.....	7	Simulation mode [SIMU] .....	13
External capacity control .....	6	Standard functions .....	7
Fault status signals.....	19	Suction gas temperature TOH .....	7
Forced opening of the valve .....	8	Superheat control .....	5
Icing .....	13	Technical data .....	20
Internal capacity control .....	6	Use .....	2