



Oil Burner Controls

LMO64...

Microcontroller-based oil burner controls for the startup, supervision and control of forced draft oil burners in intermittent operation. Maximum oil throughput up to 30 kg/h.

The LMO64 and this Data Sheet are intended for use by OEMs which integrate the burner controls in their products.

Use, features

Use	<p>The LMO64 burner controls are designed for the startup and supervision of 1-stage forced draft oil burners in intermittent operation. Yellow-burning flames are supervised with photo resistive detectors QRB1 / QRB3 or yellow flame detector QRB4, blue-burning flames with blue flame detector QRC.</p> <ul style="list-style-type: none"> • Applications in accordance with EN 267: Automatic forced draft burners for liquid fuels • Type-tested and approved in accordance with DIN EN 298
General features	<ul style="list-style-type: none"> • Undervoltage detection • Electrical remote reset • Bridging contact for oil preheater • Monitoring of time for oil preheater • Accurate and reproducible program sequence through digital signal handling • Controlled intermittent operation after 24 hours of continuous operation • Limitation of the number of repetitions • Multicolor indication of fault and status messages
Specific features	<ul style="list-style-type: none"> • Postpurge function for clearing the combustion chamber after burner operation

Supplementary documentation

Product type	Type of documentation	Documentation number
LMO	Environmental declaration	E7130
ACS410	Software documentation	J7352
OCI400	Data sheet	N7614
QRB1 / QRB3	Data sheet	N7714
QRB4	Data sheet	N7720
QRC1	Data sheet	N7716

Warning notes



To avoid injury to persons, damage to property or the environment, the following warning notes must be observed!

Do not open, interfere with or modify the unit!

- All activities (mounting, installation and service work, etc.) must be performed by qualified staff
- Before making any wiring changes in the connection area, completely isolate the plant from mains supply (all-polar disconnection). Ensure that the plant cannot be inadvertently switched on again and that it is indeed dead. If not observed, there is a risk of electric shock hazard
- Ensure protection against electric shock hazard by providing adequate protection for the burner control's connection terminals. If not observed, there will be a risk of electric shock
- Each time work has been carried out (mounting, installation, service work, etc.), check to ensure that wiring is in an orderly state and make the safety checks as described in «Commissioning notes». If not observed, the safety functions are no longer ensured and there will be a risk of electric shock
- Press the lockout reset button / operation button of the LMO64 only manually (applying a force of no more than 10 N), without using any tools or pointed objects. If not observed, the safety functions are no longer ensured and there will be a risk of electric shock
- Fall or shock can adversely affect the safety functions. Such units must not be put into operation, even if they do not exhibit any damage. If not observed, the safety functions are no longer ensured and there will be a risk of electric shock

Mounting notes

Ensure that the relevant national safety regulations are complied with.

Installation notes

- Always run the high-voltage ignition cables separately while observing the greatest possible distances to the unit and to other cables
- Install switches, fuses, earthing, etc., in compliance with local regulations
- Ensure that the maximum permissible amperages will not be exceeded (refer to «Technical data»)
- Do not feed external mains voltage to the control outputs of the unit. When testing the devices controlled by the burner control (fuel valves, etc.), the LMO64 must never be plugged in
- Do not mix up live and neutral conductors



Attention!

To ensure that the LMO64 does not get mixed up with other types of burner controls, it may only be used in connection with the grey AGK11.6 plug-in base. In particular, it must be made certain that the line for the control thermostat or pressurestat «R» is picked up after the limit thermostat and pressure switch «W» and safety limit thermostat «SB», to be connected to terminal 7 (refer to «Connection diagram»).

Electrical connection of the flame detector

It is important to achieve practically disturbance- and loss-free signal transmission:

- Never run the detector cable together with other cables
 - Line capacitance reduces the magnitude of the flame signal
 - Use a separate cable
- Note the maximum permissible detector cable lengths (refer to «Technical data»)
- Earth the burner in compliance with the relevant regulations; earthing the boiler alone does not suffice

Commissioning notes

When commissioning the plant or when doing maintenance work, make the following safety checks:

	Safety check	Anticipated response
a)	Burner startup with flame detector darkened	Non-alterable lockout at the end of the safety time (TSA)
b)	Burner startup with flame detector exposed to extraneous light	Non-alterable lockout within 40 seconds
c)	Burner operation with simulated flame failure; for that purpose, darken the flame detector during operation and maintain that status	Repetition followed by the non-alterable lockout at the end of safety time (TSA)



Applied directives:

- Low-voltage directive 2014/35/EC
- Directive for pressure devices 2014/68/EC
- Electromagnetic compatibility EMC (immunity) *) 2014/30/EC

*) The compliance with EMC emission requirements must be checked after the burner control is installed in equipment

Compliance with the regulations of the applied directives is verified by the adherence to the following standards / regulations:

- Automatic burner control systems for burners and appliances burning gaseous or liquid fuels DIN EN 298
- Safety and control devices for burners and appliances burning gaseous and/or liquid fuels — General requirements DIN EN 13611
- Automatic electrical controls for household and similar use Part 2-5: Particular requirements for automatic electrical burner control systems DIN EN 60730-2-5

The relevant valid edition of the standards can be found in the declaration of conformity!



Note on **DIN EN 60335-2-102**

Household and similar electrical appliances - Safety - Part 2-102:

Particular requirements for gas, oil and solid-fuel burning appliances having electrical connections. The electrical connections of the LMO64 and the AGK11 comply with the requirements of EN 60335-2-102.



EAC Conformity mark (Eurasian Conformity mark)



ISO 9001:2015
ISO 14001:2015
OHSAS 18001:2007



China RoHS
Hazardous substances table:
<http://www.siemens.com/download?A6V10883536>



Service notes

The service adapters can only be used for a short time. They may only be used in supervised operation by qualified staff.

Life cycle

Burner controls has a designed lifetime* of 250,000 burner startup cycles which, under normal operating conditions in heating mode, correspond to approx. 10 years of usage (starting from the production date given on the type field).

This lifetime is based on the endurance tests specified in standard EN 298.

A summary of the conditions has been published by the European Control Manufacturers Association (Afecor) (www.afecor.org).

The designed lifetime is based on use of the burner controls according to the manufacturer's Data Sheet. After reaching the designed lifetime in terms of the number of burner startup cycles, or the respective time of usage, the burner control is to be replaced by authorized personnel.

* The designed lifetime is not the warranty time specified in the Terms of Delivery

Disposal notes

The unit contains electrical and electronic components and must not be disposed of together with domestic waste.

Local and currently valid legislation must be observed.

Mechanical design

The housing is made of impact-proof, heat-resistant and flame-retarding plastic.

It is of plug-in design and engages audibly in the base.

Burner controls type LMO64 and AGK11.6 plug-in bases are silver-grey (RAL7001).

The housing accommodates the

- microcontroller, which controls the program sequence, and the print relays for load control,
- electronic flame signal amplifier,
- lockout reset button with its integrated multicolor signal lamp for status and fault messages and the socket for connecting the OCI400 interface

Display and diagnostics

- Multicolor display of status and fault messages
- Transmission of status and fault messages as well as detailed service information by additional OCI400 interface and PC software ACS410

Type summary

Article no.	Type reference	Mains voltage	Fuel valve stages	Burner capacity	1)	Remote reset	Times					
							tw max.	t1 / t1' min.	TSA max.	t3 min.	t3n max.	t8 max.
BPZ:LMO64.300C2	LMO64.300C2	AC 230 V	1	<30 kg/h	•	•	2.5 s	15 / 16 s	10 s	15 s	10 s	20 s
BPZ:LMO64.301C2	LMO64.301C2	AC 230 V	1	<30 kg/h	•	•	2.5 s	15 / 16 s	10 s	15 s	10 s	90 s
BPZ:LMO64.302C2 *	LMO64.302C2 *	AC 230 V	1	<30 kg/h	•	•	2.5 s	15 / 16 s	10 s	15 s	3 s	20 s

* On request only!

Legend

- TSA Ignition safety time
- tw Waiting time
- t1 Prepurge time
- t1' Purge time
- t3 Preignition time
- t3n Postignition time
- t8 Postpurge time
- 1) Bridging contact for oil preheater

Test adapter (to be ordered separately)

Test adapter **KF8833**

Article no.: **BPZ:KF8833**

- For checking the functions of burner controls on the burner
- With signal lamps for program indication
- With one pair of jacks for measuring the flame detector current



Test adapter **KF8840**

Article no.: **BPZ:KF8840**

- For checking the functions of burner controls on the burner
- With signal lamps for program indication
- With on / off switch for simulating the flame signal
- With holes for checking the control voltages at the tabs of the burner control
- With one pair of jacks for measuring the flame detector's resistance

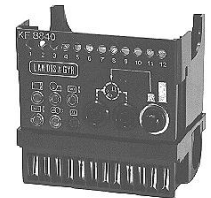

Test adapter **KF8885**

Article no.: **BPZ:KF8885**

- For checking the functions of burner controls on the burner
- With switch for manual startup of the burner
- With switch for simulating the oil preheater's release contact
- With 2 pairs of jacks for measuring the flame detector current



See operating instructions B7986.

Accessories (to be ordered separately)

Connection accessories for small burner controls

Plug-in base **AGK11.6**
Article no.: **BPZ:AGK11.6**
Plug-in base grey for connecting the LMO64 to burner plant.
Refer to Data Sheet N7201.



Cable holders **AGK66**
Article no.: **BPZ:AGK66**
For plug-in base AGK11.
Refer to Data Sheet N7201.



Cable holders **AGK65**
Article no.: **BPZ:AGK65**
For plug-in base AGK11.
Refer to Data Sheet N7201.



Flame detectors

Photo resistive detectors **QRB1**
Refer to Data Sheet N7714.



Photo resistive detectors **QRB3**
Refer to Data Sheet N7714.



Yellow flame detector **QRB4**
Refer to Data Sheet N7720.



Blue-flame detectors **QRC1**
Refer to Data Sheet N7716.

Frontal illumination



Lateral illumination



Accessories (to be ordered separately)

Service-Tools

Optical Interface **OCI400**

Article no.: **BPZ:OCI400**

- Optical interface between burner control and PC
- Facilitates viewing and recording setting parameters on site in connection with the ACS410 PC software

Refer to Data Sheet N7614.



PC software **ACS410**

Article no.: **BPZ:ACS410**

PC software for setting the parameters and for visualizing the burner controls.

Refer to Software Documentation J7352.

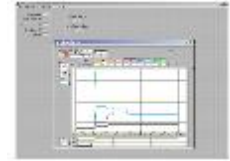

Technical data

General unit data	Mains voltage	AC 230 V +10 % / -15 %
	Mains frequency	50...60 Hz ±6 %
	External primary fuse (Si)	6.3 A (slow)
	Power consumption	12 VA
	Perm. mounting position	Optional
	Weight	Approx. 200 g
	Safety class	I (burner control with plug-in base)
	Degree of protection	IP40 (to be ensured through mounting)
	Perm. cable lengths	Max. 3 m at a line capacitance of 100 pF/m
	From terminal 7 to control thermostat or pressurestat «R»	Max. 20 m at 100 pF/m
	Cable lengths	
	• QRB1 / QRB3	Max. 10 m at 100 pF/m (laid separately)
	• QRB4	Max. 3 m at 100 pF/m (laid separately)
	• QRC	Max. 10 m at 100 pF/m (laid separately)
	Remote reset laid separately	Max. 20 m

Perm. amperage at $\cos \varphi \geq 0.6$	LMO64
Terminal 1	Max. 5 A
Terminals 3 and 8	Max. 3 A
Terminals 4, 5, 6 and 10	Max. 1 A

Environmental conditions

Storage	DIN EN 60721-3-1
Climatic conditions	Class 1K3
Mechanical conditions	Class 1M2
Temperature range	-20...+60 °C
Humidity	<95 % r.h.
Transport	DIN EN 60721-3-2
Climatic conditions	Class 2K2
Mechanical conditions	Class 2M2
Temperature range	-20...+60 °C
Humidity	<95 % r.h.
Operation	DIN EN 60721-3-3
Climatic conditions	Class 3K3
Mechanical conditions	Class 3M3
Temperature range	-5...+60 °C
Humidity	<95 % r.h.
Installation altitude	Max. 2,000 m above sea level



Attention!

Condensation, formation of ice and ingress of water are not permitted! If not observed, the safety functions are no longer ensured and there will be a risk of electric shock.

Technical data (cont'd)

Flame supervision with QRB and QRC

	Required detector current (with flame)	Perm. detector current (without flame)	Possible detector current with flame (typically)
QRB1 ¹⁾	Min. 45 μ A	Max. 5,5 μ A	100 μ A
QRB3 ¹⁾	Min. 45 μ A	Max. 5,5 μ A	100 μ A
QRB4 ¹⁾	Min. 45 μ A	Max. 5,5 μ A	70 μ A
QRC ¹⁾	Min. 45 μ A	Max. 5,5 μ A	70 μ A

- ¹⁾ The values given in the table above only apply under the following conditions:
- Mains voltage depending on execution AC 230 V
 - Ambient temperature 23 °C

Green signal lamp (LED) for indication of operating state

	Detector current in operation: - Flame signal instable - Green signal lamp (LED) flashing	Detector current in operation: - Flame signal stable - Green signal lamp (LED) steady on
QRB ¹⁾	<45 μ A	>45 μ A
QRC ¹⁾	<45 μ A	>45 μ A

- ¹⁾ The values given in the table above only apply under the following conditions:
- Mains voltage depending on execution AC 230 V
 - Ambient temperature 23 °C

Measurement circuit for detector current

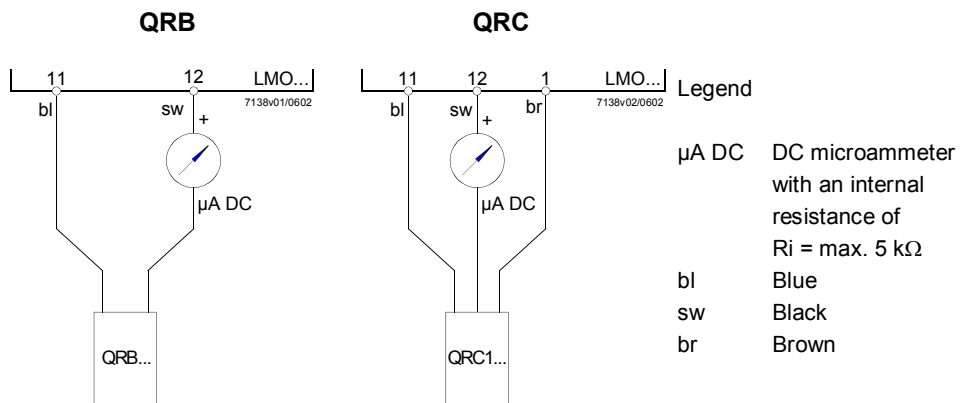

As an alternative to detector current measurement, the OCI400 interface with ACS410 PC software can be used. In that case, connection of the DC microammeter is not required.



Note!

QRB4 cable connection!

Connect the blue QRB4 cable to terminal 11.
Connect the black QRB4 cable to terminal 12.
Otherwise the QRB4 will not function.

Function

Preconditions for startup	<ul style="list-style-type: none"> • Burner control is reset • Reset button «EK1» or «EK2» not used • All contacts in the line are closed, heat demand • No undervoltage • Flame detector is darkened and there is no extraneous light
Undervoltage	<ul style="list-style-type: none"> • Safety shutdown from the operating position takes place should mains voltage drop below about AC 165 V (with $U_N = AC 230 V$) • Restart is initiated when mains voltage exceeds about AC 175 V (with $U_N = AC 230 V$)
Time supervision oil preheater	If the oil preheater's release contact does not close within 10 minutes, a non-alterable lockout takes place.
Controlled intermittent operation	After 24 hours of continuous operation at the latest, the burner control will initiate automatic safety shutdown followed by a restart.
Control sequence in the event of fault	<p>If a non-alterable lockout occurs, the outputs for the fuel valves, the burner motor and the ignition equipment are always immediately deactivated (<1 second).</p> <p>In the event of a non-alterable lockout, the LMO64 remains locked and the red signal lamp (LED) lights up permanently.</p> <p>The burner control can immediately be reset.</p> <p>This status is also maintained in the case of a mains failure.</p>

Cause	Response
Mains failure	Restart
Voltage below undervoltage threshold	Safety shutdown, followed by restart
Extraneous light during «t1», 5 s before «BV1» release	Non-alterable lockout at the end of the prepurge time (t1)
Extraneous light during «tw»	Start prevention, a non-alterable lockout occurs after a maximum of 40 seconds
No flame at the end of «TSA»	Non-alterable lockout at the end of the safety time (TSA), blink code 2, see <i>Control sequence</i>
Flame is lost during operation	Maximum of 3 repetitions, then a non-alterable lockout occurs
Oil preheater's release contact does not close within 10 min.	Non-alterable lockout

Resetting the burner control	<p>After a non-alterable lockout, a reset can be carried out immediately.</p> <p>To do this, press the lockout reset button for about 1 second (<3 seconds). The LMO64 can only be reset when all contacts in the line are closed and when there is no undervoltage.</p>
Ignition program with LMO 64.302	If the flame is lost during the safety time (TSA), the burner will be reignited before the end of the safety time (TSA) at the latest. This means that several ignition attempts can be made within the safety time (TSA), see <i>Program sequence</i> .
Limitation of repetitions	If the flame is lost during operation, a maximum of 3 repetitions can be carried out. Each time the flame is lost during operation, a non-alterable lockout will be initiated. The repetition count is restarted each time controlled switching on by «R» takes place.
Postpurging	<p>Postpurging is only possible when the oil preheater contact is closed or when the wire link between terminals 3 and 8 is fitted.</p> <p>A demand for heat via «R» during postpurge time «t8», implicates an interruption of postpurging, followed by new start.</p>

Operation, display, diagnostics

Operation

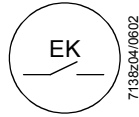

Lockout reset button «EK» is the key operating element for resetting the burner control and for activating / deactivating the diagnostic functions.

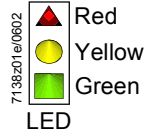

The multicolor signal lamp (LED) in the lockout reset button is the key indicating element for visual diagnostics and interface diagnostics.

Both elements (EK / LED) are located under the transparent cover of the lockout reset button.

There are 2 diagnostic choices available:

1. Visual diagnostics: Operating state indication or diagnostics of the cause of fault
2. Interface diagnostics: With the help of the OCI400 interface and PC software ACS410 or flue gas analyzers of different makes.

Visual diagnostics:

In normal operation, the different operating states are indicated in the form of color codes according to the color code table.

Operating state indication

During startup, indication of the operating state takes place according to the following table:

Color code table for multicolor «LED» signal lamp		
State	Color code	Color
Waiting time «tw», standby on continuous phase, waiting status	○.....	Off
Oil preheater heats	●.....	Yellow
Ignition phase, ignition controlled	○●○●○●○●○●○	Flashing yellow
Operation, flame o.k.	■.....	Green
Operation, flame not o.k. (when detector current drops below the recommended level for reliable operation)	○■○■○■○■○■○	Flashing green
Extraneous light on burner startup	■▲■▲■▲■▲■▲■▲	Green-red
Undervoltage	●▲●▲●▲●▲●▲●▲	Yellow-red
Fault, alarm	▲.....	Red
Output of fault code (refer to «Error code table»)	○▲○▲○▲○▲○▲○	Flashing red
Interface diagnostics	▲▲▲▲▲▲▲▲▲▲▲▲▲▲	Red flicker light

Legend

- Steady on
- Off
- ▲ Red
- Yellow
- Green

Operation, display, diagnostics (cont'd)

Diagnostics of cause of fault

After lockout, the red fault signal lamp remains steady on. In that condition, the visual diagnostics of the cause of fault according to the error code table can be activated by pressing the lockout reset button for more than 3 seconds. Pressing the reset button again for at least 3 seconds, the interface diagnostics will be activated. If, by accident, interface diagnostics has been activated, in which case the slightly red light of the signal lamp flickers, it can be deactivated by pressing again the lockout reset button for at least 3 seconds. The moment of switching over is indicated by a yellow light pulse.

The following sequence activates the diagnostics of the cause of fault:

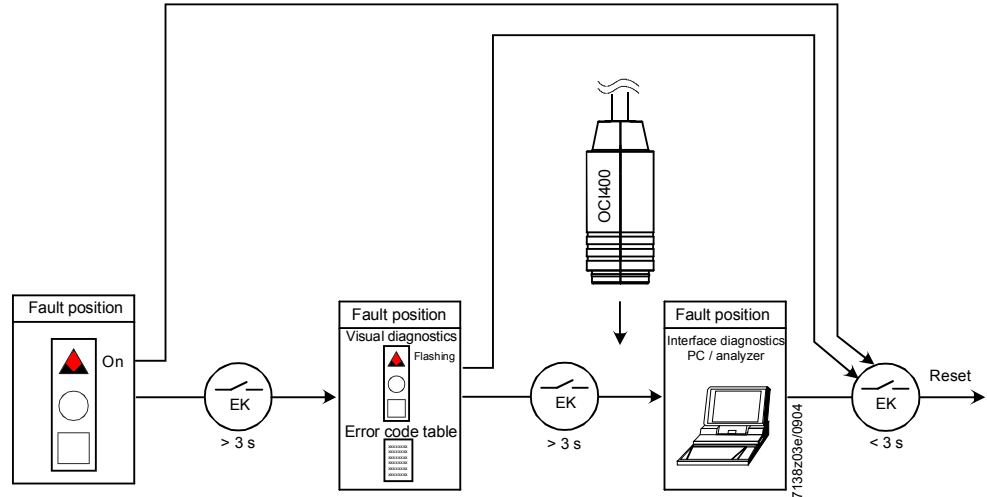

Error code table of multicolor signal lamp

Blink code «red» of signal lamp	Alarm at terminal 10	Possible cause
2 blinks	On	No establishment of flame at the end of «TSA» - Faulty or soiled fuel valves - Faulty or soiled flame detector - Poor adjustment of burner, no fuel - Faulty ignition equipment
3 blinks	On	Free
4 blinks	On	Extraneous light on burner startup
5 blinks	On	Free
6 blinks	On	Free
7 blinks	On	Too many losses of flame during operation (limitation of the number of repetitions) - Faulty or soiled fuel valves - Faulty or soiled flame detector - Poor adjustment of burner
8 blinks	On	Timer supervision oil preheater
9 blinks	On	Free
10 blinks	Off	Wiring fault or internal fault, output contacts, faults that cannot be detected, such as simultaneous faults, other faults

During the time the cause of fault is diagnosed, the control outputs are deactivated

- Burner remains shut down
- the external fault indicator remains de-energized
- Fault status signal (Alarm) at terminal 10, according to the error code table

The diagnostics of the cause of fault is quit and the burner switched on again by resetting the burner control. Press lockout reset button for about 1 second (<3 seconds).

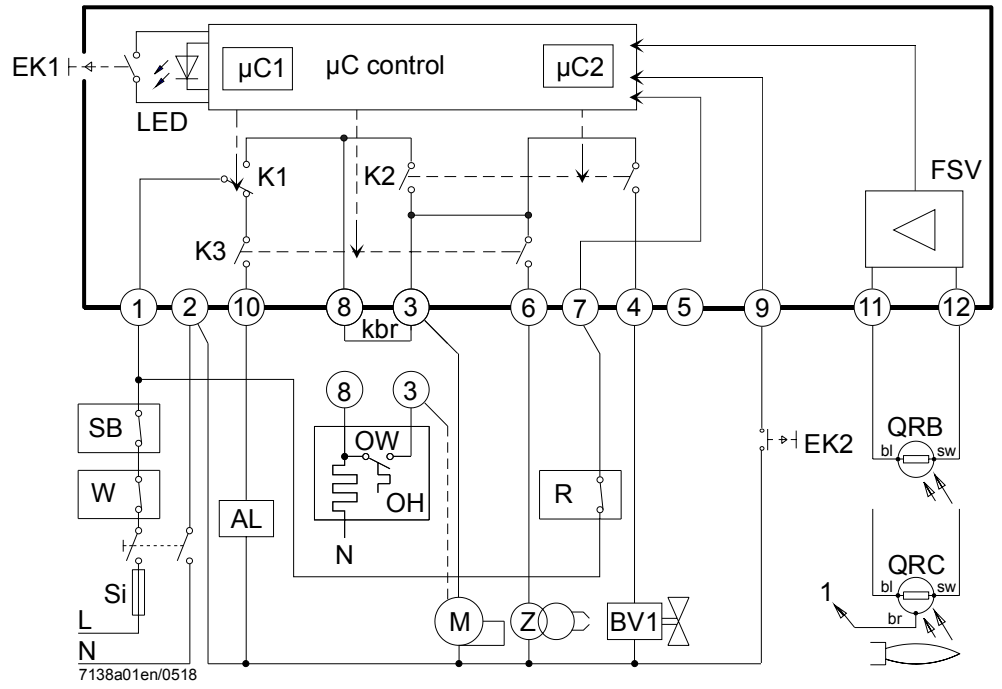

Connection diagram and internal diagram

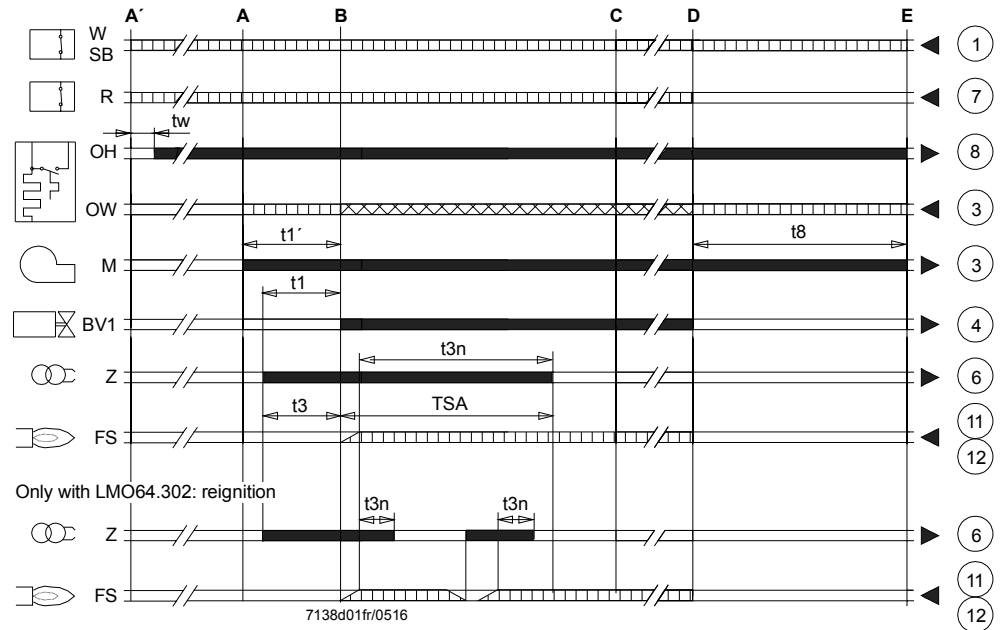

Control sequence



Legend

AL	Alarm device
BVx	Fuel valve
EK1	Lockout reset button
EK2	Remote lockout reset button
FS	Flame signal
FSV	Flame signal amplifier
Kx	Contacts of control relay
kbr	Cable link (required only when oil preheater is not used)
LED	3-color signal lamps
M	Burner motor
OW	Release contact of oil preheater
OH	Oil preheater
QRB1	Photo resistive detector
QRB3	Photo resistive detector
QRB4	Yellow flame detector
QRC	Blue-flame detector
	bl = blue, br = brown, sw = black
R	Control thermostat or pressurestat
SB	Safety limit thermostat
Si	External primary fuse
W	Limit thermostat or pressure switch
Z	Ignition transformer
TSA	Ignition safety time
tw	Waiting time
t1	Prepurge time
t1'	Purge time
t3	Preignition time
t3n	Postignition time
t8	Postpurge time
A'	Beginning of startup sequence with burners using «OH»
A	Beginning of startup sequence with burners using no «OH»
B	Time of flame establishment
C	Operating position
D	Controlled shutdown by «R»
E	End of startup sequence
	Control signals
	Required input signals
	Permissible input signals
	
μC1	Mikrocontroller 1
μC2	Mikrocontroller 2

Dimensions

Dimensions in mm

LMO64



Plug-in base AGK11.6

